

✓ Achievable surface roughness $Rz < 1 \mu\text{m}$ / $Ra < 0,16 \mu\text{m}$

Fillets, Radii, contours, and spherical surface

Application

- Tools burnish contours, radii, cylindrical, spherical, tapered and flat surfaces.
- Provide time saving through a high processing power and speed.
- Provide surface hardness and at low rate calibration (measurement accuracy).
- Easy to change the spare parts.
- Short process time. No sawdust.
- Needs min. lubrication (oil or emulsion),

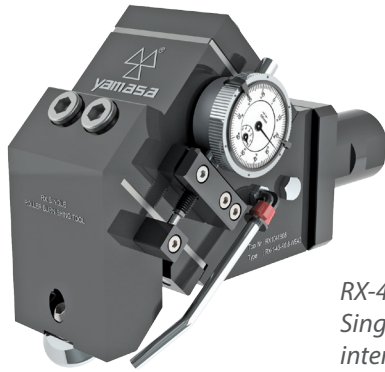

RX-45-1-R2,5-ZS40
Single roller burnishing tool
internal coolant

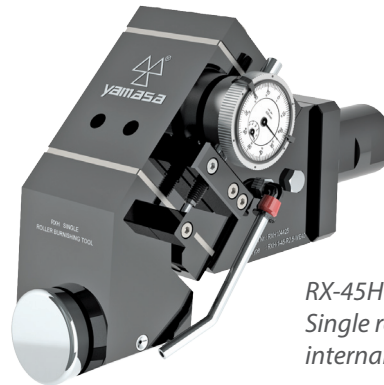

RX-45H-1-R2,5-ZS40
Single roller burnishing tool
internal coolant

RX-45 Processing properties and parameters

Processable surfaces	Cylindrical and radii up to the face
Machinable materials	low and midlevel strength
Circumferential speed	max. 300 m/min.
Feed rate	max. 1 mm/rev.
Rolling share	up to 0,03 mm
Rolling force	max. 4000 Newton
Pre-machining roughness	$Rz = 5 - 30 \mu\text{m}$
Coolant	Oil or emulsion

RX-45H Processing properties and parameters

Processable surfaces	Cylindrical and radii up to 75°
Machinable materials	High strength
Circumferential speed	max. 300 m/min.
Feed rate	max. 1 mm/rev.
Rolling share	up to 0,03 mm
Rolling force	max. 10000 Newton
Pre-machining roughness	$Rz = 5 - 30 \mu\text{m}$
Coolant	Oil or emulsion

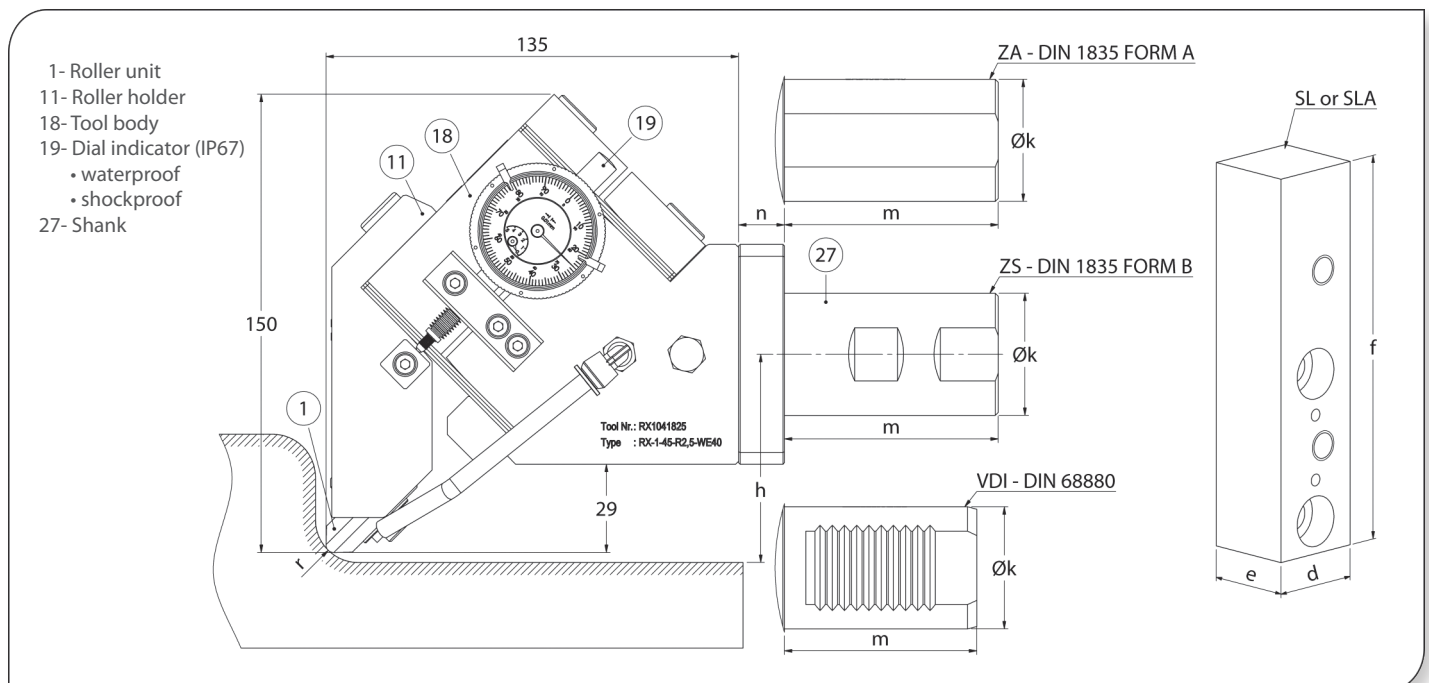

RX tools are available for deep rollig applications. Please ask.

Technical features and advantages

- Burnishing different sizes with same tool.
- Used on CNC, universal and lathe machines with copy systems.
- Tool design allows either right or left hand operation.
- Don't require settings and when the tool is fixed to the machine, it is ready to use.
- Roller burnishing force is adjustable, so it is possible to achieve high quality and standard roughness values.
- Spring system apply rolling force consistently. So it provides high quality and standard work flow.
- Shoulders and other edges is possible up to the end.
- Burnishing all kinds of metallic materials up to the tensile strength of $1400\text{N}/\text{mm}^2$ and to the hardness 42-45 HRC.

Single Roller Burnishing Tools

Tool structure

- Tools consist of a connecting shank, precision body, roller head and a dial indicator which shows rolling force.
- Dial indicator is IP67 protected and has a waterproof-shockproof structure.
- Square, cylindrical or VDI shanks are available.

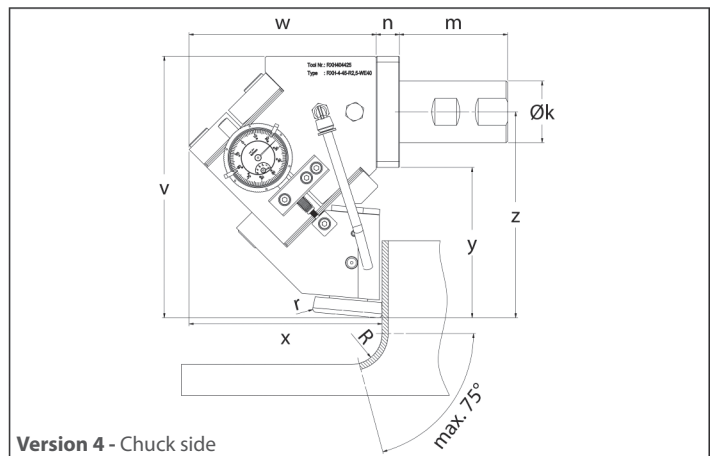
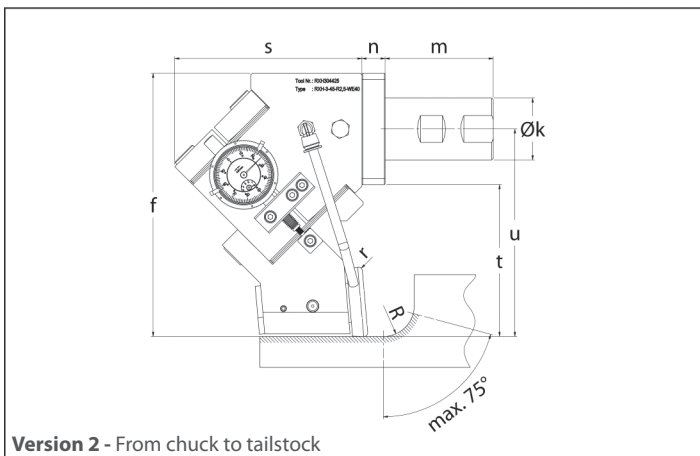
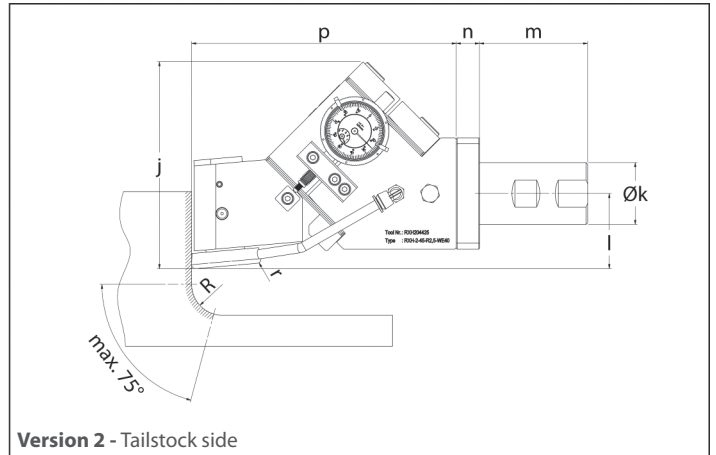
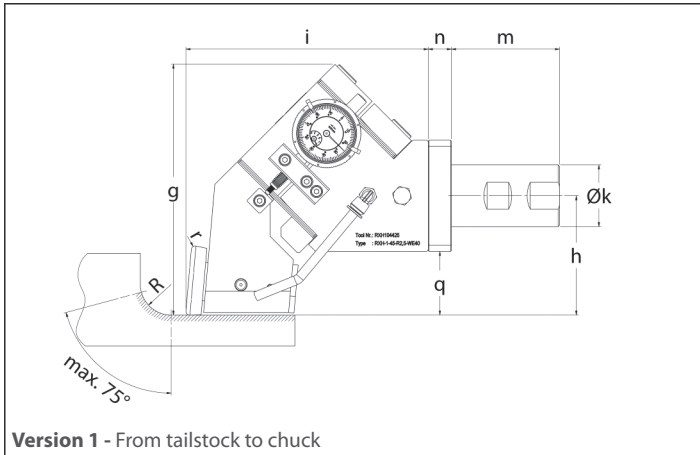

Dimensions

Tool type	Design	Shank	Height		Version 1		Version 2		Version 3		Version 4					n						
			a	b*	g	h	i	q	j	l	p	f	s	t	u		v	w	x	z	y	
RX	45 45H	all types	56	72	163	77	157	41	134	49	172	171	122	98	134	170	122	125	133	97	15	
		VDI40		83																		
		VDI50		100																		
		VDI60		123			165				177		129									

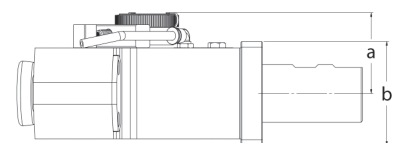

There is not "n" size at square shank tools.

Product selection

Tool selection (complete)										Spare roller unit		
Tool type	Design	Version	Roller radii (R*)	Shank					Tool type	Design	Roller radii (R*)	
				VDI	Cylindrical		Square					
				DIN69880	DIN1835 A	DIN1835 B	SL	SLA				
				(Øk x m)	(Øk x m)	(Øk x m)	(d x e x f)	(d x e x f)				
RX	45	1	0,8	VDI30(Ø30x55)	ZA32(Ø32x60)	ZS32(Ø32x60)			RX	45	0,8	
			1,2	VDI40(Ø40x63)	ZA40(Ø40x70)	ZS40(Ø40x70)	SL25(25x30x130)	SLA25(25x60x130)			1,2	
			1,6	VDI50(Ø50x78)	ZA50(Ø50x80)	ZS50(Ø50x80)	SL32(32x30x130)	SLA32(32x60x130)			1,6	
			2,5	VDI60(Ø60x94)	ZA63(Ø63x90)	ZS63(Ø63x90)					2,5	
	45H	1 2 3 4	4,0								4,0	
			6,0								6,0	

* Roller Radii max. R4,0 is possible for RX-45 type. All dimensions in mm.

How to order | Order samples

RX-45H-1-R2,5-VDI40 Single roller burnishing tool	RX-45H-R2,5 Roller unit
---	-------------------------

You can create order codes of the tool and spare parts by looking at the product selection table. For this, please rank the requested product features side by side.

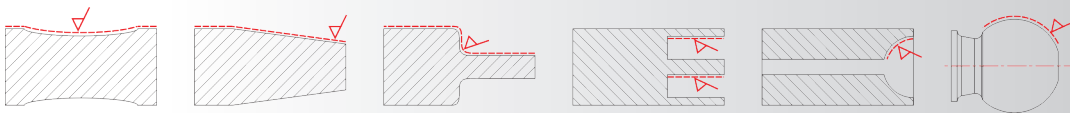

Spherical surfaces, contours, radii, fillets and groove flanks

✓ Achievable surface roughness $Rz < 1 \mu\text{m}$ / $Ra < 0,16 \mu\text{m}$

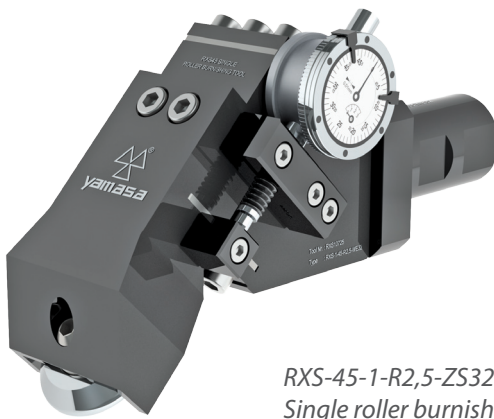

RXS-45-1-R2,5-ZS32
Single roller burnishing tool

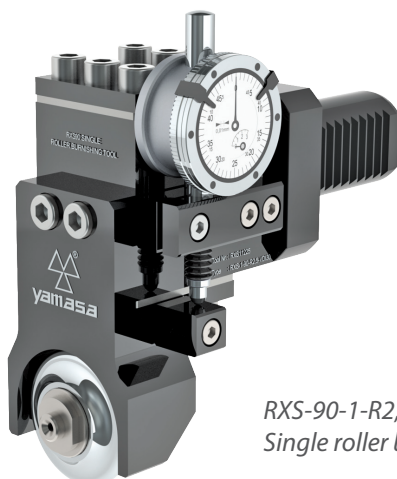
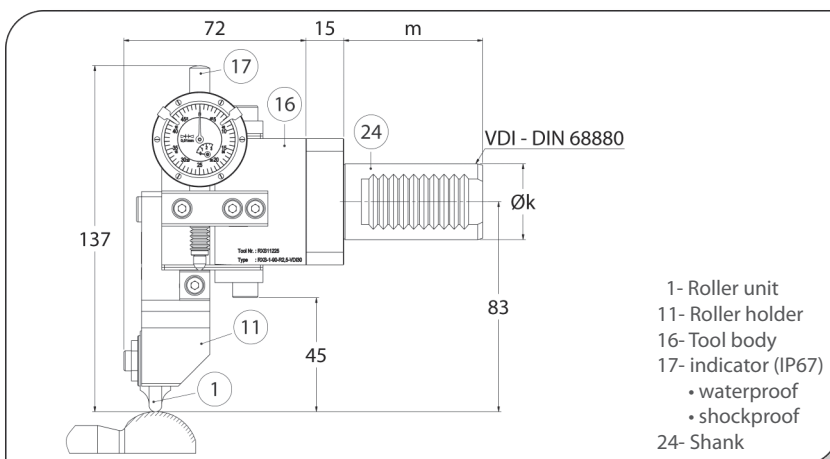
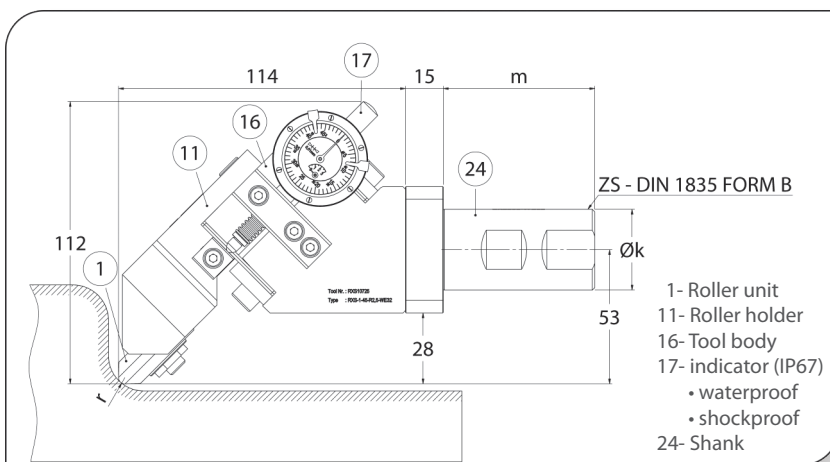

RXS-90-1-R2,5-VDI30
Single roller burnishing tool

RXS-45 Processing properties and parameters

Processable surfaces	Cylindrical and radii up to the plane face
Machinable materials	low and midlevel strength
Circumferential speed	max. 300 m/min.
Feed rate	max. 0,8 mm/rev.
Rolling share	up to 0,02 mm
Rolling force	max. 4000 Newton
Pre-machining roughness	$Rz = 5 - 20 \mu\text{m}$
Coolant	Oil or emulsion

Application

- Tools burnish spherical surfaces, contours, cylindrical surfaces with connecting radius up to the flat surface, groove flanks, tapered and flat surfaces.
- Process is done in one pass after pre-machining.
- Provide surface hardness and at low rate calibration (measurement accuracy).

Technical features and advantages

- Burnishing different sizes with same tool.
- Used on CNC and Universal lathe machines.
- Tool design allows either right or left hand operation.
- Don't require settings and when the tool is fixed to the machine, it is ready to use.
- Roller burnishing force is adjustable, so it is possible to achieve high quality and standard roughness values.
- Spring system apply rolling force consistently. So it provides high quality and standard work flow.
- Shoulders and other edges is possible up to the end.
- Burnishing all kinds of metallic materials up to the tensile strength of $1400\text{N}/\text{mm}^2$ and to the hardness 45 HRC.
- Easy to change the spare parts.
- Short process time.
- Needs min. lubrication (oil or emulsion).
- No sawdust.

RXS-90 Processing properties and parameters

Processable surfaces	Spherical surface and contours
Machinable materials	low and midlevel strength
Circumferential speed	max. 300 m/min.
Feed rate	max. 0,8 mm/rev.
Rolling share	Up to 0,02 mm
Rolling force	max. 4000 Newton
Pre-machining roughness	$Rz = 5 - 20 \mu\text{m}$
Coolant	Oil or emulsion

Single Roller Burnishing Tools

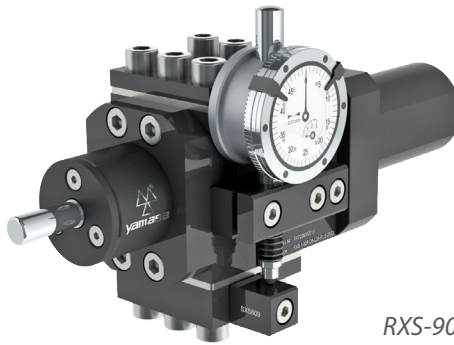

RXS-90P-1-8x20-ZA32
Single roller burnishing tool

RXS-90P Processing properties and parameters

Processable surfaces	Spherical holes, groove flanks, circular ring areas
Machinable materials	low and midlevel strength
Circumferential speed	max. 150 m/min.
Feed rate	max. 0,4 mm/rev.
Rolling share	up to 0,02 mm
Rolling force	max. 4000 Newton
Pre-machining roughness	Rz = 5 - 20 µm
Coolant	Oil or emulsion

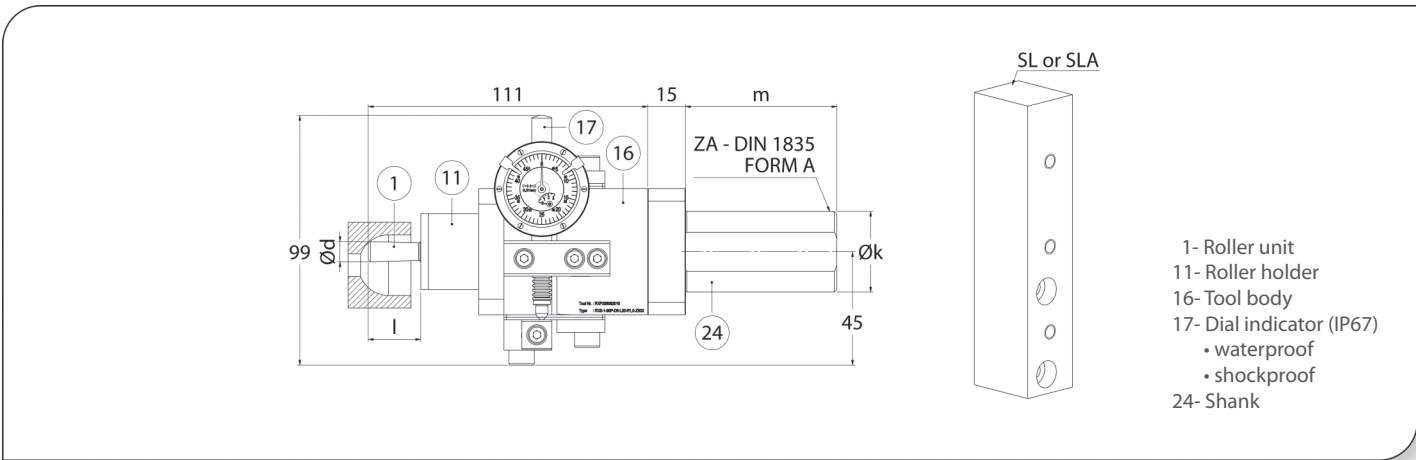

- 1- Roller unit
- 11- Roller holder
- 16- Tool body
- 17- Dial indicator (IP67)
 - waterproof
 - shockproof
- 24- Shank

Tool structure

- Tools consist of a connecting shank, precision body, roller head and a dial indicator which shows rolling force.
- Dial indicator is IP67 protected, has a waterproof-shockproof structure.
- Square, cylindrical or VDI shanks are available.

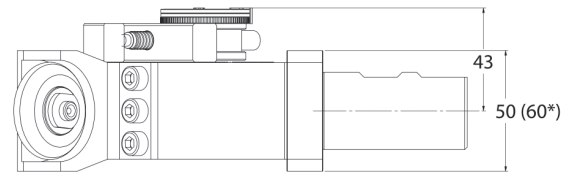

*60: for the tools with Ø40 mm VDI and cylindrical shank.

Product selection

Tool type	Design	Version	Roller radii (R*)	Tool selection (complete)					Spare roller unit		
				Shank					Tool type	Design	Roller radii (R*)
				VDI	Cylindrical		Square				
DIN69880 (Øk x m)	DIN1835 A (Øk x m)	DIN1835 B (Øk x m)	SL (d x e x f)	SLA (d x e x f)	Tool type	Design	Roller radii (R*)				
RXS	45	1	0,8	VDI20(Ø20x40)	ZA20(Ø20x50)	ZS20(Ø20x50)	SL16(16x30x120)	SLA16(16x60x120)	RXS	45	0,8
			1,2								1,2
			1,6								1,6
	90		2,5	VDI25(Ø25x48)	ZA25(Ø25x56)	ZS25(Ø25x56)	SL20(20x30x120)	SLA20(20x60x120)		2,5	
			4,0							4,0	
			(Ødxl)							(Ødxl)	
	90P		08x20	VDI40(Ø40x63)	ZA40(Ø40x70)	ZS40(Ø40x70)	SL32(32x30x120)	SLA32(32x60x120)		08x20	
			11x30							11x30	
			(Ødxl)							(Ødxl)	

All dimensions in mm.

How to order | Order samples

RXS-45-1-R2,5-ZS32 Single roller burnishing tool	RXS-45-R2,5 Roller unit
RXS-90-1-R2,5-VDI30 Single roller burnishing tool	RXS-90-R2,5 Roller unit
RXS-90P-1-8x20-ZA32 Single roller burnishing tool	RXS-90P-8x20 Roller unit

You can create order codes of the tool and spare parts by looking at the product selection table. For this, please rank the requested product features side by side.