



SLU | SLUA

BASIC LINE

from the market leader in Steady Rests

ECONOMIC CLAMPING

Best Price - Top Quality

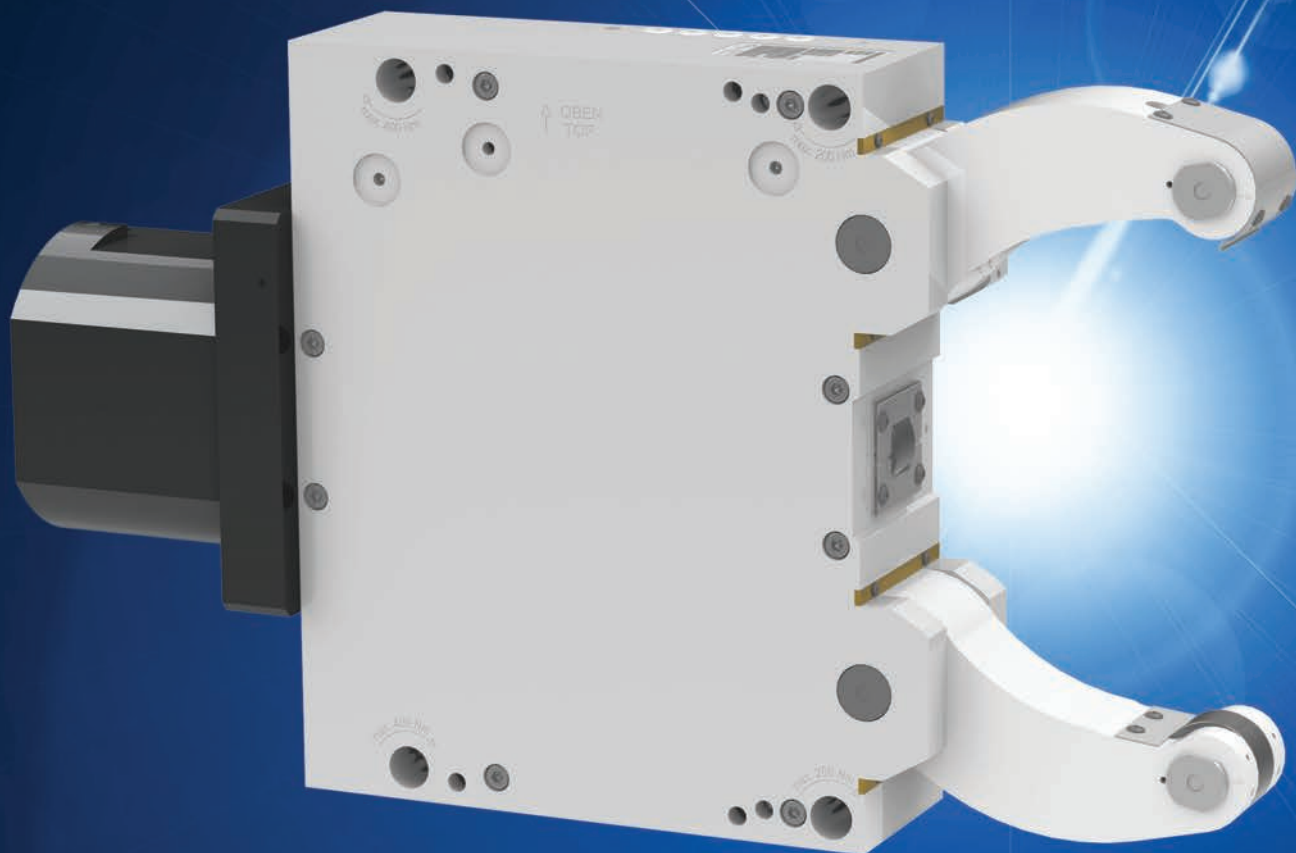

SLU

Steady Rest
Basic Line

SLUA

Steady Rest
Basic Line

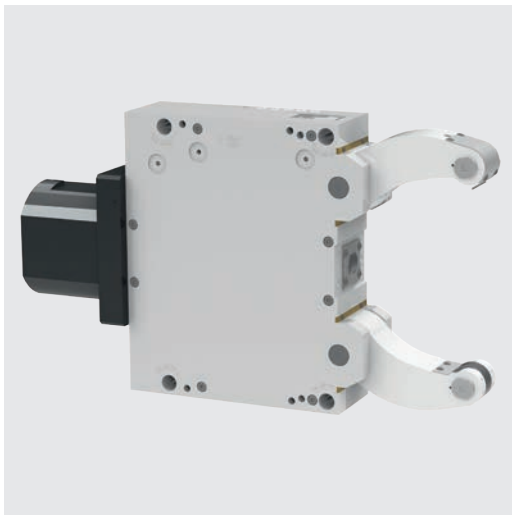

Application/customer benefits

- Basic Line Series - Economic Clamping | Best Price - Top Quality!
- Large clamping range
- Additional pivoting upper arm for automatic vertical loading (SLUA)
- Fixed or travelling application

Technical features

- Manual lubrication (M) or central lubrication oil (Z)
- Swarf guard
- Safety valve
- Stroke control (without proximity switch)

Standard equipment

Steady Rest SLU/SLUA Basic Line including 1 set of SMW-AUTOBLOK cylindrical rollers

Ordering example

SLU-M 2 Id.No. 025805

Fixed or travelling application

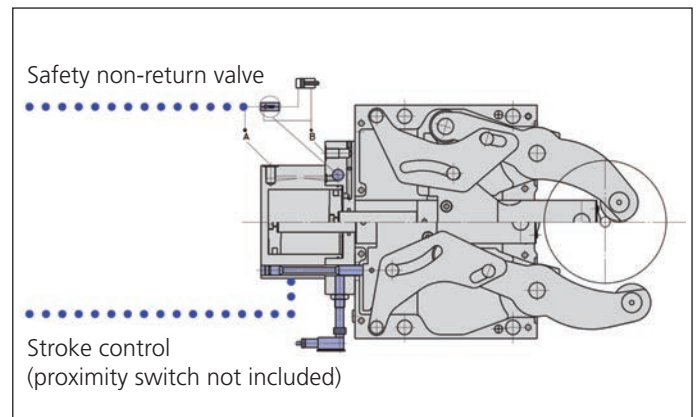
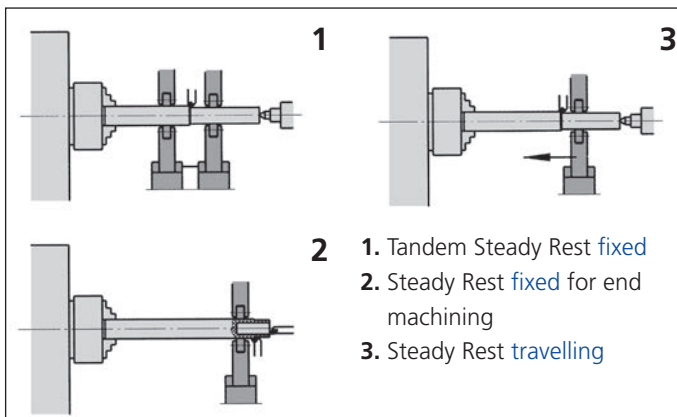

SLU / SLUA

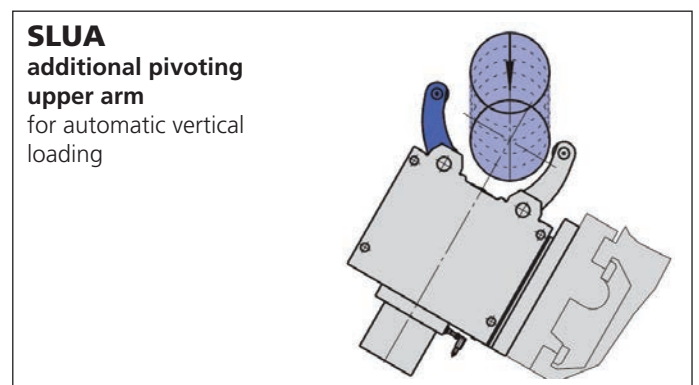
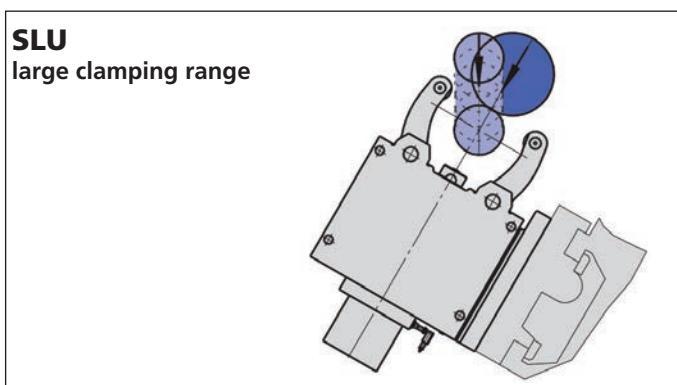

- Large Clamping Range
- Monitoring of position Steady Rest open and closed
- Hardened arms

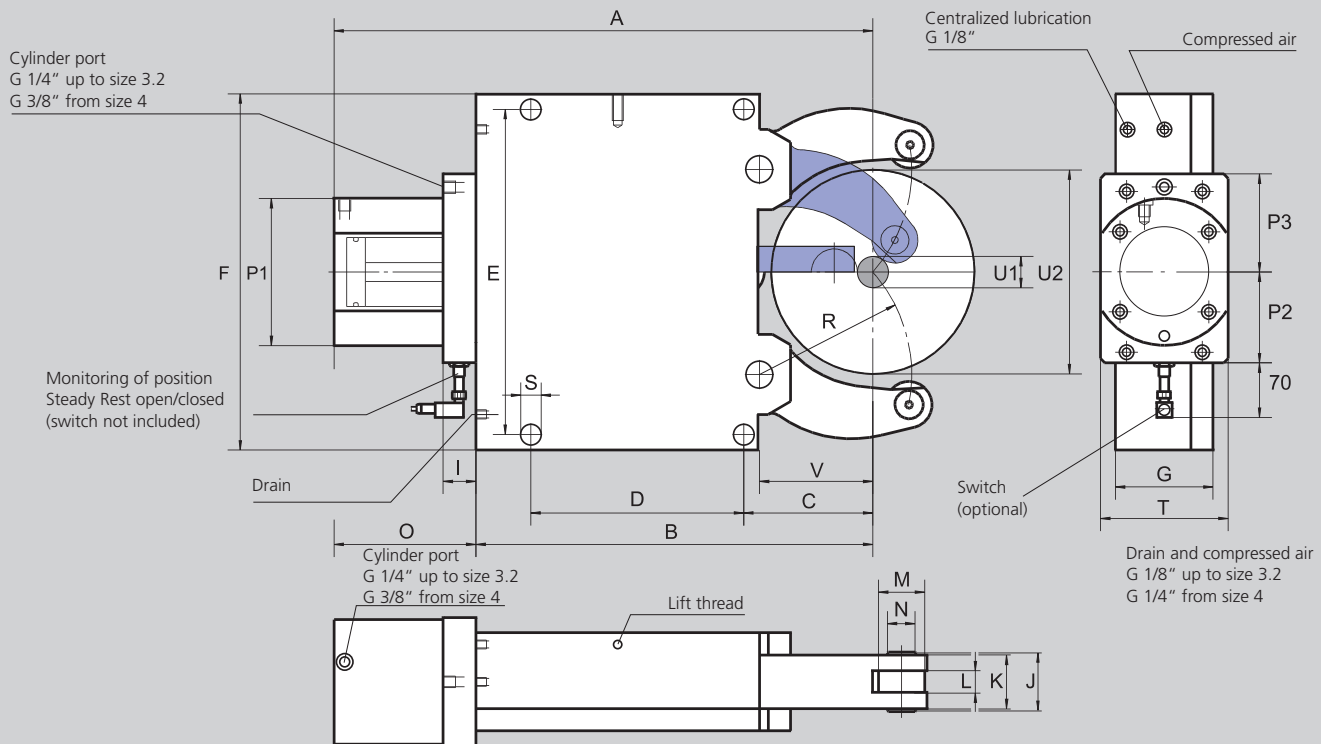

Subject to technical changes.
For more detailed information please ask for customer drawing.

SMW-AUTOBLOK Type Size	SLU 1	SLU 2	SLU 3	SLU 3.1	SLU 3.2	SLU 4	SLU 5	SLU 5.1	SLU 6
Centering range without chip guard	4	8	12	20	50	30	45	85	125
Max. axial clearing dia.	64	101	152	165	200	245	310	350	460
Centering range with chip guard 3-piece	11	16	16	20	50	30	45	85	125
	64	101	152	165	200	245	310	350	460
	207	279.5	429	437	455	608	697.5	717.5	944.5
	137	195	312	320	335	448	510	530	709
	51	70	115	123	138	146	178	198	215
	64	85	135	135	135	240	270	270	330
	118	170	262	262	262	365	400	400	610/640
	132	190	290	290	290	400	440	440	680
	55	70	85	85	85	110	145	145	145
	33	33	37	37	37	37	37	37	37
	26	42	52	52	52	67	83	83	83
	20	35	45	45	45	60	75	75	75
	12	19	25	25	25	25	29	29	29
Roller width	19	35	47	47	47	52	62	62	80
Roller diameter	6	21	25	25	25	32	36	36	42
Collar diameter	70	84.5	117	117	120	160	187.5	187.5	235.5
	84	102	137	137	137	165	165	165	190
	66	72	90	90	90	102	102	102	115
	66	75	100	100	100	110	110	110	130
	50.5	74	119	124	139	172	209	229	290
	11	14	18	18	18	23	23	23	27
	70	70	100	100	100	144	144	144	158
	37	52	85	93	103	128	160	180	175
Piston area	cm ²	7	19.6	50	50	50	78	78	132
Operation pressure min./max.	bar	6/50	8/70	8/60	8/60	8/60	8/60	8/80	8/70
Max. clamping force/roller	daN	100	450	1000	1000	1000	1500	2000	3000
Centering accuracy within the whole range	mm	0.02	0.02	0.04	0.04	0.04	0.05	0.06	0.06
Repeatability accuracy	mm	0.005	0.005	0.007	0.007	0.007	0.007	0.01	0.01
Max. roller surface speed	m/min	800	800	725	725	725	715	600	560
Weight approx.	kg	6	14	39	40	43	92	152	420

- Additional pivoting upper arm
- Monitoring of position Steady Rest open and closed
- Hardened arms

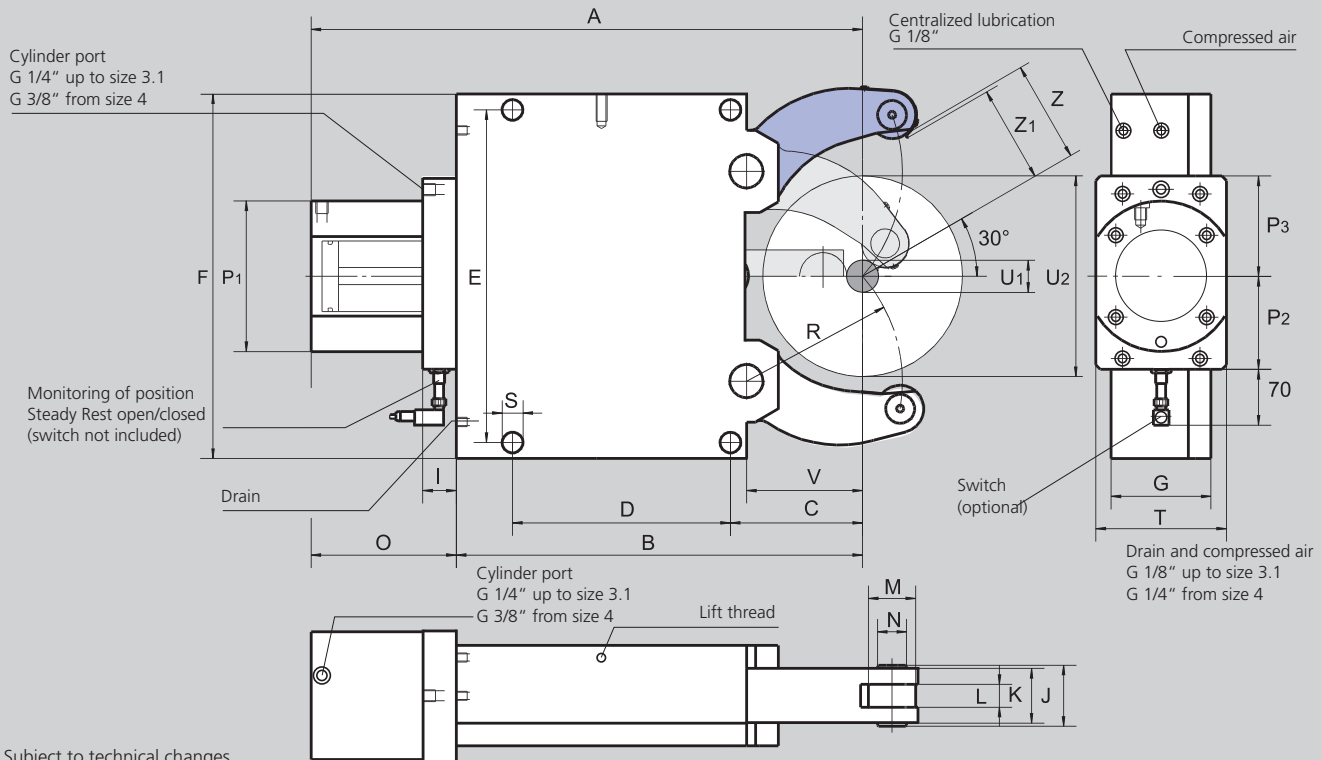

Subject to technical changes.
For more detailed information please ask for customer drawing.

SMW-AUTOBLOK Type Size		SLUA 1	SLUA 2	SLUA 3	SLUA 3.1	SLUA 4	SLUA 5	SLUA 6
Centering range without chip guard	U1	4	8	12	20	30	45	125
	U2	52	80	130	150	220	268	460**
Max. axial clearing dia.	U1	11	16	22	22	30	50	160
Centering range with chip guard 3-piece	U2	52	80	150	150	220	268	460
	Z	26.5	41	66	76	111	135	230**
	Z1	24	34	62	72	106.5	130	225**
	A	207	279.5	429	437	608	697.5	944.5
	B	137	195	312	320	448	510	709
	C	51	70	115	123	146	178	215
	D	64	85	135	135	240	270	330
	E	118	170	262	262	365	400	610/640
	F	132	190	290	290	400	440	680
	G	55	70	85	85	110	145	145
	I	33	33	37	37	37	37	37
	J	26	42	52	52	67	83	83
	K	20	35	45	45	60	75	75
	L	12	19	25	25	25	29	29
Roller width	M	19	35	47	47	52	62	80
Roller diameter	N	6	21	25	25	32	36	42
Collar diameter	O	70	84.5	117	117	160	187.5	235.5
	P1	84	102	137	137	165	165	190
	P2	66	72	90	90	102	102	115
	P3	66	75	100	100	110	110	130
	R	50.5	74	119	124	172	209	290
	S	11	14	18	18	23	23	27
	T	70	70	100	100	144	144	158
	V	37	52	85	93	128	160	175
Piston area	cm ²	7	19.6	50	50	78	78	132
Operation pressure min./max.	bar	6/50	8/70	8/60	8/60	8/60	8/80	8/70
Max. clamping force/roller	daN	100	450	1000	1000	1500	2000	3000
Centering accuracy within the whole range	mm	0.02	0.02	0.04	0.04	0.05	0.06	0.06
Repeatability accuracy	mm	0.005	0.005	0.007	0.007	0.007	0.01	0.01
Max. roller surface speed	m/min	800	800	725	725	715	600	560
Weight approx.	kg	6	14	39	40	92	152	420

** SLUA 6: loading diameter U2=460 only under 19° installation

SLUSteady Rest
Basic Line**SLUA**Steady Rest
Basic Line

■ Ordering review

Steady Rest SLU Basic Line (including 1 set of SMW-AUTOBLOK cylindrical rollers)







Steady Rest size		1	2	3	3.1	3.2	4	5	5.1	6
SLU-M manual lubrication	Id. No.	025804	025805	025806	025807	120689	122186	122416	122469	026586
SLU-Z central lubrication	Id. No.	025457	025402	025401	025406	120690	122185	122415	122468	026492

Steady Rest SLUA Basic Line (including 1 set of SMW-AUTOBLOK cylindrical rollers)

Steady Rest size		1	2	3	3.1	4	5	6
SLUA-M manual lubrication	Id. No.	024458	024459	024460	024461	122546	024463	026591
SLUA-Z central lubrication	Id. No.	024482	024483	024673	024674	122545	024485	026593

Accessories and wearing parts

◆ denotes wearing parts, recommended stock items

Steady Rest size		1	2	3	3.1	3.2	4	5	5.1	6
Compact lubrication system for oil pressure lubrication Container 2,7 l, 110 or 220 V*		088707	088707	088707	088707	088707	088707	088707	088707	088707
Excenter fine adjustment compl. at lever arm (2 pcs. per Steady Rest)		-	026120	018437	018437	018437	018444	018450	018450	026595
Inductive limit switch		087926	087926	087926	087926	087926	087926	087926	087926	087926
Swarf guard 3-pieces	 ◆	026115	026116	026117	026117	026117	026118	026119	026119	026597
Roller stripper (2-pieces) for middle piece	 ◆	029795	029796	029797	029797	029797	029798	029799	029799	029800
Rollers cylindrical design	 ◆	017869	016952	016951	016951	016951	016953	018345	018345	026594
Rollers spherical design	 ◆	016900	017658	018433	018433	018433	018443	019545	019545	-

* When placing an order please advise voltage



SMW-AUTOBLOK Spannsysteme GmbH
Postfach 1151 • D-88070 Meckenbeuren
Wiesentalstraße 28 • D-88074 Meckenbeuren
Tel.: +49 (0) 7542 - 405 - 0

Vertrieb Inland:
Fax: +49 (0) 7542 - 3886
E-mail ➤ vertrieb@smw-autoblok.de

Sales International:
Fax: +49 (0) 7542 - 405 - 181
E-mail ➤ sales@smw-autoblok.de



www.smw-autoblok.de