

Scheibenfräser aus VHM mit **18 Zähnen** für hohe Frästiefen.  
Disc milling cutter with **18 teeth** for high milling depths.

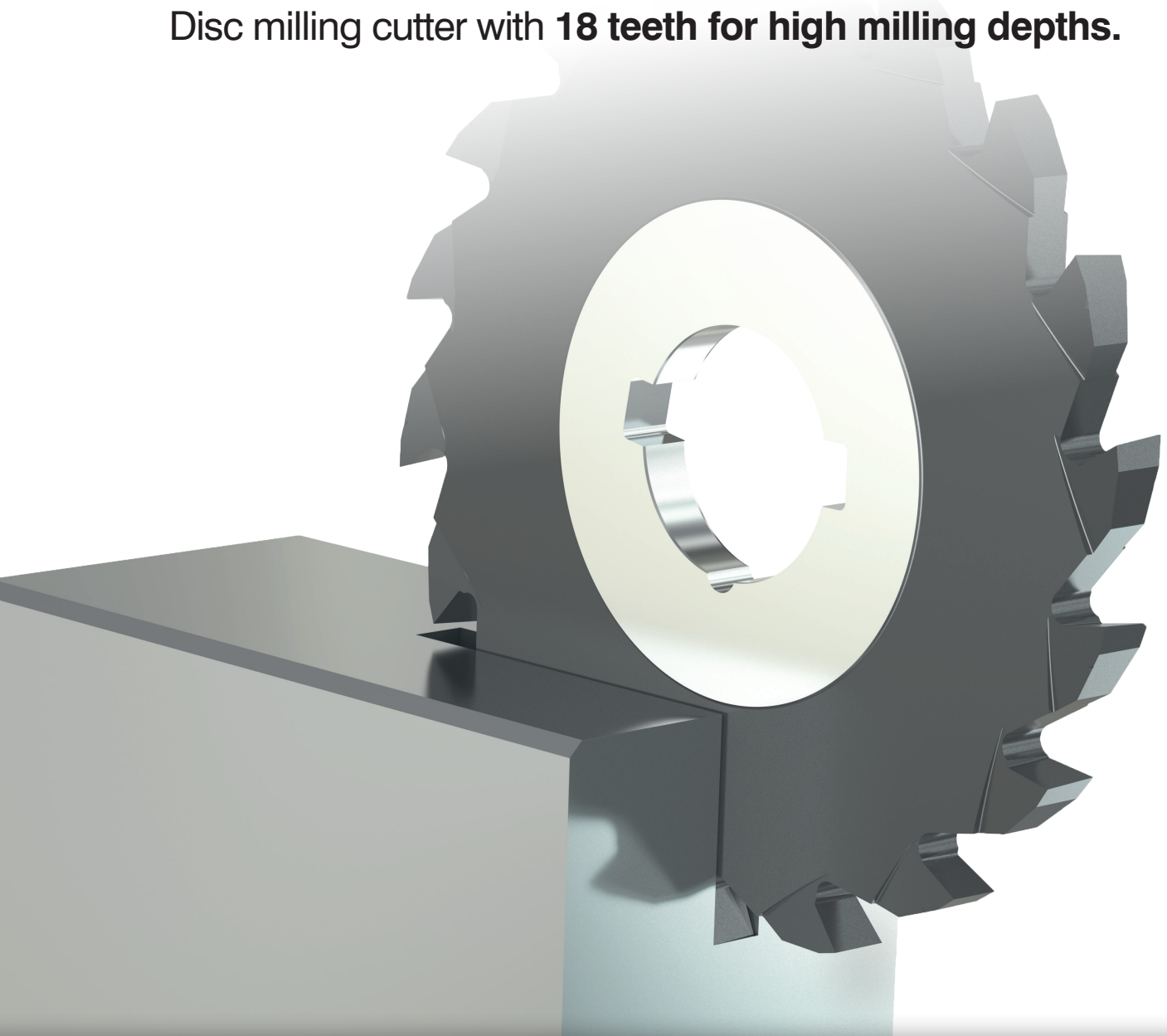

## Scheibenfräser, VHM

Hochleistungs-Scheibenfräser aus VHM für das Nutfräsen.

## Disc Milling Cutter, Solid Carbide

High performance solid carbide disc milling cutters for groove milling.

Schnittwerte (Start) // Cutting parameters (start)

f<sub>zm</sub>  
**0,06 mm**

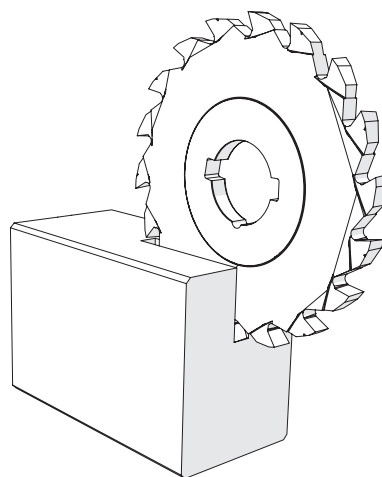
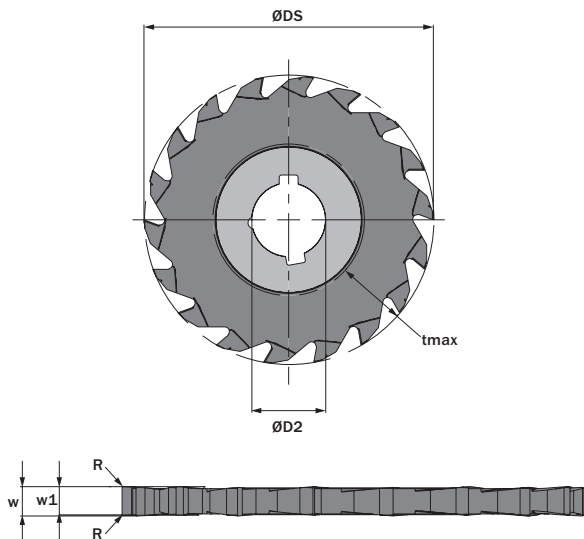

ØDS	w	R	Artikelnummer Part number	Webcode www.simtek.com/webcode	Unsere erste Wahl Our first choice	ØD2	tmax	Anzahl Schneiden Number of cutting edges	
mm	mm	mm			P K M N S	mm	mm		
63,0	2,0	0,2	<b>Q63.0200.020 GY</b>	BCVP	X700 X500	16,0	15,0	18	new
63,0	2,5	0,2	<b>Q63.0250.020 GY</b>	BCVS	X700 X500	16,0	15,0	18	new
63,0	3,0	0,2	<b>Q63.0300.020 GY</b>	BCVU	X700 X500	16,0	15,0	18	new
63,0	4,0	0,2	<b>Q63.0400.020 GY</b>	BCVY	X700 X500	16,0	15,0	18	new
63,0	5,0	0,2	<b>Q63.0500.020 GY</b>	BCV0	X700 X500	16,0	15,0	18	new
63,0	6,0	0,2	<b>Q63.0600.020 GY</b>	BCV2	X700 X500	16,0	15,0	18	new
63,0	8,0	0,2	<b>Q63.0800.020 GY</b>	BCV4	X700 X500	16,0	15,0	18	new
63,0	10,0	0,2	<b>Q63.1000.020 GY</b>	BCV6	X700 X500	16,0	15,0	18	new

simmill AX

simmill PMX

simmill PX

simmill SX

simmill UX

simmill VX

simmill 9W4

simmill H2

simmill K2

simmill MX

simmill QX

simmill OS

Index

1

# Scheibenfräser, VHM

Hochleistungs-Scheibenfräser aus VHM für das Nutfräsen.

## Disc Milling Cutter, Solid Carbide

High performance solid carbide disc milling cutters for groove milling.

Schnittwerte (Start) // Cutting parameters (start)
f <sub>zm</sub> 0,06 mm

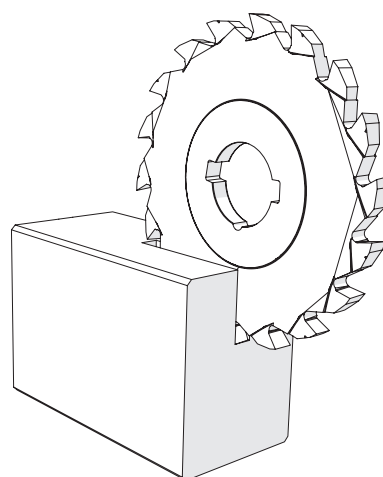
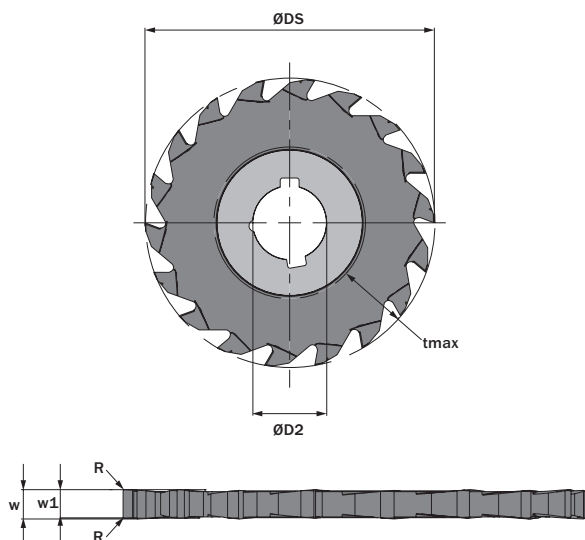

ØDS	w	R	Artikelnummer Part number	Webcode www.simtek.com/webcode	Unsere erste Wahl Our first choice	ØD2	tmax	Anzahl Schneiden Number of cutting edges	
mm	mm	mm			P K M N S	mm	mm		
63,0	2,0	-	Q63.0200.000 GY	BCZU	X700 X500	16,0	15,0	18	new
63,0	2,5	-	Q63.0250.000 GY	BCZW	X700 X500	16,0	15,0	18	new
63,0	3,0	-	Q63.0300.000 GY	BCZY	X700 X500	16,0	15,0	18	new
63,0	4,0	-	Q63.0400.000 GY	BCZ0	X700 X500	16,0	15,0	18	new
63,0	5,0	-	Q63.0500.000 GY	BCZ2	X700 X500	16,0	15,0	18	new
63,0	6,0	-	Q63.0600.000 GY	BCZ4	X700 X500	16,0	15,0	18	new
63,0	8,0	-	Q63.0800.000 GY	BCZ6	X700 X500	16,0	15,0	18	new
63,0	10,0	-	Q63.1000.000 GY	BCZ8	X700 X500	16,0	15,0	18	new

simmill AX  
 simmill PMX  
 simmill PX  
 simmill SX  
 simmill UX  
 simmill VX  
 simmill 9W4  
 simmill H2  
 simmill K2  
 simmill MX  
 simmill QX  
 simmill OS  
 Index