

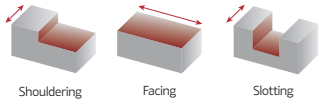



# High performance on tangential shoulder milling



**TGPLUS** NEW  
90090 | 90190 | 90390

PHS  
NEW  
GRADE



INSERT SIZE <b>09</b> LNXT 0904...	INSERT SIZE <b>13</b> LNXT 1306...	INSERT SIZE <b>15</b> LNXT 1506...
		
NEW		

SINCE 1916

## MAIN FEATURES

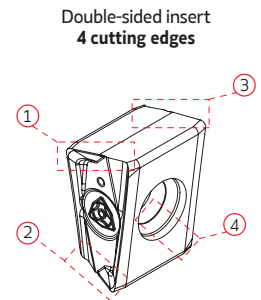
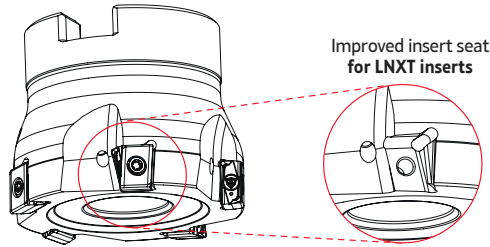
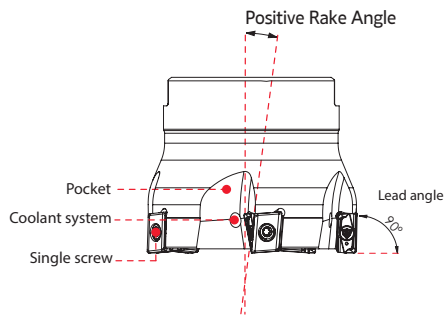

### Positive Rake Angle

- For a smooth cutting;
- For low cutting forces;

### Single screw

- Strong clamping system;

### Pocket

- Better chip evacuation due to a wide pocket;

### Coolant system

- Improvement of chip control and evacuation;
- Tool life improvement due to reduced cutting temperature;

### True 90° wall

- 90° allows multi applications;
- Excellent for tangential shoulder milling;

### Insert Width

- High thickness allows a stronger insert;

### Relief angle

- Reduce the cutting load;
- Low cutting forces;

### Double-sided insert

- 4 cutting edges;
- Negative insert has a strong edge;

## COMPARATIVE CHAT | Gráfico comparativo | Gráfico comparativo

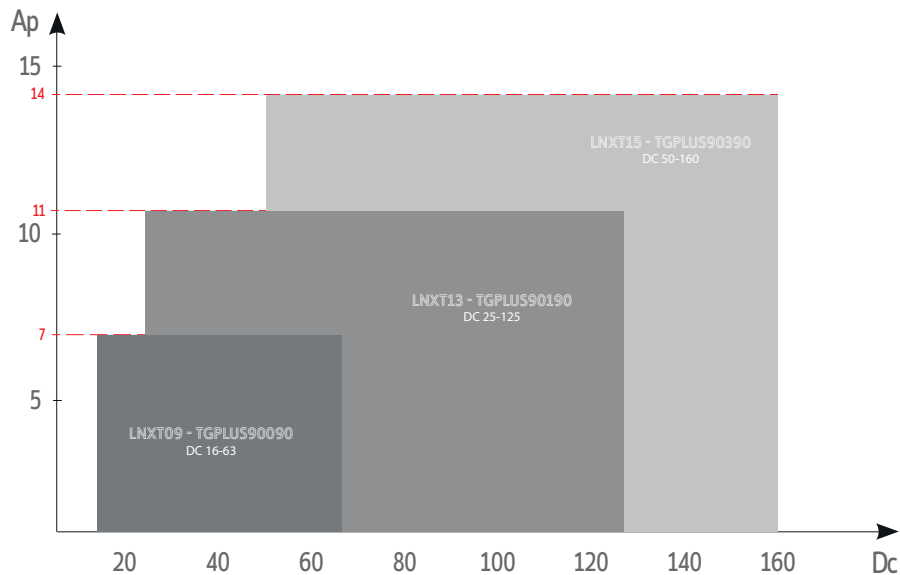

# TGPLUS 90090

LNXT-MP

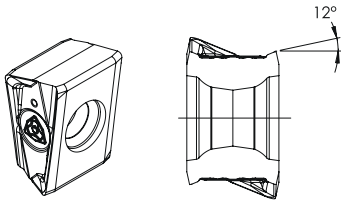

INSERT SIZE  
**09** LNXT  
0904...

LNXT-MP

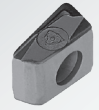

## CHIP-BREAKER | Quebra aparas | Rompevirutas

Chip Breaker	Features   Características   Características
Geometry <b>MP</b> - General machining	Chip-breaker with a reinforced chamfer for general applications on steel and cast iron.

# TGPLUS 90190

LNXT-MP

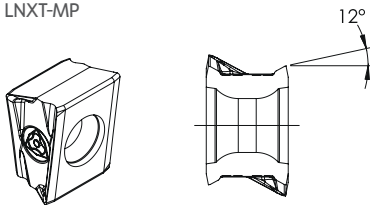

INSERT SIZE  
**13** LNXT  
1306...

LNXT-MP



## CHIP-BREAKER | Quebra aparas | Rompevirutas

Chip Breaker	Features   Características   Características
Geometry <b>MP</b> - General machining	Chip-breaker with a reinforced chamfer for general applications on steel and cast iron.

# TGPLUS 90390

LNXT-MP

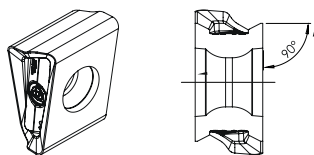

LNXT-HP

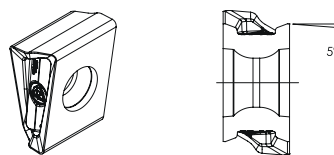

INSERT SIZE  
**15** LNXT  
1506...

LNXT-MP

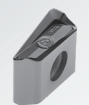

LNXT-HP

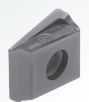

LNXT-W



LNXT-W

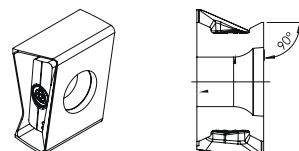

## CHIP-BREAKERS | Quebra aparas | Rompevirutas

Chip Breaker	Features   Características   Características
Geometry <b>MP</b> - General machining	Chip-breaker with a reinforced chamfer for general applications on steel and cast iron.
Geometry <b>HP</b> - Heavy machining of steels	Chip-breaker with a reinforced chamfer for Medium to heavy cutting conditions.
Geometry <b>W</b> - Wiper	Chip-breaker wiper for the best finishing solutions.

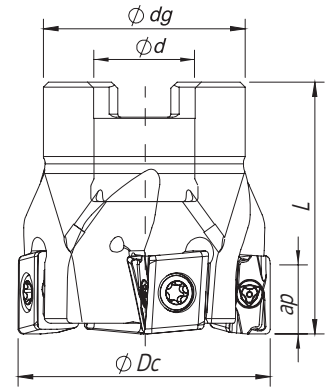

### Arbor Mounting

$K_r=90^\circ$  |  $\gamma_p=-4^\circ$

Order code Código	Reference Referência Referencia		Dimensions   Dimensões   Dimensiones (mm)				Kg	Specifications		Insert	Stock
			$\phi Dc$	$\phi d/M$	$\phi dg$	L		$A_p$ max (mm)	Arbor Type		
181144400	040A90090-04-04-016040	4	40	16	36	40	0,24	7,0	A	LNXT 0904...	
181144500	050A90090-05-04-022040	5	50	22	40	40	0,32	7,0	A	LNXT 0904...	
181144600	063A90090-07-04-022040	7	63	22	48	40	0,54	7,0	A	LNXT 0904...	
181146600	063A90090-10-04-022040	10	63	22	48	40	0,54	7,0	A	LNXT 0904...	

Stock item | Produto de stock | Itens de stock

Available under request | Disponível sobre consulta | Disponible bajo consulta

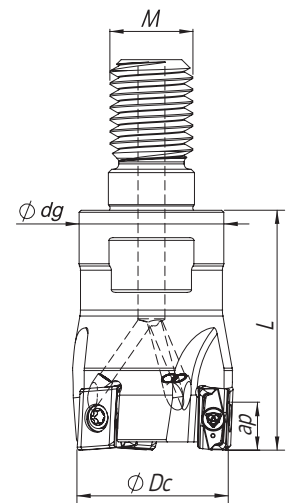

### Threaded Coupling

$K_r=90^\circ$  |  $\gamma_p=-4^\circ$

Order code Código	Reference Referência Referencia		Dimensions   Dimensões   Dimensiones (mm)				Kg	Specifications		Insert	Stock
			$\phi Dc$	$\phi d/M$	$\phi dg$	L		$A_p$ max (mm)	Arbor Type		
181144200	025R90090-03-04-M12035	3	25	12	21	35	0,10	7,0	A	LNXT 0904...	
181144300	032R90090-04-04-M16040	4	32	16	29	40	0,21	7,0	A	LNXT 0904...	

Stock item | Produto de stock | Itens de stock

Available under request | Disponível sobre consulta | Disponible bajo consulta

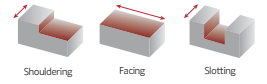

**Weldon Shank**  
 $K_r = 90^\circ$  |  $\gamma_p = -4^\circ \sim -6^\circ$

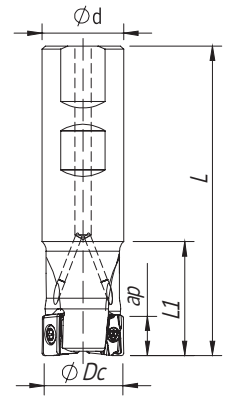

Order code Código	Reference Referência Referencia		Dimensions   Dimensões   Dimensiones (mm)				Kg	Specifications Ap max (mm)	Insert	Stock
			$\phi D_c$	$\phi d/M$	L	L1				
181109400	016W90090-02-06-016090	2	16	16	90	25	0,12	7,0	LNXT 0904...	
181109500	025W90090-03-04-025095	3	25	25	95	30	0,31	7,0	LNXT 0904...	
181144100	032W90090-04-04-032110	4	32	32	110	30	0,61	7,0	LNXT 0904...	

Stock item | Produto de stock | Itens de stock

Available under request | Disponível sobre consulta | Disponible bajo consulta



**Cylindrical Shank**  
 $K_r = 90^\circ$  |  $\gamma_p = -4^\circ$

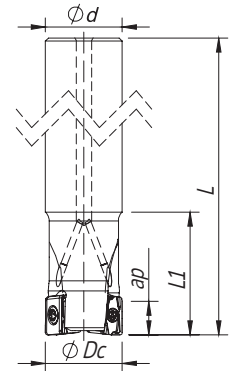

Order code Código	Reference Referência Referencia		Dimensions   Dimensões   Dimensiones (mm)				Kg	Specifications Ap max (mm)	Insert	Stock
			$\phi D_c$	$\phi d/M$	L	L1				
181158800	020E90090-02-04-020150	2	20	20	150	30	0,15	7,0	LNXT 0904...	
181148100	025E90090-03-04-025200	3	25	25	200	30	0,31	7,0	LNXT 0904...	
181148200	032E90090-04-04-032250	4	32	32	250	30	0,78	7,0	LNXT 0904...	

Stock item | Produto de stock | Itens de stock

Available under request | Disponível sobre consulta | Disponible bajo consulta

## LNXT 0904... | Inserts | Pastilhas | Plaquetas

LNXT-MP  
(PHS grade)

NEW



LNXT-MP

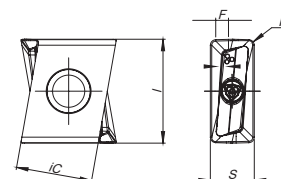

Geometry code	ISO Reference	P					M				K				N		S		H		Dimensions Dimensões Dimensiones (mm)						
		CVD		PVD			CVD		PVD		CVD		PVD		UNC	PCD	PVD	PVD	CBN								
		T9	P7	G1	G4	P3	R1	G4	P3	G6	L5	L6	G1	G4	P3	G6	10	D6	P3	G6	P7	D4					
1112225	LNXT 090404 PNER-MP	☉			☉					☉	☉	☉	☉	☉									-	4,5	9,0	0,4	-
1112226	LNXT 090408 PNER-MP	☉			☉					☉	☉	☉	☉	☉									-	4,5	9,0	0,8	-

☉ First choice | Primeira opção | 1ª opción

☼ Stock item | Produto de stock | Itens de stock

○ Available under request | Disponível sobre consulta  
Disponível bajo consulta

Insert order code = (1) Geometry Code + (2) Grade Code

## SPARE PARTS | Complementos | Repuestos

Cutter ØDc	Insert Screw	Key (Torx)	Order separately	
			Key (Torx - Nm)	Torque Value
E90090 - 25-32	P0250700	XT07	DT0709	1,2
W90090 - 16-32	P0250700	XT07	DT0709	1,2
A90090 - 40-63	P0250700	XT07	DT0709	1,2
R90090 - 25-32	P0250700	XT07	DT0709	1,2

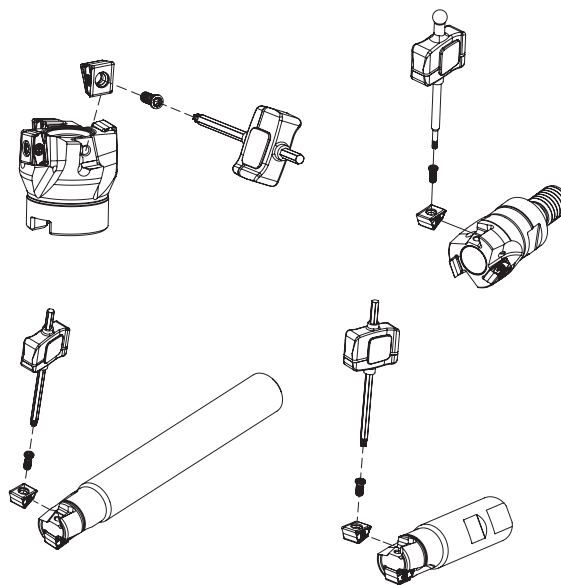

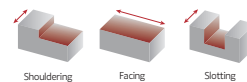

## GRADES SELECTION GUIDE | Guia para selecção de graus | Tabla para selección de calidades

ISO	PSM	Material	HB (Brinell)	Grades			
				← Wear Resistance		Toughness →	
				PH5320	PH7920	PHS740	PH7740
P	1	Unalloyed Steel	125-220		✓	✓	
	2	Low-Alloyed Steel	220-280		✓	✓	
	3	High-Alloyed Steel	280-380		✓	✓	
M	4	SS - Ferritic / Martensitic	200-330				✓
	5	SS - Austenitic	200-330				✓
	6	SS - Austenitic-ferritic (Duplex)	230-260				✓
K	7	Malleable Cast Iron	130-230	✓	✓		✓
	8	Grey Cast Iron	180-245	✓	✓		✓
	9	Nodular Cast iron	160-250	✓	✓		✓



## RECOMMENDED CUTTING CONDITIONS | Condições de corte recomendadas | Condiciones de corte recomendables

ISO	PSM	Material	HB (Brinell)	Vc (m/min)				Feed fz (mm/t)
				← Wear Resistance		Toughness →		
				PH5320	PH7920	PHS740	PH7740	LNXT 09... MP
P	1	Unalloyed Steel	125-220	-	180-250	140-170	-	0,08-0,30
	2	Low-Alloyed Steel	220-280	-	170-210	130-160	-	0,08-0,25
	3	High-Alloyed Steel	280-380	-	160-200	110-140	-	0,08-0,15
M	4	SS - Ferritic / Martensitic	200-330	-	-	-	120-180	0,08-0,25
	5	SS - Austenitic	200-330	-	-	-	100-150	0,08-0,20
	6	SS - Austenitic-ferritic (Duplex)	230-260	-	-	-	70-130	0,08-0,15
K	7	Malleable Cast Iron	130-230	180-320	170-300	-	160-270	0,08-0,30
	8	Grey Cast Iron	180-245	160-270	150-250	-	140-230	0,08-0,25
	9	Nodular Cast iron	160-250	100-230	90-210	-	90-200	0,08-0,20

(Note 1) Cutting conditions  $a_e/D_c=70\%$ .

(Note 2) It's possible to occur vibrations in certain cases. Please reduce depth of cut and / or reduce cutting conditions in following cases:

- When using long shank;
- When using long tool overhang with arbor type;
- When application has poor clamping rigidity or when using a low rigidity machine.



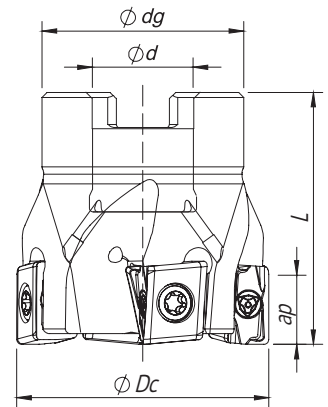
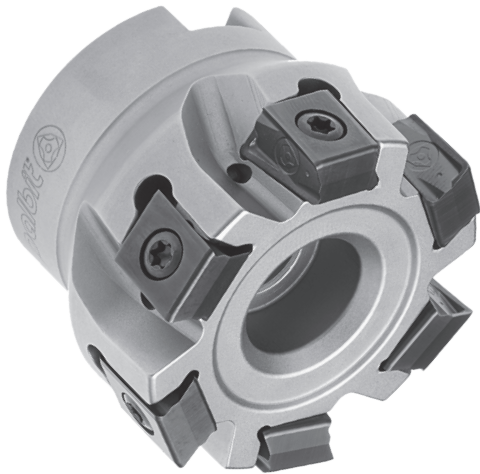

**Arbor Mounting**  
 $\kappa_r = 90^\circ$  |  $\gamma_p = -4^\circ$

Order code Código	Reference Referência Referencia		Dimensions   Dimensões   Dimensiones (mm)				Kg	Specifications		Insert	Stock
			$\phi Dc$	$\phi d/M$	$\phi dg$	L		Ap max (mm)	Arbor Type		
181118800	040A90190-04-04-016040		40	16	32	40	0,17	11	A	LNXT 1306...	
181118900	040A90190-05-04-016040		40	16	32	40	0,18	11	A	LNXT 1306...	
181111200	050A90190-05-04-022040		50	22	42	40	0,27	11	A	LNXT 1306...	
181111300	050A90190-06-04-022040		50	22	42	40	0,28	11	A	LNXT 1306...	
181119000	063A90190-06-04-022040		63	22	52	40	0,52	11	A	LNXT 1306...	
181119100	063A90190-08-04-022040		63	22	52	40	0,52	11	A	LNXT 1306...	
181119200	080A90190-07-04-027050		80	27	60	50	0,88	11	B	LNXT 1306...	
181119300	080A90190-10-04-027050		80	27	60	50	0,86	11	B	LNXT 1306...	
181119400	100A90190-09-04-032050		100	32	80	50	1,56	11	B	LNXT 1306...	
181119500	100A90190-13-04-032050		100	32	80	50	1,56	11	B	LNXT 1306...	
181119600	125A90190-11-04-040063		125	40	90	63	2,87	11	B	LNXT 1306...	
181119700	125A90190-16-04-040063		125	40	90	63	2,86	11	B	LNXT 1306...	

Stock item | Produto de stock | Itens de stock

Available under request | Disponível sobre consulta | Disponible bajo consulta

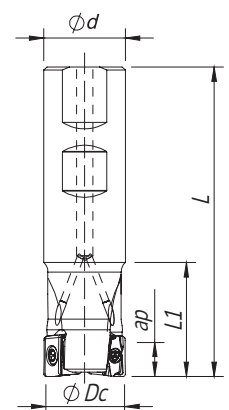

**Weldon Shank**  
 $\kappa_r = 90^\circ$  |  $\gamma_p = -4^\circ$

Order code Código	Reference Referência Referencia		Dimensions   Dimensões   Dimensiones (mm)				Kg	Specifications		Insert	Stock
			$\phi Dc$	$\phi d/M$	L	L1		Ap max (mm)	Arbor Type		
181118300	025W90190-02-04-025095		25	25	95	45	0,29	11		LNXT 1306...	
181109800	032W90190-03-04-032110		32	32	110	50	0,55	11		LNXT 1306...	
181118400	040W90190-04-04-032110		40	32	110	50	0,60	11		LNXT 1306...	

Stock item | Produto de stock | Itens de stock

Available under request | Disponível sobre consulta | Disponible bajo consulta





**Cylindrical Shank**  
 $K_r = 90^\circ$  |  $\gamma_p = -4^\circ$

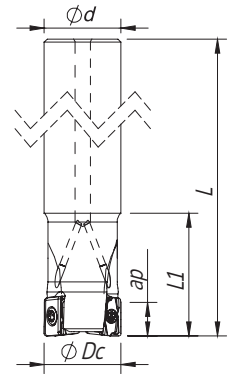

Order code Código	Reference Referência Referencia		Dimensions   Dimensões   Dimensiones (mm)				Kg	Specifications Ap max (mm)	Insert	Stock
			$\phi D_c$	$\phi d/M$	L	L1				
181118500	025E90190-02-04-025200	2	25	25	200	40	0,66	11	LNXT 1306...	
181118600	032E90190-03-04-032250	3	32	32	250	50	1,37	11	LNXT 1306...	
181118700	040E90190-04-04-032250	4	40	32	250	50	1,42	11	LNXT 1306...	

Stock item | Produto de stock | Itens de stock

Available under request | Disponível sobre consulta | Disponible bajo consulta

LNXT 1306... | Inserts | Pastilhas | Plaquetas

LNXT-MP  
(PHS grade)

NEW



LNXT-MP

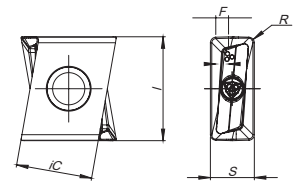

Geometry code (1)	ISO Reference	P						M				K				N		S		H	Dimensions Dimensões Dimensiones (mm)						
		CVD		PVD				CVD		PVD		CVD		PVD		UNC	PCD	PVD	PVD	CBN							
		T9	P7	G1	G4	P3	G6	R1	G4	P3	G6	L5	L6	G1	G4	P3	G6	10	D6	P3		G6	P7	D4			
1112242	LNXT 130604 PNER-MP																						9,8	6,8	13,0	0,4	0,9
NEW 1112243	LNXT 130608 PNER-MP																						9,8	6,8	13,0	0,8	0,9

First choice | Primeira opção | 1ª opción

Stock item | Produto de stock | Itens de stock

Available under request | Disponível sobre consulta | Disponible bajo consulta

Insert order code = (1) Geometry Code + (2) Grade Code

# TGPLUS 90190

## SPARE PARTS | Complementos | Repuestos

Cutter ØDc	Insert Screw	Key (Torx)	Order separately		Order separately	
			Key (Torx - Nm)	Torque Value	Screw	DIN 6368 Wrench
E90190 - 25-40	PO400900	XT15	DT1530	3,0	-	-
W90190 - 25-40	PO400900	XT15	DT1530	3,0	-	-
A90190 - 40-63	PO400900	XT15	DT1530	3,0	-	-
A90190 - 80	PO400900	XT15	DT1530	3,0	J0123510	SD6368-12
A90190 - 100	PO400900	XT15	DT1530	3,0	J0164110	SD6368-16
A90190 -125	PO400900	XT15	DT1530	3,0	J0204610	SD6368-20

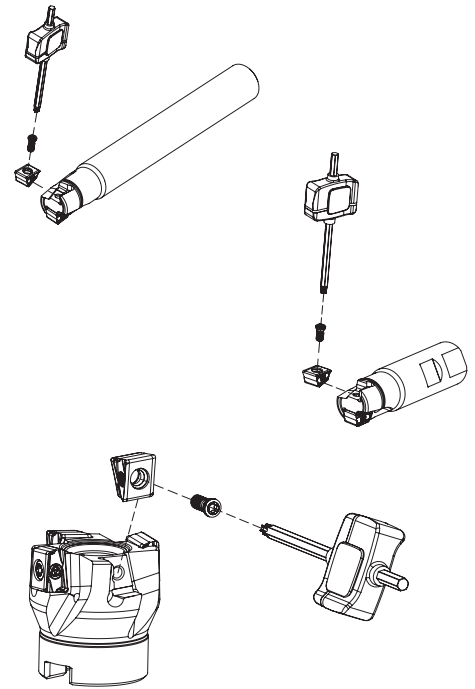

## GRADES SELECTION GUIDE | Guia para selecção de graus | Tabla para selección de calidades

ISO	PSM	Material	HB (Brinell)	Grades			
				← Wear Resistance		Toughness →	
				PH5320	PH7920	PH5740	PH7740
P	1	Unalloyed Steel	125-220	●	✓	✓	✓
	2	Low-Alloyed Steel	220-280	●	✓	✓	✓
	3	High-Alloyed Steel	280-380	●	✓	✓	✓
M	4	SS - Ferritic / Martensitic	200-330	●			✓
	5	SS - Austenitic	200-330	●			✓
	6	SS - Austenitic-ferritic (Duplex)	230-260	●			✓
K	7	Malleable Cast Iron	130-230	✓	✓		✓
	8	Grey Cast Iron	180-245	✓	✓		✓
	9	Nodular Cast iron	160-250	✓	✓		✓

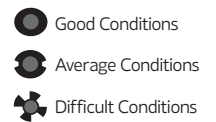

RECOMMENDED CUTTING CONDITIONS | Condições de corte recomendadas | Condiciones de corte recomendables

ISO	PSM	Material	HB (Brinell)	Vc (m/min)				Feed fz (mm/t)
				← Wear Resistance			Toughness →	
				PH5320	PH7920	PHS740	PH7740	LNXT 13... MP
P	1	Unalloyed Steel	125-220	-	180-250	140-170	140-170	0,10-0,35
	2	Low-Alloyed Steel	220-280	-	170-210	130-160	130-160	0,10-0,30
	3	High-Alloyed Steel	280-380	-	160-200	110-140	110-140	0,10-0,20
M	4	SS - Ferritic / Martensitic	200-330	-	-	-	120-180	0,10-0,30
	5	SS - Austenitic	200-330	-	-	-	100-150	0,10-0,25
	6	SS - Austenitic-ferritic (Duplex)	230-260	-	-	-	70-130	0,10-0,20
K	7	Malleable Cast Iron	130-230	180-320	170-300	-	-	0,10-0,35
	8	Grey Cast Iron	180-245	160-270	150-250	-	-	0,10-0,30
	9	Nodular Cast iron	160-250	100-230	90-210	-	-	0,10-0,25

(Note 1) Cutting conditions  $a_e/D_c=70\%$ .

(Note 2) It's possible to occur vibrations in certain cases. Please reduce depth of cut and / or reduce cutting conditions in following cases:

- When using long shank;
- When using long tool overhang with arbor type;
- When application has poor clamping rigidity or when using a low rigidity machine.

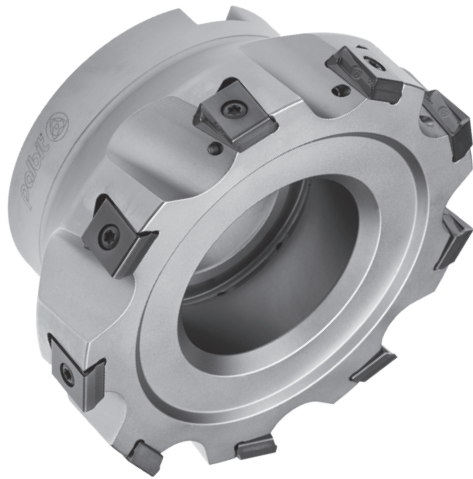

**Arbor Mounting**  
 $K_r=90^\circ$  |  $\gamma_p=-5^\circ$

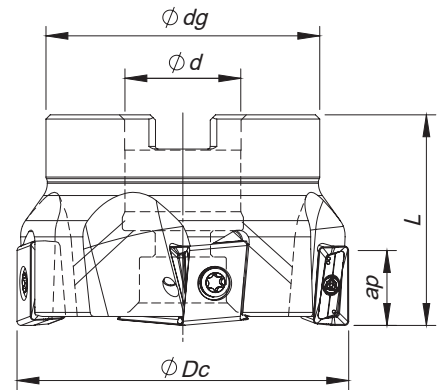

Order code Código	Reference Referência Referencia		Dimensions   Dimensões   Dimensiones (mm)				Kg	Specifications		Insert Pastilha Inserto	Stock
			ØDc	Ød	Ødg	L		Arbor Type	Ap max (mm)		
181069200	050A90390-05-05-022040		50	22	42	40	0,315	A	14,0	LNXT 1506...	
181066400	063A90390-05-05-022040		63	22	52	40	0,524	A	14,0	LNXT 1506...	
181051000	063A90390-08-05-022040		63	22	52	40	0,550	A	14,0	LNXT 1506...	
181066500	080A90390-07-05-027050		80	27	60	50	0,936	B	14,0	LNXT 1506...	
181052000	080A90390-10-05-027050		80	27	60	50	0,939	B	14,0	LNXT 1506...	
181066600	100A90390-08-05-032050		100	32	80	50	1,586	B	14,0	LNXT 1506...	
181051100	100A90390-12-05-032050		100	32	80	50	1,690	B	14,0	LNXT 1506...	
181066700	125A90390-09-05-040063		125	40	90	63	3,001	B	14,0	LNXT 1506...	
181051200	125A90390-15-05-040063		125	40	90	63	3,113	B	14,0	LNXT 1506...	
181051300	160A90390-10-05-U040063		160	40	110	63	4,470	C	14,0	LNXT 1506...	
181066800	160A90390-20-05-U040063		160	40	110	63	4,580	C	14,0	LNXT 1506...	

Stock item | Produto de stock | Itens de stock

Available under request | Disponível sobre consulta | Disponible bajo consulta

## SPARE PARTS | Complementos | Repuestos

Cutter ØDc	Insert Screw	Key (Torx)	Order separately		Order separately	
			Key (Torx - Nm)	Torque Value	Screw	DIN 6368 Wrench
A90390 - 50 - 63	P0401200	XT15	DT1530	3,0	-	-
A90390 - 80	P0401200	XT15	DT1530	3,0	J0123510	SD6368-12
A90390 - 100	P0401200	XT15	DT1530	3,0	J0164110	SD6368-16
A90390 - 125	P0401200	XT15	DT1530	3,0	J0204610	SD6368-20
A90390 - 160	P0401200	XT15	DT1530	3,0	-	-

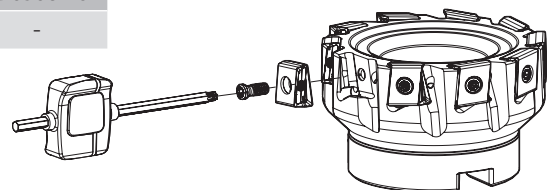

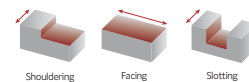

## LNXT 1506... | Inserts | Pastilhas | Plaquetas

LNXT-HP



LNXT-MP  
(PHS grade)



NEW



LNXT - MP | HP

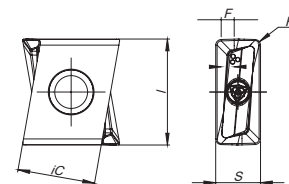

LNXT-W



LNXT-W

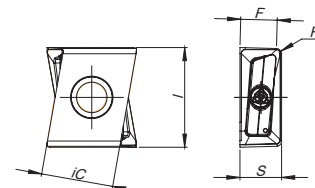

(1) Geometry code	(2) Grade code	P						M				K			N		S		H		Dimensions Dimensões Dimensiones (mm)								
		CVD		PVD				CVD		PVD		CVD			PVD		UNC	PCD	PVD							PVD	CBN		
		T9	P7	G1	G4	P3	G6	R1	G4	P3	G6	L5	L6	L9	G1	G4	G6	10	D6	P3						G6	P7	D4	
1111313	LNXT 150608 PNER-MP	⊗		⊗	⊗		⊗						⊗	○	⊗	⊗	⊗								11,0	6,35	15,0	0,8	1,8
1111590	LNXT 150612 PNER-MP				⊗		⊗						⊗	○	⊗	⊗	⊗								11,0	6,35	15,0	1,2	1,8
1111591	LNXT 150608 PNSR-HP			⊗	⊗		⊗								⊗	⊗	⊗								11,0	6,35	15,0	0,8	1,8
1111524	LNXT 150608 PNER-W			⊗									⊗	○	⊗	⊗	⊗								11,0	6,35	15,2	0,8	5,5

⊗ First choice | Primeira opção | 1ª opción

⊗ Stock item | Produto de stock | Itens de stock

○ Available under request | Disponível sobre consulta  
Disponível bajo consulta

Insert order code = (1) Geometry Code + (2) Grade Code

## GRADES SELECTION GUIDE | Guia para selecção de graus | Tabla para selección de calidades

ISO	PSM	Material	HB (Brinell)	Grades					
				← Wear Resistance			Toughness →		
				PH5705	PH7910	PH7920	PH5740	PHS740	PH7740
P	1	Unalloyed Steel	125-220		✓	✓		✓	✓
	2	Low-Alloyed Steel	220-280		✓	✓		✓	✓
	3	High-Alloyed Steel	280-380		✓	✓		✓	✓
K	7	Malleable Cast Iron	130-230	✓		✓	✓		
	8	Grey Cast Iron	180-245	✓		✓	✓		
	9	Nodular Cast iron	160-250	✓		✓	✓		

● Good Conditions  
 ● Average Conditions  
 ● Difficult Conditions

## RECOMMENDED CUTTING CONDITIONS | Condições de corte recomendadas | Condiciones de corte recomendables

ISO	PSM	Material	HB (Brinell)	Vc (m/min)					
				← Wear Resistance				Toughness →	
				PH5705	PH7910	PH7920	PH5740	PHS740	PH7740
P	1	Unalloyed Steel	125-220	-	190-280	180-250	-	140-170	140-170
	2	Low-Alloyed Steel	220-280	-	180-240	170-210	-	130-160	130-160
	3	High-Alloyed Steel	280-380	-	170-220	160-200	-	110-140	110-140
K	7	Malleable Cast Iron	130-230	190-340	180-320	170-300	170-300	-	130-250
	8	Grey Cast Iron	180-245	180-300	170-280	150-250	150-260	-	110-220
	9	Nodular Cast iron	160-250	140-250	100-240	90-210	130-220	-	80-170

ISO	PSM	Material	HB (Brinell)	Feed fz (mm/t)		
				LNXT 15... MP	LNXT 15... HP	LNXT 15... W
P	1	Unalloyed Steel	125-220	0,10-0,30	0,10-0,30	0,10-0,35
	2	Low-Alloyed Steel	220-280	0,10-0,30	0,10-0,30	0,10-0,35
	3	High-Alloyed Steel	280-380	0,10-0,25	0,10-0,25	0,10-0,35
K	7	Malleable Cast Iron	130-230	0,10-0,40	0,10-0,40	0,10-0,50
	8	Grey Cast Iron	180-245	0,10-0,35	0,10-0,35	0,10-0,50
	9	Nodular Cast iron	160-250	0,10-0,30	0,10-0,30	0,10-0,50

(Note 1) Cutting conditions  $a_e/D_c=70\%$ .

(Note 2) It's possible to occur vibrations in certain cases. Please reduce depth of cut and / or reduce cutting conditions in following cases:

- When using long shank;
- When using long tool overhang with arbor type;
- When application has poor clamping rigidity or when using a low rigidity machine.

## CHIP-BREAKER SELECTION GUIDE | Guia para aplicações do quebra- aparas | Guía para aplicación del rompevirutas

ISO	PSM	Material	HB (Brinell)	Chip-Breaker Application	
				1st choice	Difficult Operations
P	1	Unalloyed Steel	125-220	LNXT 15... MP	LNXT 15... HP
	2	Low-Alloyed Steel	220-280	LNXT 15... MP	LNXT 15... HP
	3	High-Alloyed Steel	280-380	LNXT 15... MP	LNXT 15... HP
K	7	Malleable Cast Iron	130-230	LNXT 15... MP	LNXT 15... HP
	8	Grey Cast Iron	180-245	LNXT 15... MP	LNXT 15... HP
	9	Nodular Cast iron	160-250	LNXT 15... MP	LNXT 15... HP

## WIPER INSERTS

### Rec. Cutting Conditions

- $F_w$  at least 40% larger than  $f_n$  ( $f_n - f_z \times Z$ );
- Axial depth of cut is 0,5 - 0,8mm.

### Example:

- The width of the parallel land (F) of the insert is 1,8mm
- With a cutter of 10 inserts and using a feed per tooth ( $f_z$ ) of 0,3mm, the feed per revolution ( $f_n$ ) will be 3mm, i.e. 40% bigger than the parallel land.
- To obtain a good surface finish, the feed per revolution should be a maximum of 80% of 1,8mm = 1,44mm.
- The wiper insert will have a parallel land ( $F_w$ ) with a width of approximately 5,5mm.
- Result: Feed per revolution ( $f_n$ ) could be increased from 0,8mm to 60% of 5,5mm = 3,3mm.

Note: Other limitations, such as machine power, must be taken into consideration.

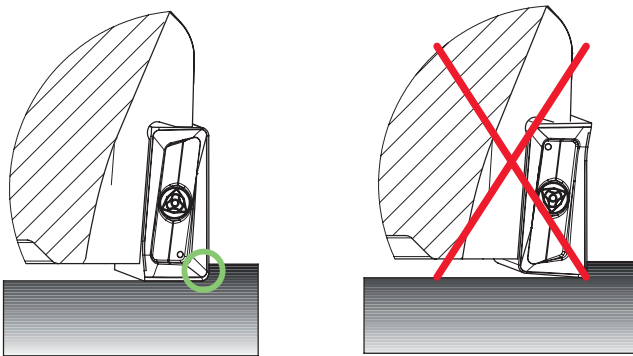

The points on the insert indicates the side that should be parallel to the workspace material.

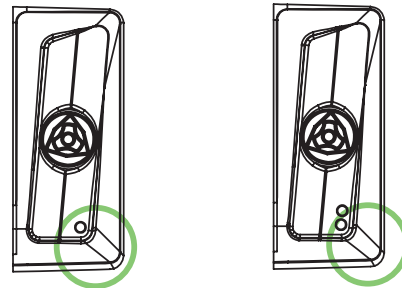

Wiper insert with 2 Right-hand cutting edges.  
The side work of the insert it's indicated by points.



## 90090 TEST REPORT



**ZIBTRPRO**  
tehnologija obdelave · vpenjalni sistemi