



ST-PHC·SB

Hydro-Dehn-Verlängerung
Hydro Chuck extension

NEW



- optimal für CT-SA Kraftspannfutter
- optimal for CT-SA Milling Chucks
- ottimale per il mandrino CT-SA
- optymalny dla oprawki CT-SA
- CT-SA frezeleme aynaları için ideal



NT TOOL

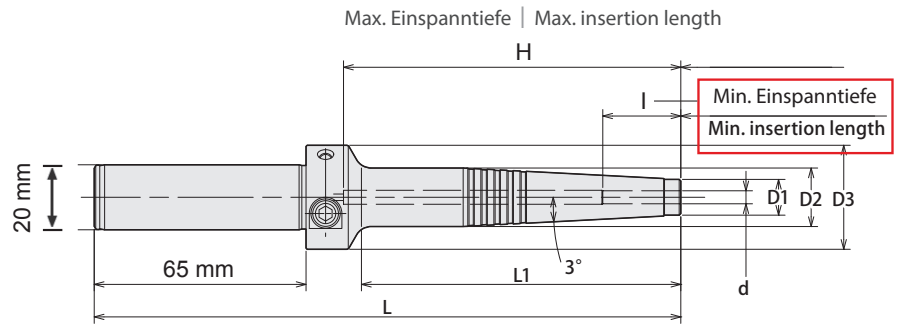

ST20

3.0
12.0



Halter Holder		d	D ₁	D ₂	D ₃	L	L ₁	I	H	
ST20	-PHC03SB -180	3	11	18	32	180	98	16	103	-
	-PHC04SB -180	4	11	18	32	180	98	19	103	-
	-PHC06SB -180	6	13	20	32	180	99	27	103	-
	-PHC08SB -180	8	15	22	32	180	99	27	101	-
	-PHC10SB -180	10	17	24	32	180	100	33	101	-
	-PHC12SB -180	12	19	26	32	180	100	36	101	HS12-d

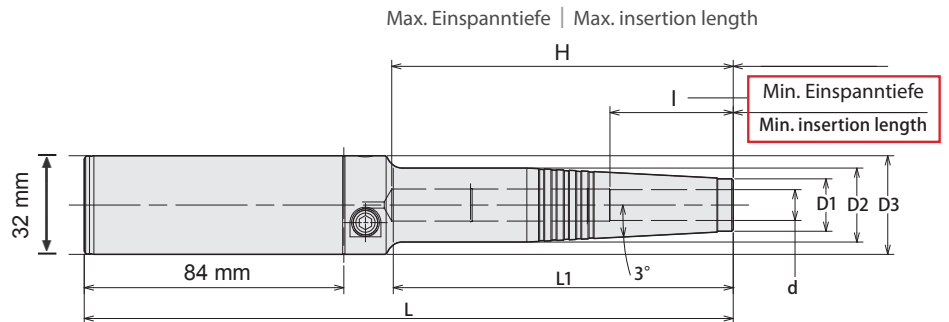

ST32

6.0
12.0



Halter Holder		d	D ₁	D ₂	D ₃	L	L ₁	I	H	
ST32	-PHC06SB -210	6	13	20	32	210	109	27	113	-
	-PHC08SB -210	8	15	22	32	210	109	27	111	-
	-PHC10SB -210	10	17	24	32	210	110	33	111	-
	-PHC12SB -210	12	19	26	32	210	110	36	111	HS12-d

- ohne Einstellschraube
- optimal für CT-SA Kraftspannfutter
- Nicht für Schrumpfaufnahmen geeignet

- without length adjustment screw
- ideal for CT-SA Milling Chuck
- Not applicable for Shrink fit

Wir empfehlen die ST-PHC-SB Verlängerungen in einem Kraftspannfutter (Typ CT-SA) oder Omega-Dehnspannfutter (Typ PHC-H) aufzunehmen. Nur dann ist eine optimale Drehmomentübertragung mit bester Rundlaufgenauigkeit gewährleistet.

We recommend to clamp ST-PHC-SB extensions in a Milling chuck (Type CT-SA) or Omega Hydro chuck (Type PHC-H). Only then an optimum transmissible torque with the best run-out can be achieved.

NT TOOL EUROPE GmbH

Siemensstrasse 17 A
61449 Steinbach, Germany

+49-(0)6171-91639 - 0

+49-(0)6171-91639-90

@ info@nttooleurope.com

www.nttooleurope.com

Fachhandel | Distributor:



ZIBTRPRO
tehnologija obdelave · vpenjalni sistemi