

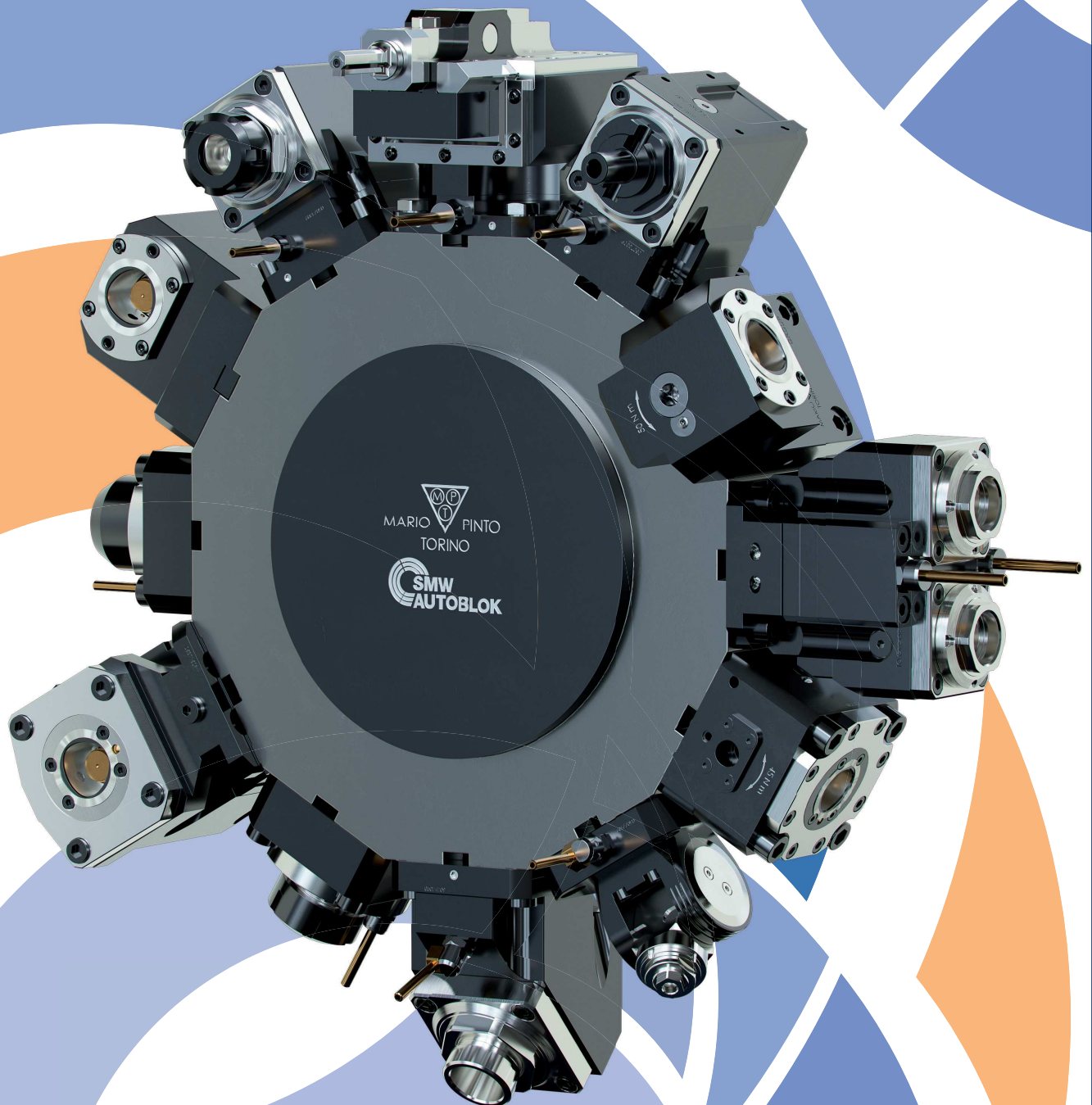

MARIO PINTO



LIVE AND STATIC TOOLING



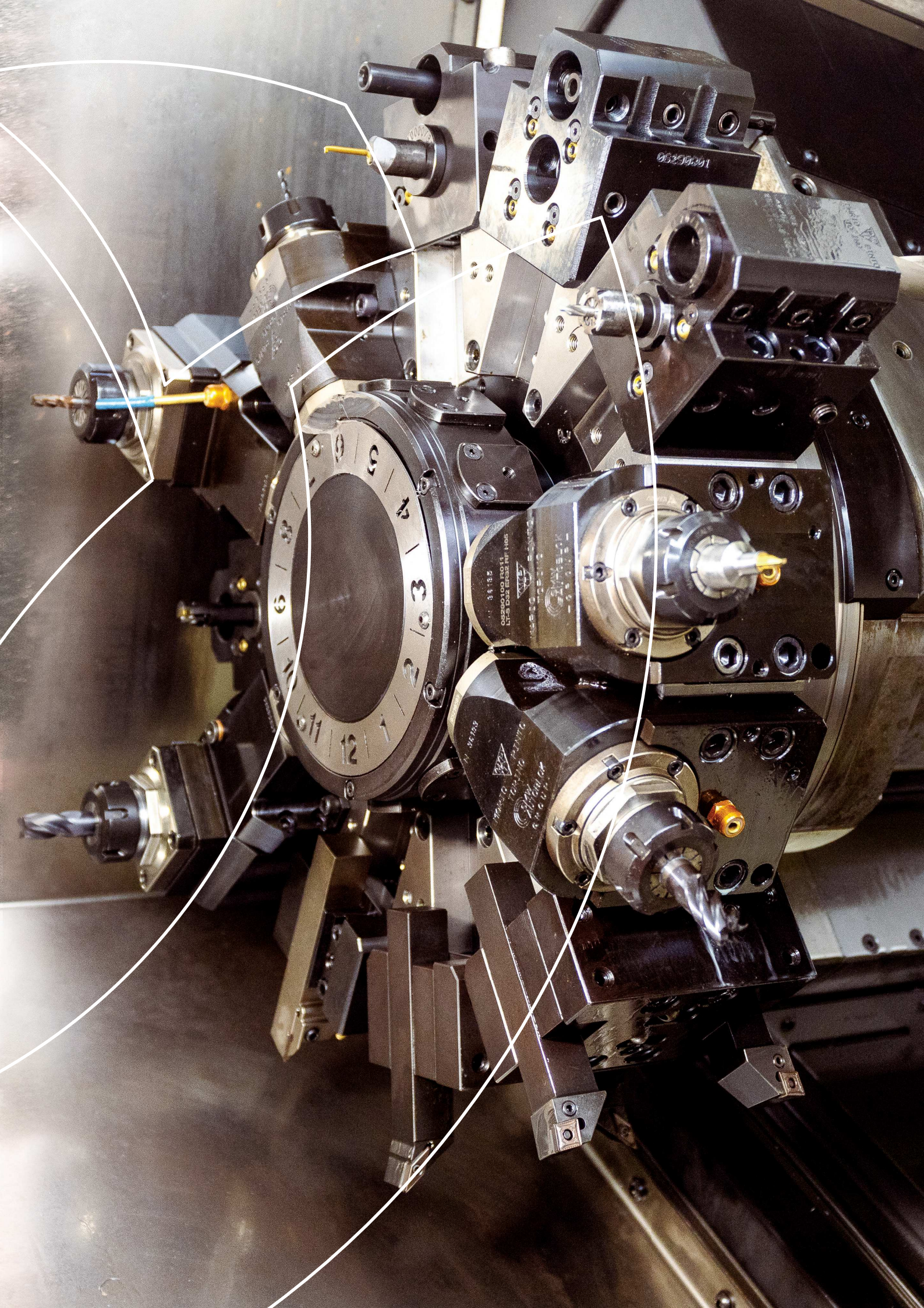

06299301

34 135
DESIGNED AND BUILT
BY S. S. BAKER

34 135
DESIGNED AND BUILT
BY S. S. BAKER

1
2
3
4
5
6
7
8
9
10
11
12

MARIO PINTO S.p.A - SMW AUTOBLOK GROUP

Specialists in live and static tooling, chucks and clamping systems

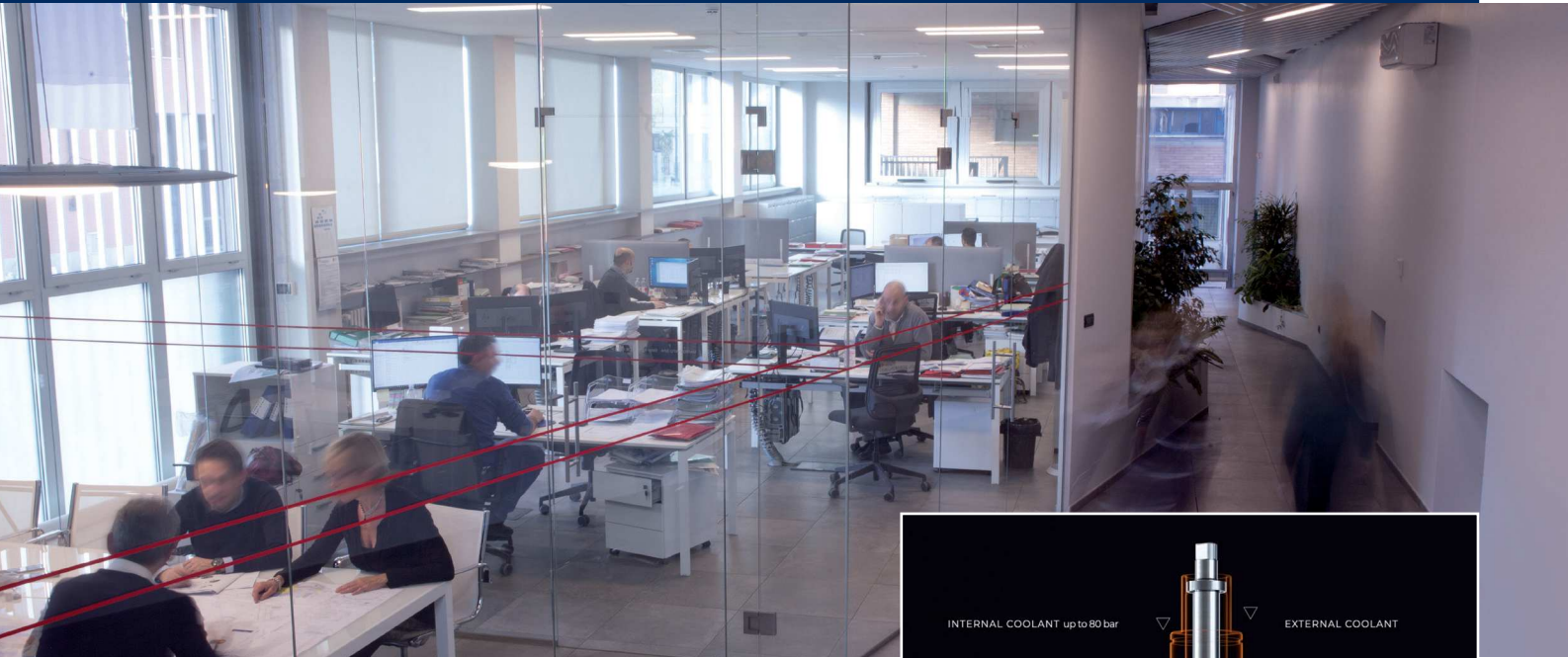

MARIO PINTO was founded in Torino in 1922 and soon became a point of reference for design and manufacturing of chucks and workholding systems for machine tools.

Using the most advanced technology, our specialised and customer-oriented team built a long and fruitful experience in the machine tool market, providing customers with the highest quality level of product and service during the years.

In the early nineties a new range was added to the program; Live and Static Toolholders for turning centres, currently representing an outstanding product on the market. Chucks and Toolholders are entirely designed and manufactured in our factory in Torino, Italy.



MARIO PINTO is part of the **SMW-AUTOBLOK** group, global leader in the workholding for machine tools, with a widespread service of pre- and aftersales assistance, covering a big number of countries.

HIGHEST PERFORMANCE • HIGHEST RIGIDITY • LONG LIFE

Extra-compact patented drive system
Hexagonal joint between shaft and gear



Toolholder completely sealed
Oversized gears made of hardened steel



LIVE AND STATIC TOOLING

Wide range available

The **MARIO PINTO Tooling** program shows a wide range of live and static toolholders for turning centers to suit all needs, providing a number of solutions and the highest versatility.

We produce toolholders with internal coolant, high pressure up to 80 bar, speed up to 12.000 rpm, multiplied and reduced transmission.

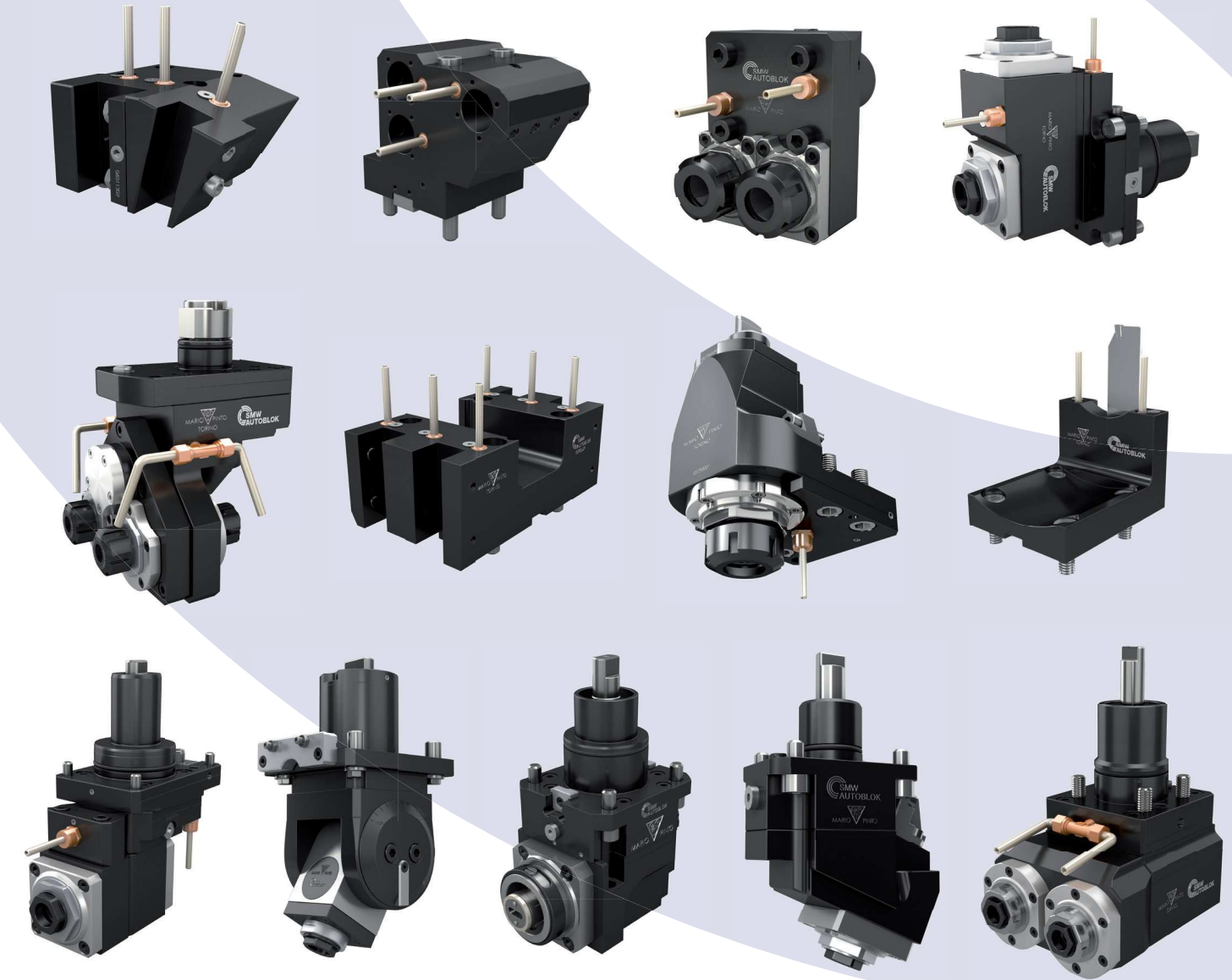

www.live-tooling.com

Our online catalogue is being updated every day with new models, and represents the ideal instrument to help customer find the proper tool. Toolholders can be sorted either by part number or machine tool builder, by machine model or drive type; a pdf drawing, showing all main details, is available for each toolholder and can be easily downloaded; or you can print a short catalogue, including all available toolholders for a specific machine model/machine tool builder.

SLOTING TOOL

- Suitable for all turning machines with radial turret
- Available with stroke 25, 35 or 65 mm
- Personalised solutions including insert-holders and cutting tools, expressly quoted basing on stuff, profile and slots dimensions, for great results.

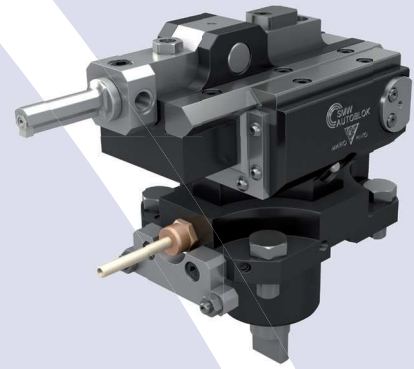

HOBGING TOOL

- Suitable for all turning machines with radial turret
- Highest rigidity and accuracy (hexagonal joint)
- Angular adjustment
- Available also in reduced transmaission
- Interchangeability of the hobbing shaft
- Highest productivity
- Possible usage as cutting-holder and/or shell-mill

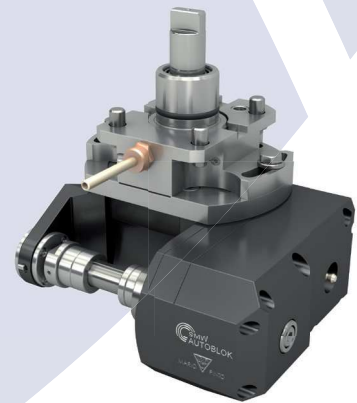

LIVE TOOLING WITH QUICK CHANGE CAPTO®

- Highest accuracy and rigidity
- Multiple solutions, highest flexibility
- Internal coolant up to 80 bar
- Speed up to 12.000 rpm
- Sizes C3 - C4 - C5 - C6
- Available for rotating and static toolholders



STEADY RESTS FOR TURRETS

Alternative for turning of bars without secondary spindle.

- Highest centering precision
- Highest support rigidity assured by three contact points
- Direct mounting on the turret, no connecting parts necessary
- Spring-operated opening / closing with coolant
- Several models available with different clamping capacity considering the size of the machine



WORLDWIDE SALES NET



Our plants are located in Italy - Caprie Novaretto, Torino, Pavia, Lainate – and Germany - Meckenbeuren. While distribution in Italy is provided by a qualified technical and commercial staff, our international sales net is located in UK, USA, Japan, China, India, Spain, France, Mexico, Taiwan, Czech Republic, Russia, South Korea, Poland, Sweden, Turkey, Ukraine and Belarus; everywhere ready to assist customers at each step of the sales process.



MARIO PINTO



Matr. 10705701 – 05/21

DISTRIBUTED BY:



ZIBTRPRO
tehnologija obdelave · vpenjalni sistemi

MARIO PINTO S.p.A. unipersonale
Strada delle Cacce, 21 - 10135 Torino - Italy
Ph. +39 0113918811 (r.a.)
www.mariopinto.it - E-mail: info@mariopinto.it



AZIENDA CON
SISTEMA DI GESTIONE QUALITÀ
CERTIFICATO DA DNV
ISO 9001

www.live-tooling.com