

SPECIAL TOOLS

Customized Tool for
Individual Requirements

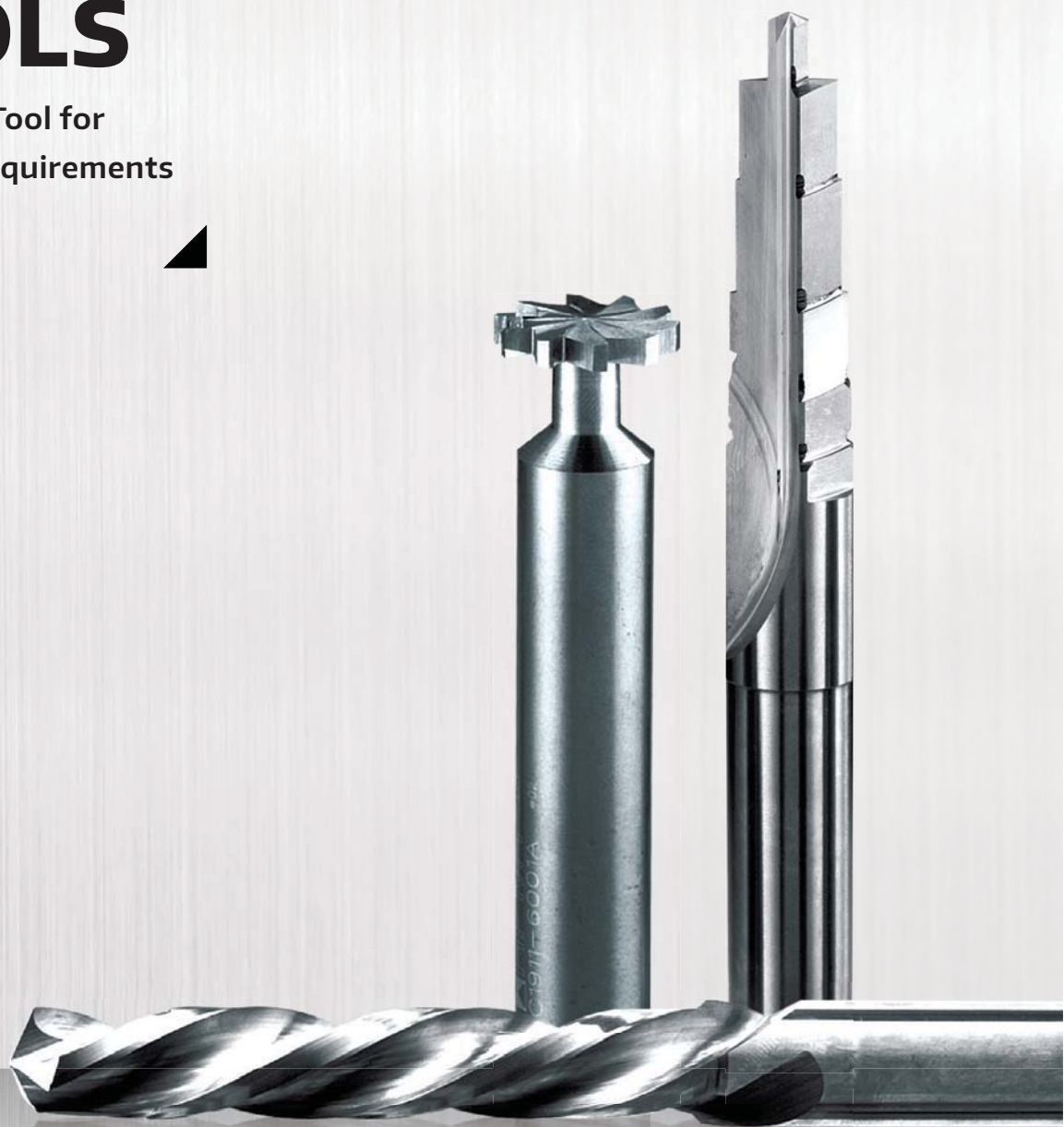

ENDMILL

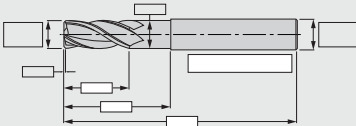

STEP ENDMILL



BALLNOSE

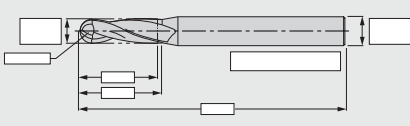

ENDMILL WITH CORNER RADIUS

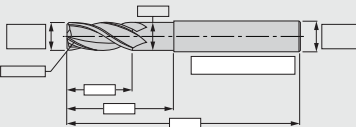

CORNER RADIUS CUTTER

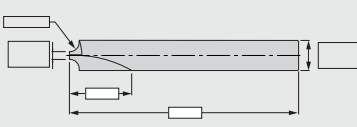

TAPER BALLNOSE

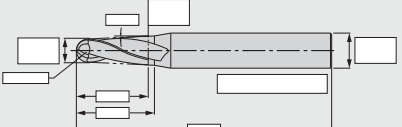

TAPER ENDMILL

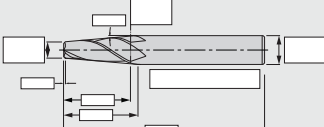

STEP REAMER

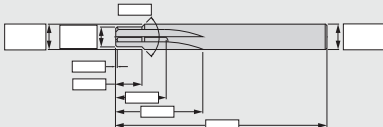

STRAIGHT FLUTE REAMER

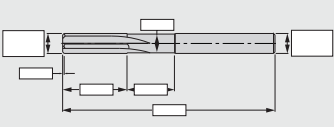

TAPER ENDMILL WITH CORNER RADIUS

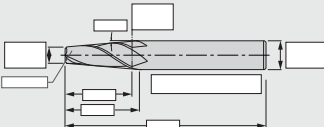

T-SLOT ENDMILL

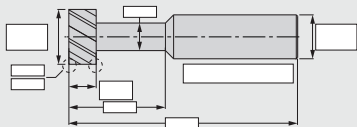

SPIRAL REAMER

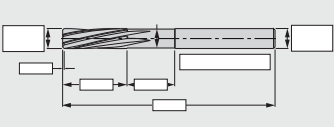

TWIST DRILL

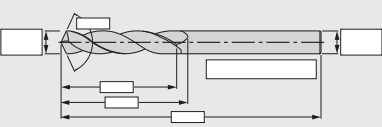

STEP TWIST DRILL

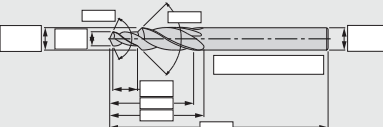

BURNISHING DRILL

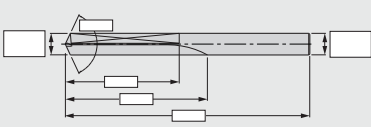

NC SPOT DRILL

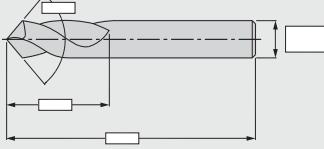

CENTER DRILL

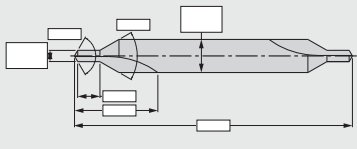

STEP BURNISHING DRILL

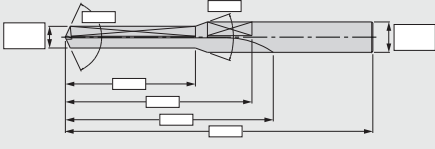

ENDMILLS

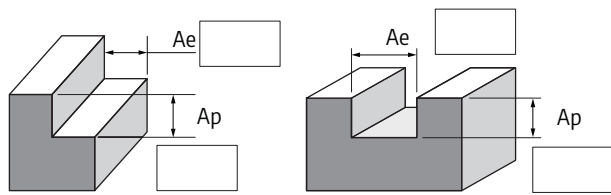

NUMBER OF FLUTE

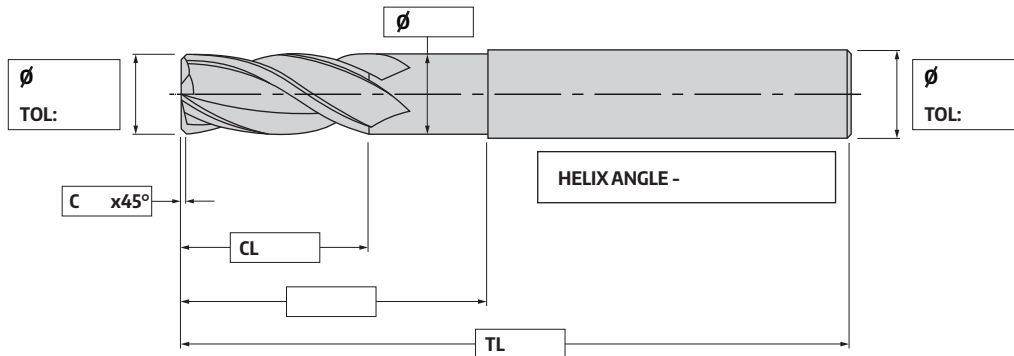
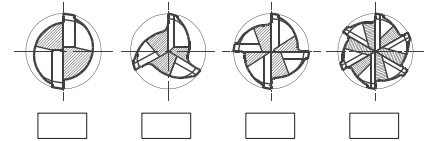

Customer's Name			Material	VHM	
Person (Mr/Ms)			Material to be Cut		
Enquiry Number			Coating		
Cutting Conditions	Vc:	Vf:	Coolant	Dry	Wet
Date:	Quantity:		Remark		

ENDMILLS WITH CORNER RADIUS

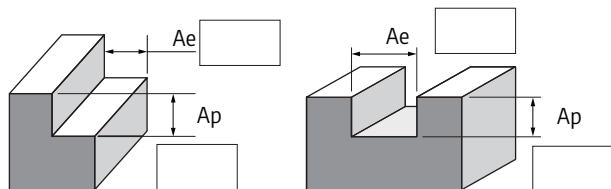

NUMBER OF FLUTE

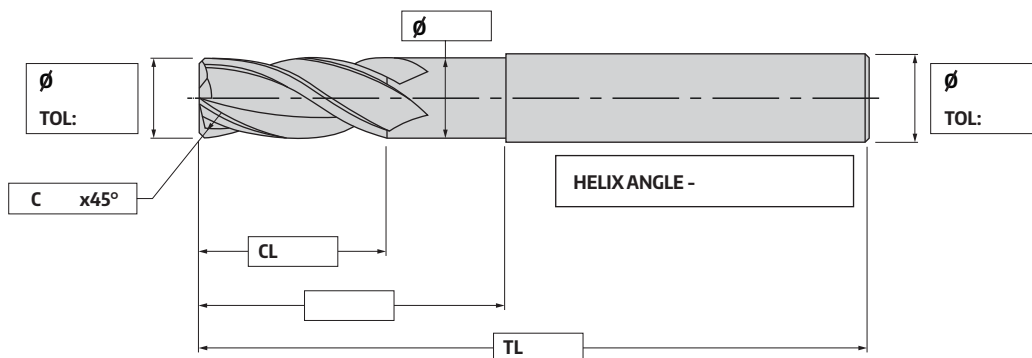
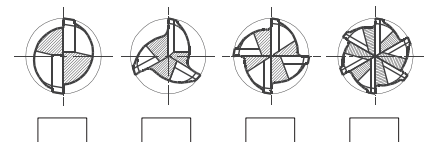

Customer's Name			Material	VHM	
Person (Mr/Ms)			Material to be Cut		
Enquiry Number			Coating		
Cutting Conditions	Vc:	Vf:	Coolant	Dry	Wet
Date:	Quantity:		Remark		

STEP ENDMILL

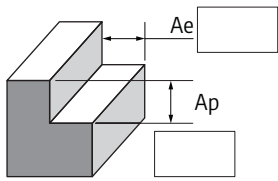

NUMBER OF FLUTE

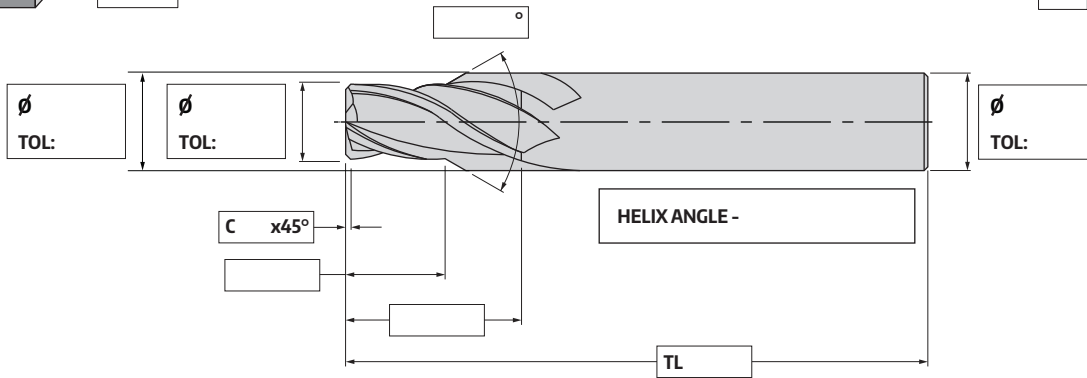
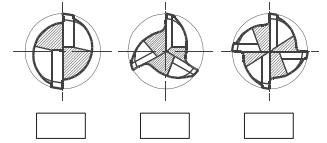

Customer's Name			Material	VHM	
Person (Mr/Ms)			Material to be Cut		
Enquiry Number			Coating		
Cutting Conditions	Vc:	Vf:	Coolant	Dry	Wet
Date:	Quantity:		Remark		

CORNER RADIUS CUTTER



NUMBER OF FLUTE

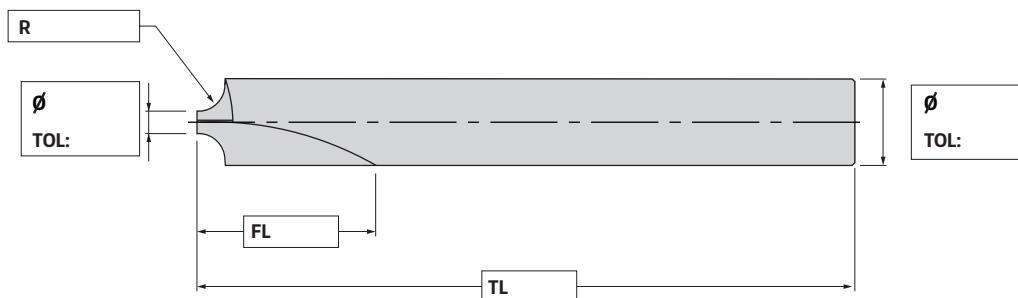
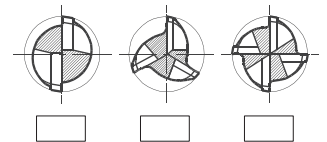

Customer's Name			Material	VHM	
Person (Mr/Ms)			Material to be Cut		
Enquiry Number			Coating		
Cutting Conditions	Vc:	Vf:	Coolant	Dry	Wet
Date:	Quantity:		Remark		

BALLNOSE



NUMBER OF FLUTE

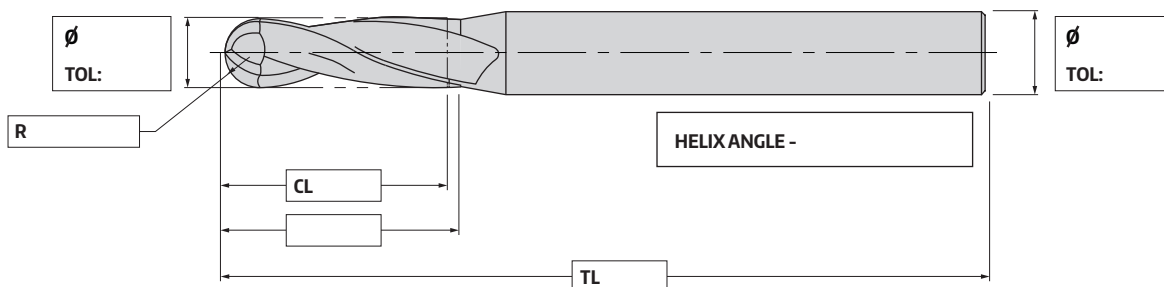
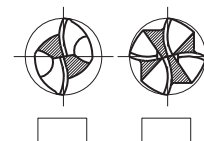

Customer's Name			Material	VHM	
Person (Mr/Ms)			Material to be Cut		
Enquiry Number			Coating		
Cutting Conditions	Vc:	Vf:	Coolant	Dry	Wet
Date:	Quantity:		Remark		

TAPER BALLNOSE



NUMBER OF FLUTE

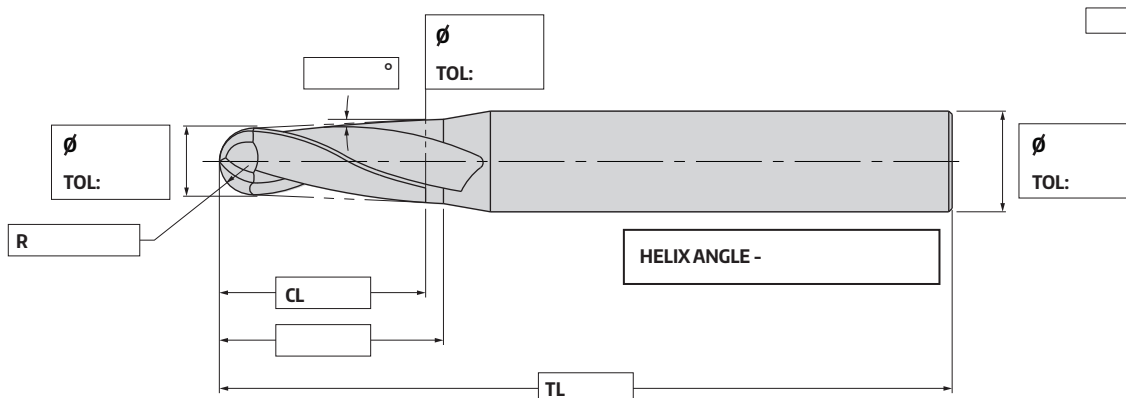
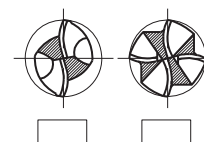

Customer's Name			Material	VHM	
Person (Mr/Ms)			Material to be Cut		
Enquiry Number			Coating		
Cutting Conditions	Vc:	Vf:	Coolant	Dry	Wet
Date:	Quantity:		Remark		

TAPER ENDMILL



NUMBER OF FLUTE

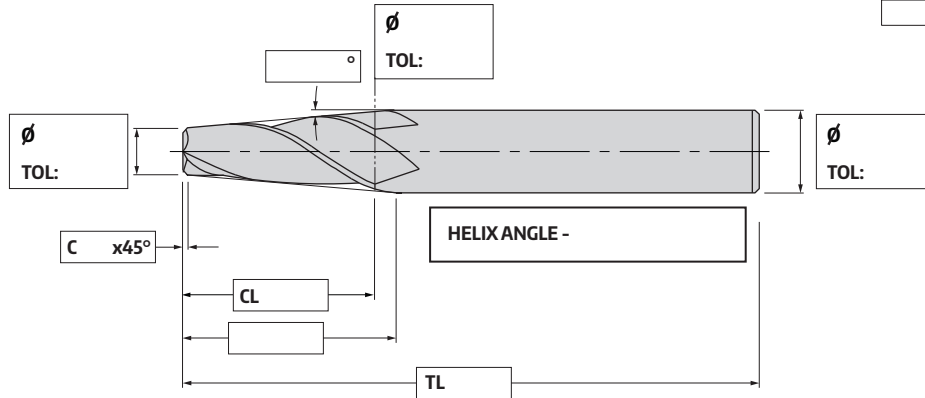
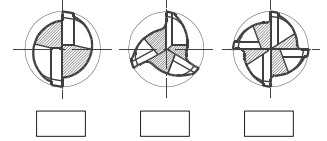

Customer's Name			Material	VHM	
Person (Mr/Ms)			Material to be Cut		
Enquiry Number			Coating		
Cutting Conditions	Vc:	Vf:	Coolant	Dry	Wet
Date:	Quantity:		Remark		

TAPER ENDMILL WITH CORNER RADIUS



NUMBER OF FLUTE

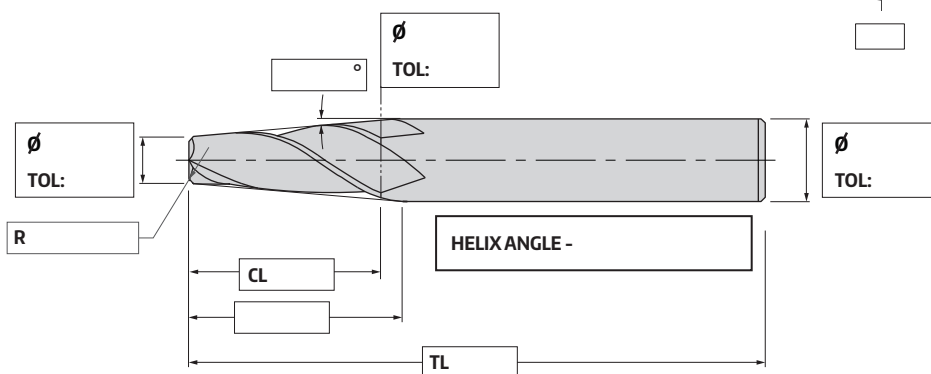
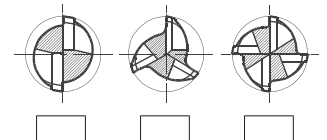

Customer's Name			Material	VHM	
Person (Mr/Ms)			Material to be Cut		
Enquiry Number			Coating		
Cutting Conditions	Vc:	Vf:	Coolant	Dry	Wet
Date:	Quantity:		Remark		

STEP REAMER



TYPE OF FLUTE

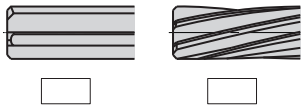

HELIX ANGLE -

NUMBER OF FLUTE

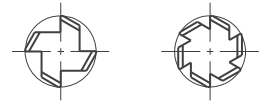

LEFT HAND SPIRAL LEFT HAND CUTTING
 RIGHT HAND SPIRAL RIGHT HAND CUTTING

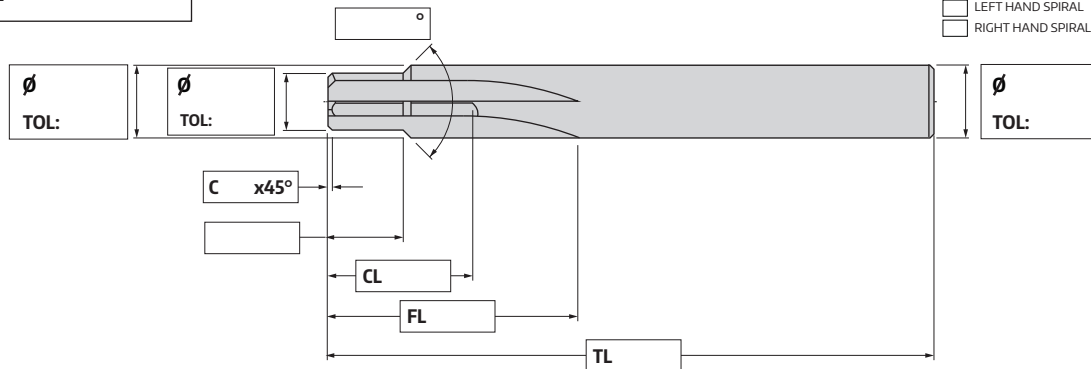

Customer's Name			Material	VHM	
Person (Mr/Ms)			Material to be Cut		
Enquiry Number			Coating		
Cutting Conditions	Vc:	Vf:	Coolant	Dry	Wet
Date:	Quantity:		Remark		

T-SLOT CUTTER



NUMBER OF FLUTE

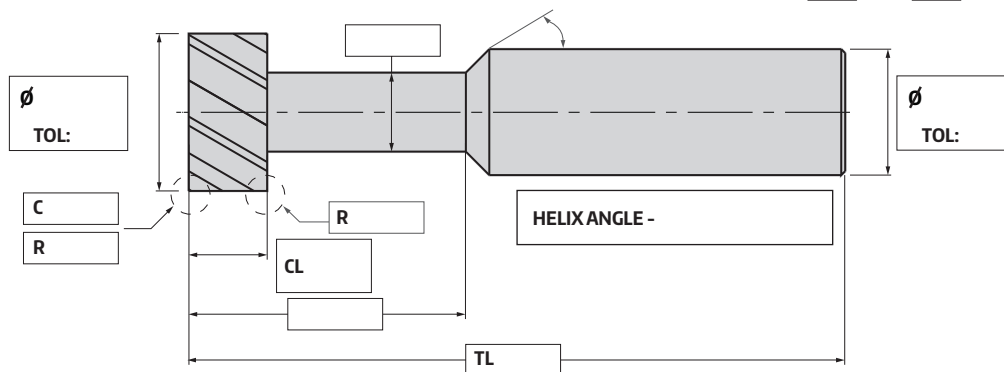
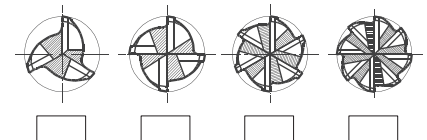

Customer's Name			Material	VHM	
Person (Mr/Ms)			Material to be Cut		
Enquiry Number			Coating		
Cutting Conditions	Vc:	Vf:	Coolant	Dry	Wet
Date:	Quantity:		Remark		

STRAIGHT FLUTE REAMER



NUMBER OF FLUTE

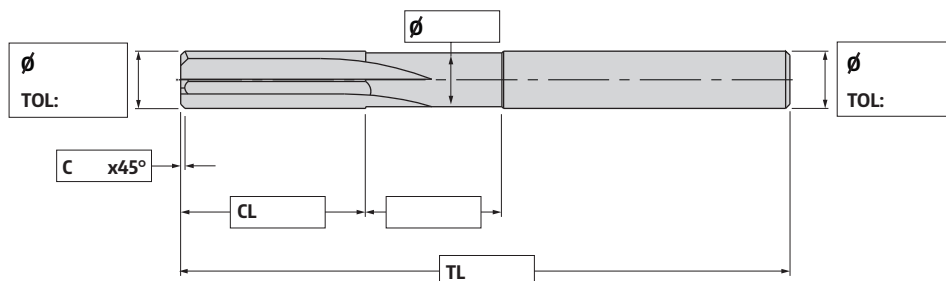
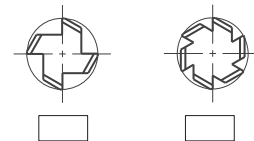

Customer's Name			Material	VHM	
Person (Mr/Ms)			Material to be Cut		
Enquiry Number			Coating		
Cutting Conditions	Vc:	Vf:	Coolant	Dry	Wet
Date:	Quantity:		Remark		

SPIRAL REAMER



HIGH SPIRAL

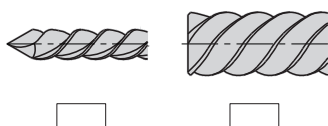

NUMBER OF FLUTE

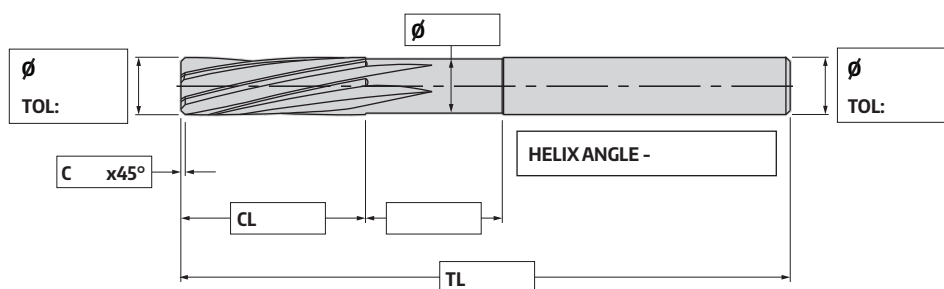
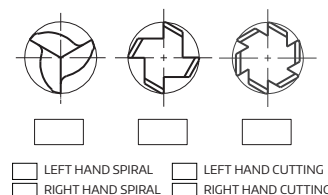

Customer's Name			Material	VHM	
Person (Mr/Ms)			Material to be Cut		
Enquiry Number			Coating		
Cutting Conditions	Vc:	Vf:	Coolant	Dry	Wet
Date:	Quantity:		Remark		

TWIST DRILL



NUMBER OF FLUTE

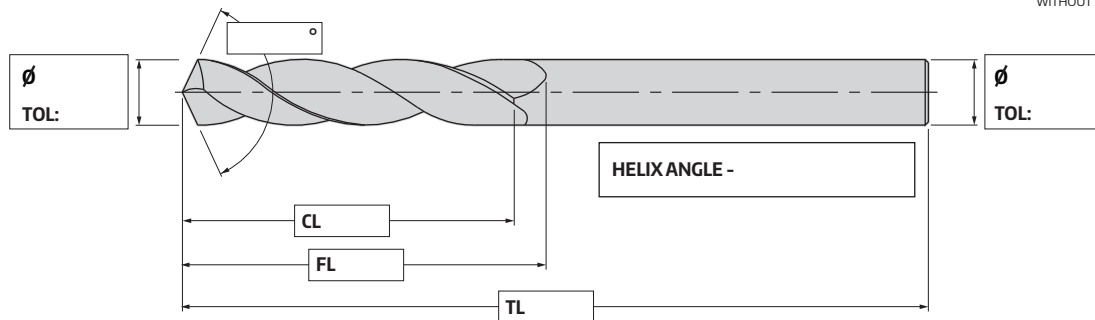
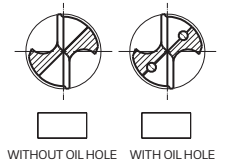

Customer's Name			Material	VHM	
Person (Mr/Ms)			Material to be Cut		
Enquiry Number			Coating		
Cutting Conditions	Vc:	Vf:	Coolant	Dry	Wet
Date:	Quantity:		Remark		

NC SPOT DRILL

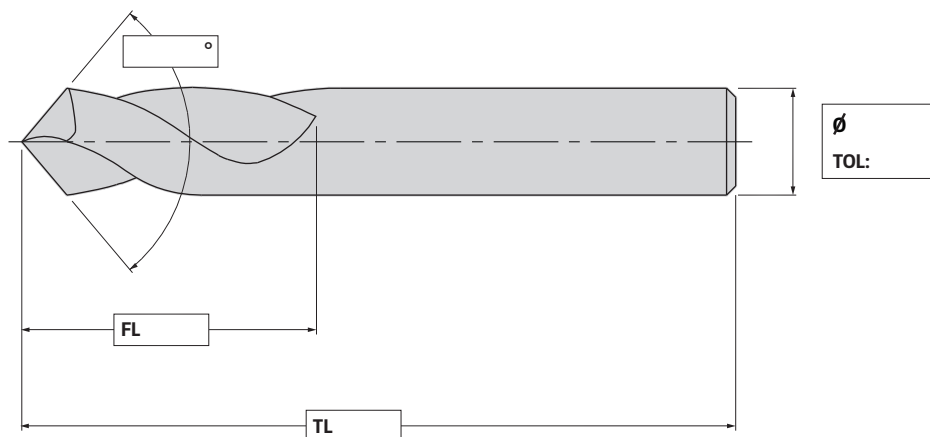

Customer's Name			Material	VHM	
Person (Mr/Ms)			Material to be Cut		
Enquiry Number			Coating		
Cutting Conditions	Vc:	Vf:	Coolant	Dry	Wet
Date:	Quantity:		Remark		

STEP TWIST DRILL

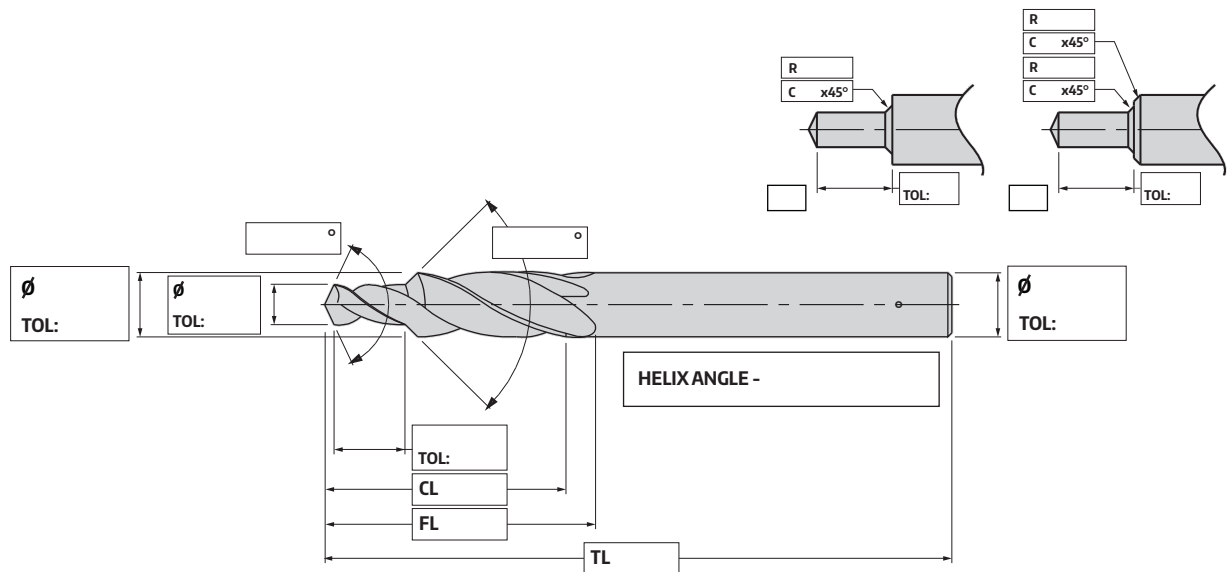

Customer's Name		Material	VHM	
Person (Mr/Ms)		Material to be Cut		
Enquiry Number		Coating		
Cutting Conditions	Vc:	Vf:	Coolant	Dry Wet
Date:	Quantity:	Remark		

CENTER DRILL



TYPE OF FLUTE

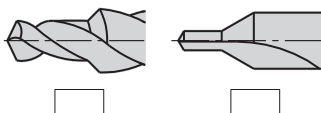

HELIX ANGLE -

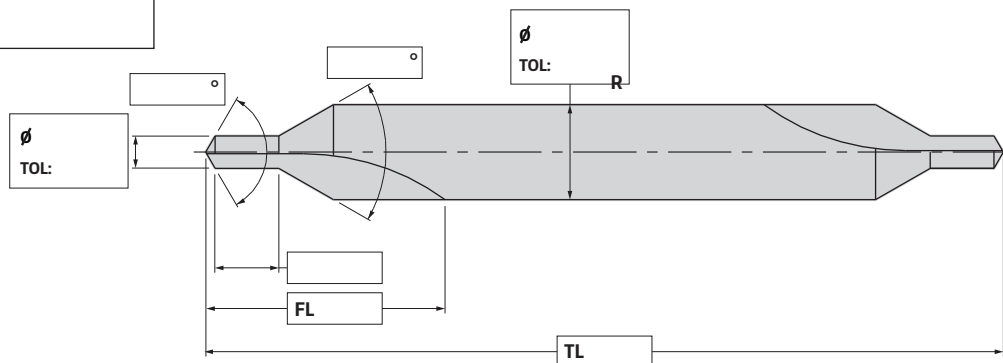

Customer's Name		Material	VHM	
Person (Mr/Ms)		Material to be Cut		
Enquiry Number		Coating		
Cutting Conditions	Vc:	Vf:	Coolant	Dry Wet
Date:	Quantity:	Remark		

BURNISHING DRILL

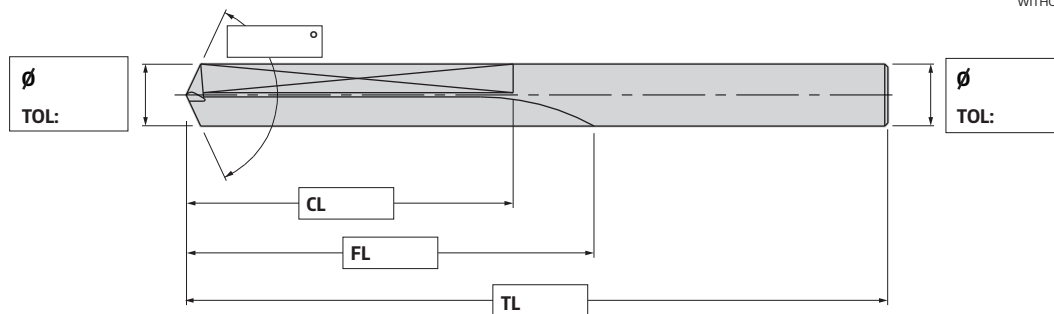
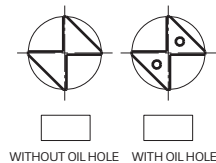

Customer's Name		Material	VHM	
Person (Mr/Ms)		Material to be Cut		
Enquiry Number		Coating		
Cutting Conditions	Vc:	Vf:	Coolant	Dry Wet
Date:	Quantity:	Remark		

STEP BURNISHING DRILL

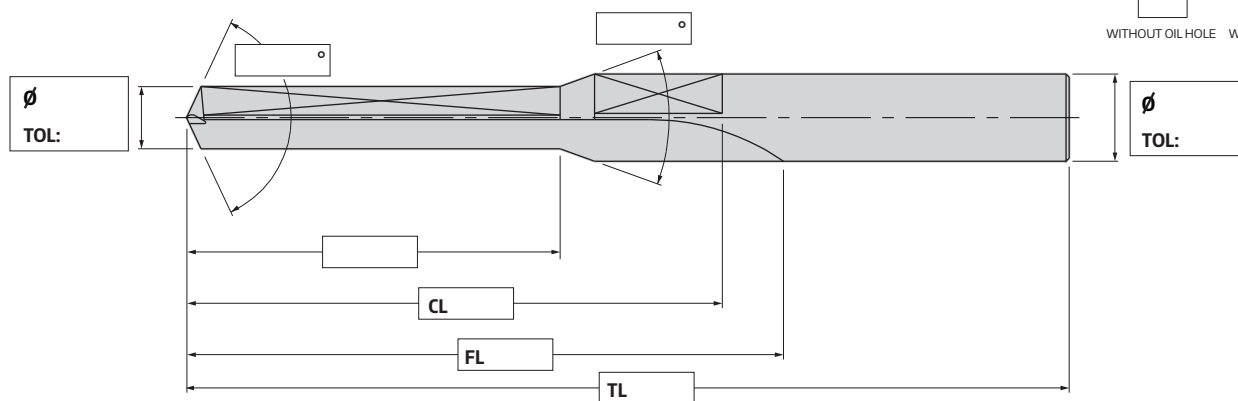
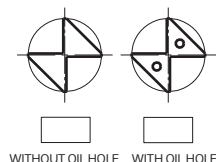

Customer's Name		Material	VHM	
Person (Mr/Ms)		Material to be Cut		
Enquiry Number		Coating		
Cutting Conditions	Vc:	Vf:	Coolant	Dry Wet
Date:	Quantity:	Remark		