

PRODUCT NEWS

PN-E-017

NEW PRODUCT

NEW

High speed • High productivity

 **DIJET**®

SKS EXTREME

for high feed machining.

G-Body

EXSKS type

■ Facemill type: $\phi 50 \sim \phi 160$



Next-generation high feed machining cutter

Improved insert strength by 1.5 times compared with conventional tool.



7.5mm
Insert thickness

Double-side insert (6 corners)

Adopted PVD coated grade "JC7560" & "JC8118" and new PVD coated grade "JC8050".



Possible to high feed machining on $f_z=2\text{mm/t}$ in case of Max. depth of cut (a_p) = 3mm.

DIJET GmbH • www.dijet.de

Feature of product

"SKS EXTREME" EXSKS type, next-generation high feed machining cutter

Features 1

Possible to high feed machining on $fz=2\text{mm/t}$ in case of Max. depth of cut (ap)= 3mm.

Features 2

Economical double-side insert (6 corners).



Features 3

Insert thickness: 7.5mm improved strength by 1.5 times compared with conventional tool.



Features 4

Due to wedge-shaped binding face of insert, only single screw clamp prevents movement of inserts with changing corner of inserts easily.

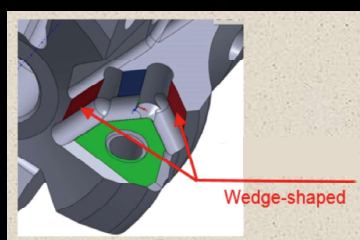

G-Body

High Rigid
G-Body



Features 5

3 insert grades PVD coated grade "JC7560", "JC8118" & new PVD coated grade "JC8050" can be widely applied from general & mold steel to high hardened die steel & stainless steel.

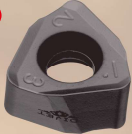
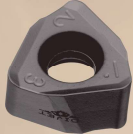
 NEW From general & mold steel to stainless steel. JC8050	 For mold steel more than 38HRC, high hardened die steel less than 50HRC & cast iron. JC8118	 Improved heat impact resistance, for general & mold steel less than 36HRC. JC7560
--	--	---

Application

ISO	P					M					K				H			
	P01	P10	P20	P30	P40	M01	M10	M20	M30	M40	K01	K10	K20	K30	H01	H10	H20	
Applicable range			NEW JC8050					NEW JC8050										
			JC8118											JC8118			JC8118	
				JC7560						JC7560								

Adopted 3 insert grades: PVD coated grade "JC7560" improved fracture toughness & heat impact resistance. PVD coated grade "JC8118" achieved longer tool life for mold steel, high hardened die steel less than 50HRC & cast iron. And new PVD coated grade "JC8050", that adopted carbide substrate with improved fracture toughness & coating layer with improved wear resistance, can be widely applied for carbon steel, mold steel, & stainless steel.

Features 6

Possible to stable high feed machining in case of long overhung length over $L/D=6$.

Features 7

Excellent in ramping and helical interpolation, and possible to high efficient pocket milling.

※ Possible to Max. ramping angle 3° in case of using $\phi 63\text{mm}$ facemill.

Cutting performance

Cutting force comparison

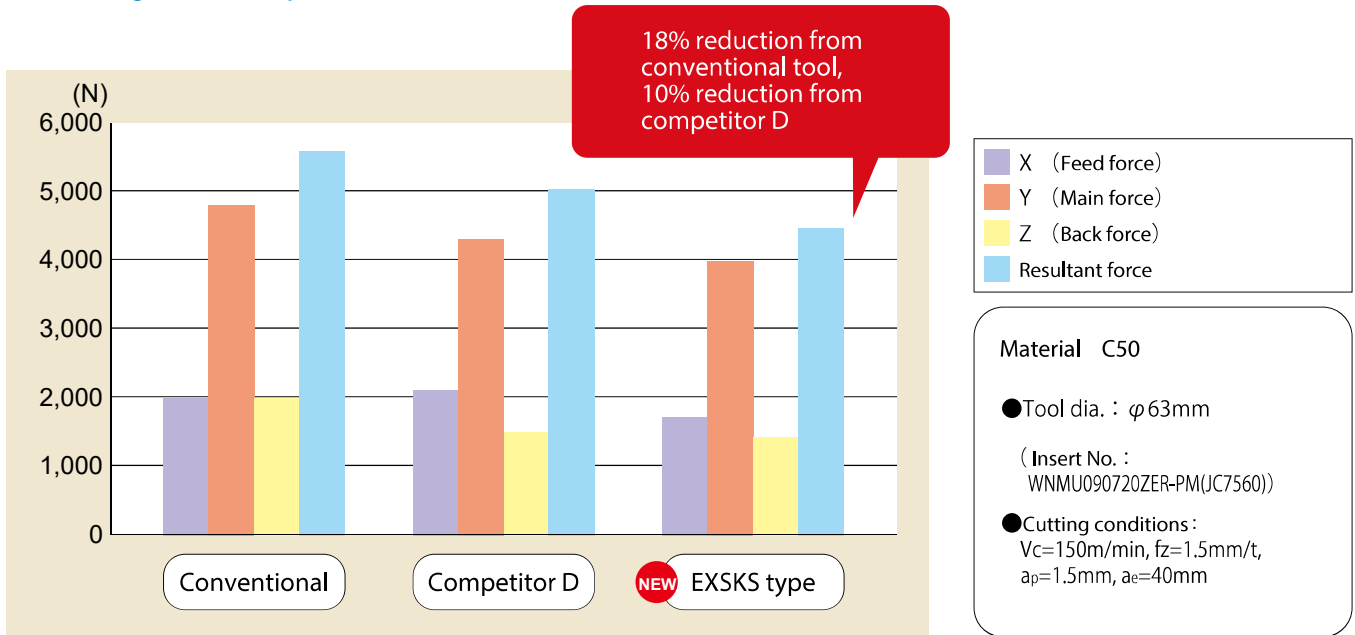

Tool life comparison

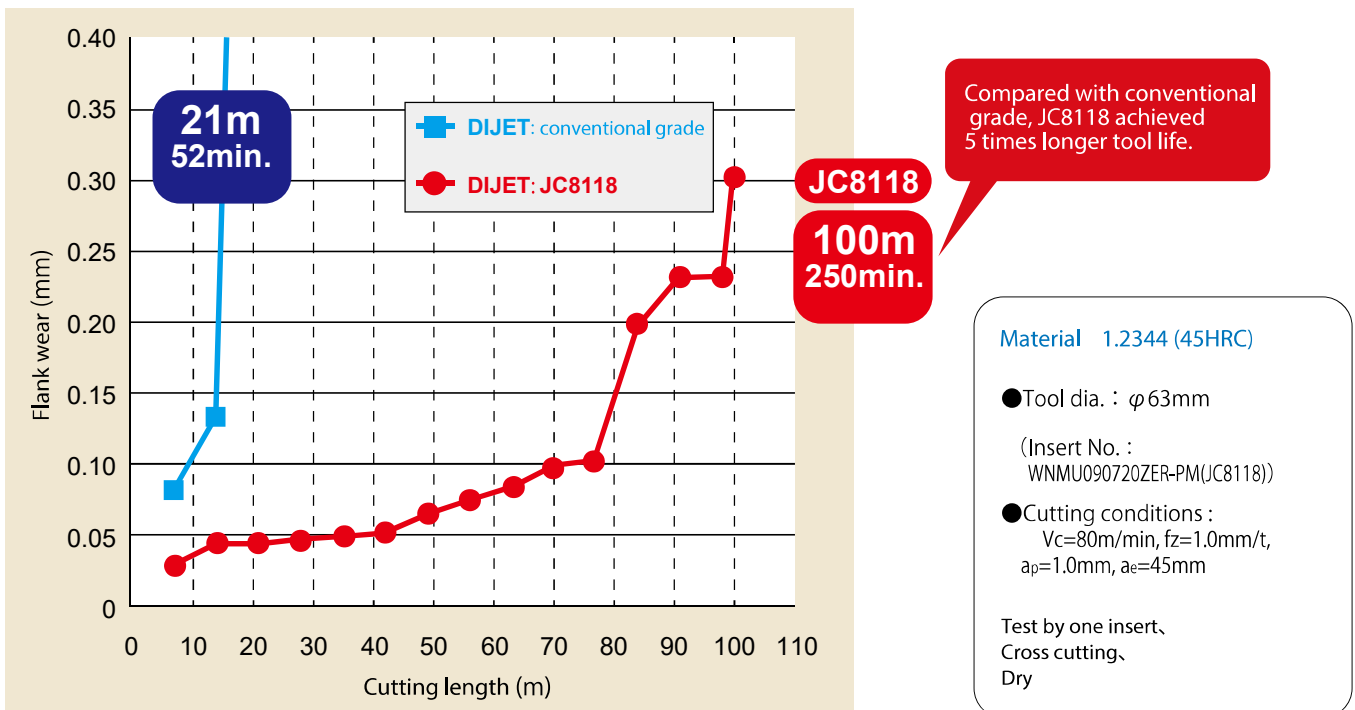

Line up

Facemill type

● Fig.1 Through coolant hole

● Fig.2 Without coolant hole

● Fig.3 Through coolant hole

G-Body

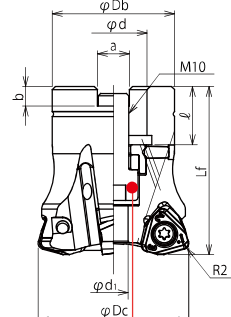
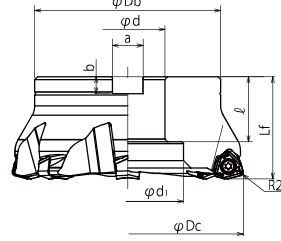
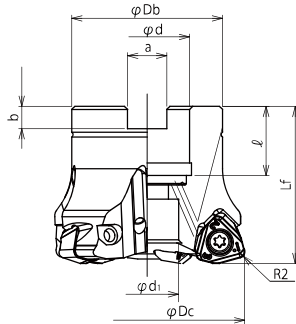

Set bolt built into the cutter body

NEW Coarse pitch type achieved low cutting force & smooth chip ejection.

Body (Metric Bore)

Type	Item code	Stock	No. of inserts	Dimensions (mm)								Set bolt	Weight (kg)	Fig.	Inserts	
				ϕDc	Lf	ϕDb	ϕd	ϕd_1	a	b	ℓ					
Metric Bore	NEW EXSKS-3050R-22	□	3	50	55	40	22	9.6	10.4	6.3	19	M10×1.5×25★	Head cap screw (JIS standard)	0.4	3	WNMU090720 ZER-PM
	EXSKS-4050R-22	●	4	50	55	40	22	9.6	10.4	6.3	19	M10×1.5×25★		0.3	3	
	EXSKS-4052R-22	●	4	52	50	40	22	17	10.4	6.3	20	M10		0.4	1	
	NEW EXSKS-4063R-22	□	4	63	50	48	22	17	10.4	6.3	20	M10		0.5	1	
	EXSKS-5063R-22	●	5	63	50	48	22	17	10.4	6.3	20	M10		0.5	1	
	EXSKS-5063R-27	●	5	63	50	48	27	20	12.4	7	22	M12×1.75×30★		0.5	1	
	EXSKS-5066R-27	●	5	66	50	48	27	20	12.4	7	22	M12×1.75×30★		0.5	1	
	EXSKS-6080R-27	●	6	80	55	65	27	37	12.4	7	22	M12×1.75×40★		0.9	1	
	EXSKS-7100R-32	●	7	100	70	85	32	26	14.4	8	32	M16×2×45★		1.9	1	
	EXSKS-8125R-40	●	8	125	70	100	40	32	16.4	9	35	M20×2.5×45★		3.9	1	
EXSKS-9160R-40	●	9	160	55	100	40	85	16.4	9	35	M20	Clamp bolt	3.9	2		

●: Standard stock items □: Stock in Japan
 Note) 1. All cutters are supplied without inserts.
 Note) 2. ★ mark shows: these cutter bodies are equipped with the set bolt because of the specified bolt size. Except for these cutter bodies, please use the set bolt equipped with arbor.
 Note) 3. All cutters are supplied without wrench & MOLY since February 2019 for our stock production.

Clamp screw	Recommended torque (N·m)
CSW-513H	5.5

Parts

Clamp screw	Wrench
CSW-513H	A-20

Line up

Insert

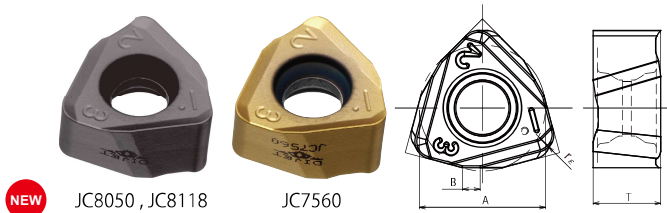

Item code	Tolerance	NEW PVD Coated			Dimensions (mm)			
		JC8050	JC8118	JC7560	A	T	B	rε
WNMU090720ZER-PM	M	●	●	●	14	7.66	1.94	2

● : Standard stock items

10 inserts per case.

Each grade shows different mark around the hole for tool proof.

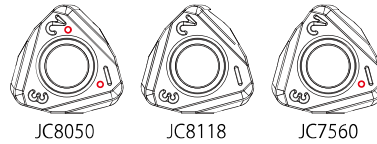

Cutting data

1. High feed machining on mold steel

Surface roughing

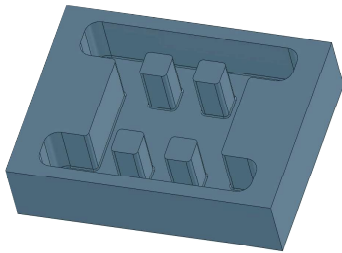

Result

Achieved high metal removal rate ($Q=756\text{cm}^3/\text{min}$) by 2.4 times compared with conventional tool. And showed normal wear after 80min.(machining at Max. main spindle load)

Work	Part name	Cavity mold	
	Material	Mold steel (heat-treated)	
	Hardness	30-34HRC	
Tool	Tool No.	EXSKS-7100R	
	Insert No.	WNMU090720ZER-PM (JC7560)	
Cutting conditions	Cutting speed	n	325 (min ⁻¹)
		V_c	102 (m/min)
	Feed speed	V_f	3,980 (mm/min)
		f_z	1.75 (mm/t)
	a_p		2.5 (mm)
	a_e		76 (mm)
	Coolant		Dry
Machine		Vertical MC(24Kw)	

2. High feed machining on die structure part

face roughing

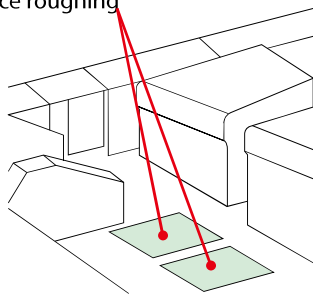

Overhung length : 220mm

Result

No chatter very smooth cutting. Achieved high metal removal rate by 1.9 times and longer tool life by 1.5 times compared with competitor D. Able to machining for 5 hours.

Work	Part name	Die structure part	
	Material	FC350 GG35	
	Hardness	—	
Tool	Tool No.	EXSKS-6080R	
	Insert No.	WNMU090720ZER-PM (JC7560)	
Cutting conditions	Cutting speed	n	500 (min ⁻¹)
		V_c	125 (m/min)
	Feed speed	V_f	5,000 (mm/min)
		f_z	1.66 (mm/t)
	a_p		3 (mm)
	a_e		47 (mm)
	Coolant		Dry
Machine		Double column type MC	

Definition of corner shape for programming

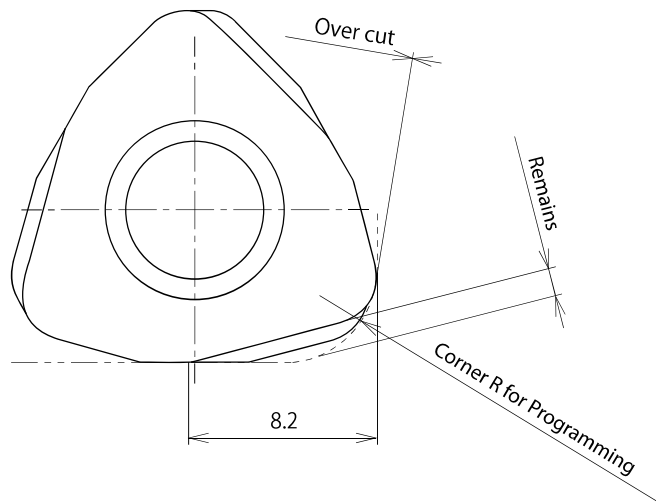

Corner R for programming	Over cut	Remains
R3.0	0	1.41
R3.5	0	1.30
R4.0	0.025	1.19

Attention for profile milling

Ramping

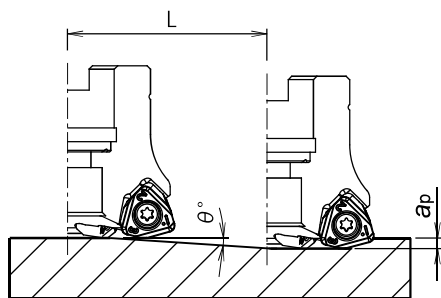

Helical interpolation

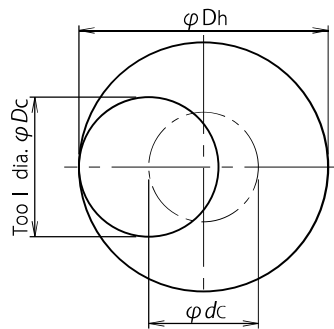

- Calculation of tool pass dia.

$$\varphi dc = \varphi Dh - \varphi Dc$$

Tool pass dia. Bore dia. Tool dia.

- Depth of cut per one circuit should not exceed max. depth of cut ap.
- Down cutting is recommended, so tool pass rotation should be counterclockwise.

Ⓞ In case of ramping and helical interpolation, apply 70% or less feed speed from standard cutting condition table.
 Ⓞ In case of drilling, apply 50% or less Z axis feed speed from standard cutting condition table.
 Ⓞ Long consecutive chips may come out in case of drilling, confirm the safe condition sufficiently.

Item code	Tool dia. (mm)	Eff. Cutting dia. (mm)	Max. depth of cut (mm)	Ramping		Helical interpolation		Max. drilling depth (mm)
				Max. ramping angle θ°	Total cutting length at Max. ap	Min. bore dia. Dh min (mm)	Max. bore dia. Dh max (mm)	
EXSKS-*050	50	33.7	3	2°24'	71.6	68	96	2
EXSKS-*052	52	35.7	3	2°24'	71.6	72	100	2
EXSKS-*063	63	46.7	3	3°	57.3	94	122	2
EXSKS-*066	66	49.7	3	2°42'	63.7	100	128	2
EXSKS-*080	80	63.6	3	2°18'	74.7	128	156	2
EXSKS-*100	100	83.6	3	1°42'	101.1	168	196	2
EXSKS-*125	125	108.5	3	1°18'	132.2	218	246	2
EXSKS-*160	160	143.5	3	1°	171.9	288	316	2

Recommended cutting conditions

Facemill type

1/3

Work materials	Grades	Tool dia. (mm)														
		50					50/52					63				
		No. of teeth 3N					No. of teeth 4N					No. of teeth 4N				
		l (mm)	a_p (mm)	n (min ⁻¹)	V_f (mm/min)	P_c (kW)	l (mm)	a_p (mm)	n (min ⁻¹)	V_f (mm/min)	P_c (kW)	l (mm)	a_p (mm)	n (min ⁻¹)	V_f (mm/min)	P_c (kW)
Carbon steel (C50,C55) Below 250HB	JC7560 JC8050 (JC8118)	~150	2	950	5,700	9.3	~150	2	950	7,600	12.4	~150	2	750	6,000	12.3
		200	1.5	800	4,800	5.9	200	1.5	800	6,400	7.8	200	1.8	680	5,440	10.0
		250	1	650	2,925	2.4	250	1	650	3,900	3.2	250	1.5	600	4,800	7.4
		300	0.6	650	1,950	1.0	300	0.6	650	2,600	1.3	300	1	550	4,400	4.5
		350	—	—	—	—	350	—	—	—	—	350	0.6	550	3,300	2.0
400	—	—	—	—	400	—	—	—	—	400	0.4	550	2,200	0.9		
Die steel (1.2344,1.2379) Below 255HB	JC7560 JC8050 (JC8118)	~150	2	950	5,700	9.3	~150	2	950	7,600	12.4	~150	2	750	6,000	12.3
		200	1.5	800	4,800	5.9	200	1.5	800	6,400	7.8	200	1.8	680	5,440	10.0
		250	1	650	2,925	2.4	250	1	650	3,900	3.2	250	1.5	600	4,800	7.4
		300	0.6	650	1,950	1.0	300	0.6	650	2,600	1.3	300	1	550	4,400	4.5
		350	—	—	—	—	350	—	—	—	—	350	0.6	550	3,300	2.0
400	—	—	—	—	400	—	—	—	—	400	0.4	550	2,200	0.9		
Mold steel (1.2311,P20) 30-36HRC	JC7560 JC8050 (JC8118)	~150	2	830	4,980	9.2	~150	2	830	6,640	12.3	~150	2	650	5,200	12.2
		200	1.5	700	4,200	5.9	200	1.5	700	5,600	7.8	200	1.8	580	4,640	9.8
		250	1	570	2,565	2.4	250	1	570	3,420	3.2	250	1.5	520	4,160	7.3
		300	0.6	570	1,710	1.0	300	0.6	570	2,280	1.3	300	1	460	3,680	4.3
		350	—	—	—	—	350	—	—	—	—	350	0.6	460	2,760	1.9
400	—	—	—	—	400	—	—	—	—	400	0.4	460	1,840	0.9		
Mold steel (1.2311,P21) 38-43HRC	JC8118 (JC8050)	~150	1.5	700	2,100	5.1	~150	1.5	700	2,800	6.8	~150	1.5	550	2,200	6.8
		200	1	600	1,800	2.9	200	1	600	2,400	3.9	200	1.2	500	2,000	4.9
		250	0.7	490	1,470	1.7	250	0.7	490	1,960	2.2	250	1	440	1,760	3.6
		300	0.4	490	735	0.5	300	0.4	490	980	0.6	300	0.7	380	1,520	2.2
		350	—	—	—	—	350	—	—	—	—	350	0.5	380	1,520	1.6
400	—	—	—	—	400	—	—	—	—	400	—	—	—	—		
Hardened die steel (1.2344, 1.2379) 42-52HRC	JC8118	~150	1.5	510	1,530	5.0	~150	1.5	510	2,040	6.6	~150	1.5	400	1,600	6.6
		200	1	460	1,380	3.0	200	1	460	1,840	4.0	200	1.2	360	1,440	4.7
		250	0.7	420	1,260	1.9	250	0.7	420	1,680	2.5	250	1	320	1,280	3.5
		300	0.4	420	630	0.5	300	0.4	420	840	0.7	300	0.7	280	1,120	2.1
		350	—	—	—	—	350	—	—	—	—	350	0.5	280	1,120	1.5
400	—	—	—	—	400	—	—	—	—	400	—	—	—	—		
Grey cast iron (GG25, GG30) Below 300HB	JC8118	~150	2.5	950	5,700	9.3	~150	2.5	950	7,600	12.4	~150	2.5	750	6,000	12.3
		200	2	800	4,800	6.2	200	2	800	6,400	8.3	200	2	680	5,440	8.9
		250	1.5	650	2,925	2.9	250	1.5	650	3,900	3.8	250	1.5	600	4,800	5.9
		300	1	650	1,950	1.3	300	1	650	2,600	1.7	300	1	550	4,400	3.6
		350	—	—	—	—	350	—	—	—	—	350	0.6	550	3,300	1.6
400	—	—	—	—	400	—	—	—	—	400	0.4	550	2,200	0.7		
Nodular cast iron (GGG50, GGG70) Below 300HB	JC8118	~150	2.5	950	5,700	9.3	~150	2.5	950	7,600	12.4	~150	2.5	750	6,000	12.3
		200	2	800	4,800	6.2	200	2	800	6,400	8.3	200	2	680	5,440	8.9
		250	1.5	650	2,925	2.9	250	1.5	650	3,900	3.8	250	1.5	600	4,800	5.9
		300	1	650	1,950	1.3	300	1	650	2,600	1.7	300	1	550	4,400	3.6
		350	—	—	—	—	350	—	—	—	—	350	0.6	550	3,300	1.6
400	—	—	—	—	400	—	—	—	—	400	0.4	550	2,200	0.7		
Stainless steel Below 250HB	JC8050 (JC7560)	~150	2	950	4,275	11.1	~150	2	950	5,700	14.8	~150	2	750	4,500	14.7
		200	1.5	800	3,600	7.0	200	1.5	800	4,800	9.4	200	1.8	680	4,080	12.0
		250	1	650	1,950	2.5	250	1	650	2,600	3.4	250	1.5	600	3,600	8.8
		300	0.6	650	1,950	1.5	300	0.6	650	2,600	2.0	300	1	550	2,640	4.3
		350	—	—	—	—	350	—	—	—	—	350	0.6	550	2,200	2.2
400	—	—	—	—	400	—	—	—	—	400	0.4	550	2,200	1.4		

l : Overhung length a_p : Depth of cut n : Spindle speed V_f : Feed speed P_c : Net power consumption

Note:

*1. The figure to be adjusted according to the machine rigidity or work rigidity.

*2. In case of chatter occurring, recommend to reduce the depth of cut a_p or Spindle speed and keep feed per tooth.

*3. If machine does not have enough power, recommend to reduce the depth of cut a_p or Spindle speed and

Feed speed.

*4. Use air blow.

Facemill type

2/3

Work materials	Grades	Tool dia. (mm)														
		63/66					80					100				
		No. of teeth 5N					No. of teeth 6N					No. of teeth 7N				
		l (mm)	a_p (mm)	n (min ⁻¹)	V_f (mm/min)	P_c (kW)	l (mm)	a_p (mm)	n (min ⁻¹)	V_f (mm/min)	P_c (kW)	l (mm)	a_p (mm)	n (min ⁻¹)	V_f (mm/min)	P_c (kW)
(Carbon steel (C50,C55) Below 250HB)	JC7560 JC8050 (JC8118)	~150	2	750	7,500	15.4	~150	2	600	7,200	18.7	~150	2	480	6,720	21.8
		200	1.8	680	6,800	12.5	200	1.8	540	6,480	15.2	200	2	430	6,020	19.6
		250	1.5	600	6,000	9.2	250	1.8	480	5,760	13.5	250	2	380	5,320	17.3
		300	1	550	5,500	5.6	300	1.5	440	5,280	10.3	300	1.5	350	4,900	11.9
		350	0.6	550	4,125	2.5	350	1	440	5,280	6.9	350	1.5	350	4,900	11.9
400	0.4	550	2,750	1.1	400	0.6	440	3,960	3.1	400	1	350	4,900	8.0		
Die steel (1.2344,1.2379) Below 255HB)	JC7560 JC8050 (JC8118)	~150	2	750	7,500	15.4	~150	2	600	7,200	18.7	~150	2	480	6,720	21.8
		200	1.8	680	6,800	12.5	200	1.8	540	6,480	15.2	200	2	430	6,020	19.6
		250	1.5	600	6,000	9.2	250	1.8	480	5,760	13.5	250	2	380	5,320	17.3
		300	1	550	5,500	5.6	300	1.5	440	5,280	10.3	300	1.5	350	4,900	11.9
		350	0.6	550	4,125	2.5	350	1	440	5,280	6.9	350	1.5	350	4,900	11.9
400	0.4	550	2,750	1.1	400	0.6	440	3,960	3.1	400	1	350	4,900	8.0		
Mold steel (1.2311,P20) 30-36HRC)	JC7560 JC8050 (JC8118)	~150	2	650	6,500	15.2	~150	2	520	6,240	18.5	~150	2	410	5,740	21.3
		200	1.8	580	5,800	12.2	200	1.8	470	5,640	15.1	200	2	370	5,180	19.2
		250	1.5	520	5,200	9.1	250	1.8	420	5,040	13.5	250	2	330	4,620	17.2
		300	1	460	4,600	5.4	300	1.5	360	4,320	9.6	300	1.5	280	3,920	10.9
		350	0.6	460	3,450	2.4	350	1	360	4,320	6.4	350	1.5	280	3,920	10.9
400	0.4	460	2,300	1.1	400	0.6	360	3,240	2.9	400	1	280	3,920	7.3		
Mold steel (1.2311,P21) 38-43HRC)	JC8118 (JC8050)	~150	1.5	550	2,750	8.4	~150	1.5	430	2,580	10.1	~150	1.5	350	2,450	11.9
		200	1.2	500	2,500	6.1	200	1.2	390	2,340	7.3	200	1.5	310	2,170	10.6
		250	1	440	2,200	4.5	250	1.2	340	2,040	6.4	250	1.2	280	1,960	7.6
		300	0.7	380	1,900	2.7	300	1	300	1,800	4.7	300	1	250	1,750	5.7
		350	0.5	380	1,900	1.9	350	0.7	300	1,800	3.3	350	1	250	1,750	5.7
400	—	—	—	—	400	0.4	300	1,800	1.9	400	0.7	250	1,750	4.0		
Hardened die steel (1.2344, 1.2379) 42-52HRC)	JC8118	~150	1.5	400	2,000	8.2	~150	1.5	320	1,920	10.0	~150	1.5	250	1,750	11.4
		200	1.2	360	1,800	5.9	200	1.2	290	1,740	7.2	200	1.5	230	1,610	10.5
		250	1	320	1,600	4.4	250	1.2	260	1,560	6.5	250	1.2	200	1,400	7.3
		300	0.7	280	1,400	2.7	300	1	220	1,320	4.6	300	1	180	1,260	5.5
		350	0.5	280	1,400	1.9	350	0.7	220	1,320	3.2	350	1	180	1,260	5.5
400	—	—	—	—	400	0.4	220	1,320	1.8	400	0.7	180	1,260	3.8		
Grey cast iron (GG25, GG30) Below 300HB)	JC8118	~150	2.5	750	7,500	15.4	~150	2.5	600	7,200	18.7	~150	2.5	480	6,720	21.8
		200	2	680	6,800	11.1	200	2	540	6,480	13.5	200	2.5	430	6,020	19.6
		250	1.5	600	6,000	7.4	250	2	480	5,760	12.0	250	2	380	5,320	13.8
		300	1	550	5,500	4.5	300	1.5	440	5,280	8.2	300	2	350	4,900	12.7
		350	0.6	550	4,125	2.0	350	1	440	5,280	5.5	350	1.5	350	4,900	9.6
400	0.4	550	2,750	0.9	400	0.6	440	3,960	2.5	400	1	350	4,900	6.4		
Nodular cast iron (GGG50, GGG70) Below 300HB)	JC8118	~150	2.5	750	7,500	15.4	~150	2.5	600	7,200	18.7	~150	2.5	480	6,720	21.8
		200	2	680	6,800	11.1	200	2	540	6,480	13.5	200	2.5	430	6,020	19.6
		250	1.5	600	6,000	7.4	250	2	480	5,760	12.0	250	2	380	5,320	13.8
		300	1	550	5,500	4.5	300	1.5	440	5,280	8.2	300	2	350	4,900	12.7
		350	0.6	550	4,125	2.0	350	1	440	5,280	5.5	350	1.5	350	4,900	9.6
400	0.4	550	2,750	0.9	400	0.6	440	3,960	2.5	400	1	350	4,900	6.4		
Stainless steel Below 250HB)	JC8050 (JC7560)	~150	2	750	5,625	18.4	~150	2	600	5,400	22.5	~150	2	480	5,040	26.2
		200	1.8	680	5,100	15.0	200	1.8	540	4,860	18.2	200	2	430	4,515	23.5
		250	1.5	600	4,500	11.1	250	1.8	480	4,320	16.2	250	2	380	3,990	20.7
		300	1	550	3,300	5.4	300	1.5	440	3,960	12.4	300	1.5	350	3,675	14.3
		350	0.6	550	2,750	2.7	350	1	440	3,168	6.6	350	1.5	350	3,675	14.3
400	0.4	550	2,750	1.8	400	0.6	440	2,640	3.3	400	1	350	3,675	9.6		

l : Overhung length a_p : Depth of cut n : Spindle speed V_f : Feed speed P_c : Net power consumption

- Note:
*1. The figure to be adjusted according to the machine rigidity or work rigidity.
*2. In case of chatter occurring, recommend to reduce the depth of cut a_p or Spindle speed and keep feed per tooth.
*3. If machine does not have enough power, recommend to reduce the depth of cut a_p or Spindle speed and Feed speed.
*4. Use air blow.

Work materials	Grades	Tool dia. (mm)									
		125					160				
		No. of teeth 8N					No. of teeth 9N				
		l (mm)	a_p (mm)	n (min ⁻¹)	V_f (mm/min)	P_c (kW)	l (mm)	a_p (mm)	n (min ⁻¹)	V_f (mm/min)	P_c (kW)
Carbon steel (C50,C55) Below 250HB	JC7560 JC8050 (JC8118)	~150	2	380	6,080	24.7	~150	2	300	5,400	28.1
		200	2	340	5,440	22.1	200	2	270	4,860	25.3
		250	2	300	4,800	19.5	250	2	240	4,320	22.5
		300	2	280	4,480	18.2	300	2	220	3,960	20.6
		350	1.5	280	4,480	13.7	350	2	220	3,960	20.6
Die steel (1.2344,1.2379) Below 255HB	JC7560 JC8050 (JC8118)	~150	2	380	6,080	24.7	~150	2	300	5,400	28.1
		200	2	340	5,440	22.1	200	2	270	4,860	25.3
		250	2	300	4,800	19.5	250	2	240	4,320	22.5
		300	2	280	4,480	18.2	300	2	220	3,960	20.6
		350	1.5	280	4,480	13.7	350	2	220	3,960	20.6
Mold steel (1.2311,P20) 30-36HRC	JC7560 JC8050 (JC8118)	~150	2	330	5,280	24.5	~150	2	260	4,680	27.8
		200	2	300	4,800	22.3	200	2	230	4,140	24.6
		250	2	260	4,160	19.3	250	2	210	3,780	22.5
		300	2	230	3,680	17.1	300	2	180	3,240	19.3
		350	1.5	230	3,680	12.8	350	2	180	3,240	19.3
Mold steel (1.2311,P21) 38-43HRC	JC8118 (JC8050)	~150	1.5	280	2,240	13.7	~150	1.5	220	1,980	15.4
		200	1.5	250	2,000	12.2	200	1.5	200	1,800	14.0
		250	1.5	220	1,760	10.7	250	1.5	180	1,620	12.6
		300	1.5	200	1,600	9.8	300	1.5	150	1,350	10.5
		350	1	200	1,600	6.5	350	1.5	150	1,350	10.5
Hardened die steel (1.2344, 1.2379) 42-52HRC	JC8118	~150	1.5	200	1,600	13.0	~150	1.5	160	1,440	15.0
		200	1.5	180	1,440	11.7	200	1.5	150	1,350	14.0
		250	1.5	160	1,280	10.4	250	1.5	130	1,170	12.2
		300	1.5	140	1,120	9.1	300	1.5	110	990	10.3
		350	1	140	1,120	6.1	350	1.5	110	990	10.3
Grey cast iron (GG25, GG30) Below 300HB	JC8118	~150	2.5	380	6,080	24.7	~150	2.5	300	5,400	28.1
		200	2.5	340	5,440	22.1	200	2.5	270	4,860	25.3
		250	2.5	300	4,800	19.5	250	2.5	240	4,320	22.5
		300	2	280	4,480	14.6	300	2.5	220	3,960	20.6
		350	1.5	280	4,480	10.9	350	2	220	3,960	16.5
Nodular cast iron (GGG50, GGG70) Below 300HB	JC8118	~150	2.5	380	6,080	24.7	~150	2.5	300	5,400	28.1
		200	2.5	340	5,440	22.1	200	2.5	270	4,860	25.3
		250	2.5	300	4,800	19.5	250	2.5	240	4,320	22.5
		300	2	280	4,480	14.6	300	2.5	220	3,960	20.6
		350	1.5	280	4,480	10.9	350	2	220	3,960	16.5
Stainless steel Below 250HB	JC8050 (JC7560)	~150	2	380	4,560	29.6	~150	2	300	4,050	33.7
		200	2	340	4,080	26.5	200	2	270	3,645	30.3
		250	2	300	3,600	23.4	250	2	240	3,240	27.0
		300	2	280	3,360	21.8	300	2	220	2,970	24.7
		350	1.5	280	3,360	16.4	350	2	220	2,970	24.7
400	1.5	280	3,360	16.4	400	1.5	220	2,970	18.5		

l : Overhung length a_p : Depth of cut n : Spindle speed V_f : Feed speed P_c : Net power consumption

Note:

*1. The figure to be adjusted according to the machine rigidity or work rigidity.

*2. In case of chatter occurring, recommend to reduce the depth of cut a_p or Spindle speed and keep feed per tooth.

*3. If machine does not have enough power, recommend to reduce the depth of cut a_p or Spindle speed and

Feed speed.

*4. Use air blow.



HEADQUARTER

DIJET Industrial Co.Ltd.

1-1-18, Kami-Higashi,

Hirano-ku, Osaka 547-0002, Japan

PHONE +81-6-6791-6781

FAX +81-6-6793-1221

MAIN OFFICE EUROPE

DIJET GmbH

Immermannstraße 9

40210 Düsseldorf, Germany

PHONE +49-211-5008820

FAX +49-211-5008823



DIJET EUROPE



DIJET GmbH



Web : www.dijet.de



Please register to DIJET-Club

dijet-club.com →



ZIBTRPRO

tehnologija obdelave · vpenjalni sistemi