

# MAGNETIC WORKHOLDING

Grinding | Pallet | EDM | Milling | Turning | Lifting

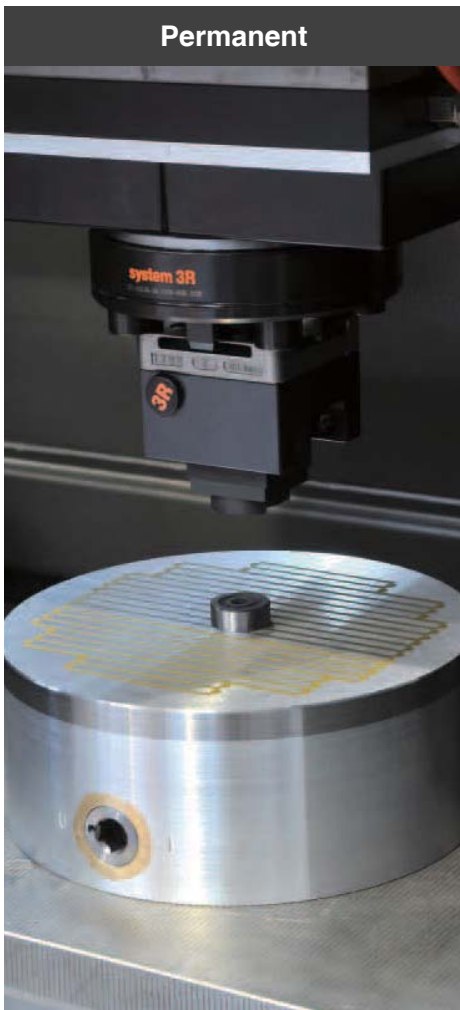

# BRISC®

## Magnetic Workholding Applications

### Table of contents



#### Grinding

EMA	-----	01
EME	-----	02
EMV	-----	03
EPB	-----	04
EPS	-----	05
EPA	-----	06
PMF	-----	07
PMT	-----	08
PMY	-----	09
NY	-----	10
EPY	-----	11

#### Pallet

PPN / PPA	-----	12
PPC / PPM	-----	13

#### Milling

PSP	-----	14
POLE EXTENSION	-----	15
PRP	-----	16
PMM	-----	17
PZP	-----	18
PCC	-----	19

#### EDM

PFD	-----	21
MBF	-----	22
NF	-----	23
PMB	-----	24
PMG	-----	25

#### Turning

NR	-----	26
EPW	-----	27
PR	-----	28

#### Lifting magnets

PLM	-----	29
PLM-T	-----	30
PLM-R	-----	31
PHS / PVS	-----	32

#### Control unit

CUA / CUD / CUT	-----	33
CGA / CGD	-----	34
CU / CG / RMC	-----	35
CEB / CED	-----	36

# Driven by magnetics

Soph offers the most comprehensive package of magnetic solutions for workholding, mold and die clamping and material handling. Starting the business in 1998, until now Soph owns the trademarks and business of Brisc, Magbo and Helmholtz which is for workholding, mold and die clamping and material handling respectively. Based in Hamburg Germany, after years of development, Soph now has branches in USA and China.

By installing one of the largest finished product inventories and training highly skilled service and sales engineers, Soph has created a substantial reference base in Europe, North America and Far east in a relatively short time. Our ability to provide immediate technical answers, immediate service, custom design, OEM specific products and product lines keeps us ahead of the curve.

With creative problem solving and application specific solutions, Soph is considered to be one of the finest sources for magnetic solutions available. We are dedicated to provide the best product with the best performance to match each application. By using customer input we are able to provide tailor made solutions using standardized products to create unmatched value in substantially shorter market cycles.

Products	Permanent	Electro	Electro-permanent
Applications			
Grinding	PMF / PMT / PMY NY	EMA / EME / EMV	EPB / EPS / EPA EPY
Pallet	PPA / PPC / PPM		PPN
Milling	PMM		PSP / PRP / PZP PCC
EDM	PFD / MBF / NF PMB / PMG		
Turning	NR		EPW / PR
Lifting	PLM / PLM-T / PLM-R		



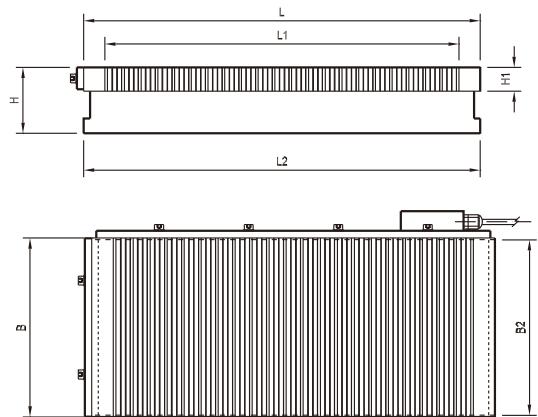

### • Finepitch electromagnetic chuck

#### Use:

For versatile clamping on a broad range of workpiece sizes

#### Features:

- Pole pitch 5+0.5+5+0.5+5+3 mm
- Highest uniform clamping force up to 140 N/cm<sup>2</sup>
- Less than 5°C chuck temperature rise after 1 hour working
- Mono-block housing for maximum stability
- Low current with minimum power consumption
- Low profile for more wheel head clearance
- Versatile clamping, excellent holding on a broad range of workpiece size



Model	Width(B)	Length(L)	Base Width(B2)	Base Length	Height(H)	L1	H1	Voltage	Current	Net Weight
EMA-3060	300 (11.82)	600 (23.62)	294 (11.57)	600 (23.62)	80 (3.15)	554 (21.81)	27 (1.06)	110 V	0.78 A	107kg/236lb
EMA-3080	300 (11.82)	800 (31.50)	294 (11.57)	800 (31.50)	80 (3.15)	744 (29.29)	27 (1.06)	110 V	1 A	143kg/315lb
EMA-30100	300 (11.82)	1000 (39.37)	294 (11.57)	1000 (39.37)	80 (3.15)	934 (36.77)	27 (1.06)	110 V	1.2 A	170kg/375lb
EMA-30120	300 (11.82)	1200 (47.24)	294 (11.57)	1200 (47.24)	80 (3.15)	1124 (44.25)	27 (1.06)	110 V	1.6 A	206kg/454lb
EMA-30150	300 (11.82)	1500 (59.06)	294 (11.57)	1500 (59.06)	80 (3.15)	1428 (56.22)	27 (1.06)	110 V	2.1 A	238kg/525lb
EMA-4060	400 (15.75)	600 (23.62)	394 (15.51)	600 (23.62)	80 (3.15)	554 (21.81)	27 (1.06)	110 V	1.2 A	138kg/304lb
EMA-4080	400 (15.75)	800 (31.50)	394 (15.51)	800 (31.50)	80 (3.15)	744 (29.29)	27 (1.06)	110 V	1.4 A	185kg/408lb
EMA-40100	400 (15.75)	1000 (39.37)	394 (15.51)	1000 (39.37)	80 (3.15)	934 (36.77)	27 (1.06)	110 V	1.9 A	230kg/507lb
EMA-40120	400 (15.75)	1200 (47.24)	394 (15.51)	1200 (47.24)	80 (3.15)	1124 (44.25)	27 (1.06)	110 V	2.2 A	276kg/608lb
EMA-40150	400 (15.75)	1500 (59.06)	394 (15.51)	1500 (59.06)	80 (3.15)	1428 (56.22)	27 (1.06)	110 V	2.5 A	350kg/771lb
EMA-40200	400 (15.75)	1000 (39.37)*2	394 (15.51)	1000 (39.37)*2	80 (3.15)	934 (36.22)*2	27 (1.06)	110 V	1.9 A*2	460kg/1014lb
EMA-5060	500 (19.69)	600 (23.62)	494 (19.45)	600 (23.62)	80 (3.15)	554 (21.81)	27 (1.06)	110 V	1.2 A	170kg/375lb
EMA-5080	500 (19.69)	800 (31.50)	494 (19.45)	800 (31.50)	80 (3.15)	744 (29.29)	27 (1.06)	110 V	1.5 A	212kg/466lb
EMA-50100	500 (19.69)	1000 (39.37)	494 (19.45)	1000 (39.37)	80 (3.15)	934 (36.77)	27 (1.06)	110 V	1.7 A	265kg/583lb
EMA-50120	500 (19.69)	1200 (47.24)	494 (19.45)	1200 (47.24)	80 (3.15)	1124 (44.25)	27 (1.06)	110 V	1.9 A	318kg/699lb
EMA-50150	500 (19.69)	1500 (59.06)	494 (19.45)	1500 (59.06)	80 (3.15)	1428 (56.22)	27 (1.06)	110 V	2.6 A	397kg/874lb
EMA-50200	500 (19.69)	1000 (39.37)*2	494 (19.45)	1000 (39.37)*2	80 (3.15)	934 (36.22)*2	27 (1.06)	110 V	1.7 A*2	530kg/1166lb
EMA-6080	600 (23.62)	800 (31.50)	594 (23.39)	800 (31.50)	85 (3.35)	744 (29.29)	27 (1.06)	110 V	1.5 A	254kg/560lb
EMA-60100	600 (23.62)	1000 (39.37)	594 (23.39)	1000 (39.37)	85 (3.35)	934 (36.77)	27 (1.06)	110 V	2.2 A	318kg/699lb
EMA-60120	600 (23.62)	1200 (47.24)	594 (23.39)	1200 (47.24)	85 (3.35)	1124 (44.25)	27 (1.06)	110 V	2.4 A	382kg/839lb
EMA-60150	600 (23.62)	1500 (59.06)	594 (23.39)	1500 (59.06)	85 (3.35)	1428 (56.22)	27 (1.06)	110 V	2.4 A	477kg/1049lb
EMA-60200	600 (23.62)	1000 (39.37)*2	594 (23.39)	1000 (39.37)*2	85 (3.35)	934 (36.22)*2	27 (1.06)	110 V	2.2 A*2	636kg/1398lb
EMA-70150	700 (27.56)	1500 (59.06)	694 (27.32)	1500 (59.06)	85 (3.35)	1428 (56.22)	27 (1.06)	110 V	2.4 A	556kg/1224lb
EMA-80200	800 (31.50)	1000 (39.37)*2	794 (31.25)	1000 (39.37)*2	85 (3.35)	934 (36.22)*2	27 (1.06)	110 V	2.9 A*2	848kg/1866lb
EMA-100150	1000 (39.37)	1500 (59.06)	994 (39.13)	1500 (59.06)	85 (3.35)	1428 (56.22)	27 (1.06)	110 V	5 A*2	848kg/1866lb
EMA-100200	1000 (39.37)	1000 (39.37)*2	994 (39.13)	1000 (39.37)*2	85 (3.35)	934 (36.22)*2	27 (1.06)	110 V	3.3 A*2	1130kg/2487lb
EMA-120200	1200 (47.24)	1000 (39.37)*2	1194 (47.01)	1000 (39.37)*2	85 (3.35)	934 (36.22)*2	27 (1.06)	110 V	4 A*2	1356kg/2984lb
EMA-120300	1200 (47.24)	1000 (39.37)*3	1194 (47.01)	1000 (39.37)*3	85 (3.35)	934 (36.22)*3	27 (1.06)	110 V	4 A*3	2035kg/4476lb
EMA-150300	1500 (59.06)	1000 (39.37)*3	1494 (52.82)	1000 (39.37)*3	85 (3.35)	934 (36.22)*3	27 (1.06)	110 V	6.5 A*3	2543kg/5595lb
EMA-150500	1500 (59.06)	1000 (39.37)*5	1492 (52.82)	1000 (39.37)*5	85 (3.35)	934 (36.22)*5	27 (1.06)	110 V	6.5 A*5	2852kg/6287lb

Unit: mm(in)

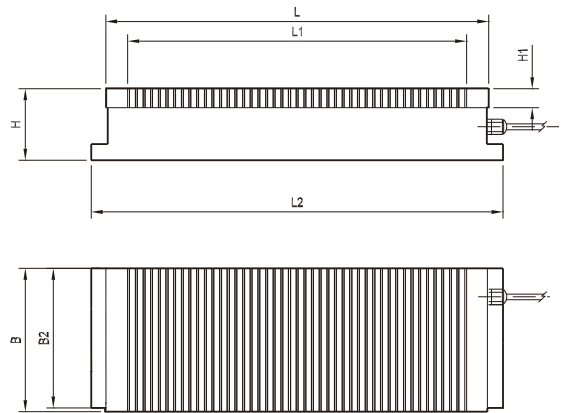

### • Micropitch electromagnetic chuck with transverse poles

#### Use:

Clamping of transverse placed thin plate shaped workpieces

#### Features:

- EME with pole pitch 0.5+1.5 mm
- Highest uniform clamping force up to 120 N/cm<sup>2</sup>
- Top plate with micropitch transverse lamination
- Flux depth of only 4 mm
- Mono-block housing for maximum stability



Model	Width	Length	Base Width	Base Length	Height	L1	H1	Voltage	Current	Net Weight
EME-1525	150 (5.91)	250 (9.85)	148 (5.83)	270 (10.63)	75 (2.95)	214 (8.43)	20 (0.79)	110 V	0.72 A	19 kg / 42 lb
EME-1530	150 (5.91)	300 (11.82)	148 (5.83)	320 (12.60)	75 (2.95)	264 (10.40)	20 (0.79)	110 V	0.62 A	23 kg / 51 lb
EME-1535	150 (5.91)	350 (13.79)	148 (5.83)	370 (11.57)	75 (2.95)	314 (12.37)	20 (0.79)	110 V	0.80 A	27 kg / 59 lb
EME-1540	150 (5.91)	400 (15.76)	148 (5.83)	420 (16.54)	75 (2.95)	364 (14.34)	20 (0.79)	110 V	0.70 A	31 kg / 68 lb
EME-1545	150 (5.91)	450 (17.73)	148 (5.83)	470 (18.50)	75 (2.95)	414 (16.31)	20 (0.79)	110 V	1.00 A	34 kg / 75 lb
EME-1840	180 (7.09)	400 (15.76)	178 (7.01)	420 (16.54)	75 (2.95)	364 (14.34)	20 (0.79)	110 V	0.94 A	37 kg / 81 lb
EME-2040	200 (7.88)	400 (15.76)	198 (7.80)	420 (16.54)	75 (2.95)	364 (14.34)	20 (0.79)	110 V	1.00 A	41 kg / 90 lb
EME-2045	200 (7.88)	450 (17.73)	198 (7.80)	470 (18.50)	75 (2.95)	414 (16.31)	20 (0.79)	110 V	1.10 A	46 kg / 101 lb
EME-2050	200 (7.88)	500 (19.70)	198 (7.80)	520 (20.47)	75 (2.95)	440 (17.34)	20 (0.79)	110 V	1.30 A	51 kg / 112 lb
EME-2060	200 (7.88)	600 (23.64)	198 (7.80)	620 (24.41)	75 (2.95)	554 (21.83)	20 (0.79)	110 V	1.10 A	61 kg / 134 lb
EME-2550	250 (9.85)	500 (19.70)	248 (9.77)	520 (20.47)	75 (2.95)	440 (17.34)	20 (0.79)	110 V	1.70 A	64 kg / 141 lb
EME-2560	250 (9.85)	600 (23.64)	248 (9.77)	620 (24.41)	75 (2.95)	554 (21.83)	20 (0.79)	110 V	1.90 A	77 kg / 169 lb
EME-3060	300 (11.82)	600 (23.64)	298 (11.74)	620 (24.41)	75 (2.95)	554 (21.83)	20 (0.79)	110 V	1.90 A	94 kg / 207 lb
EME-4080	400 (15.76)	800 (31.52)	398 (15.68)	820 (32.28)	75 (2.95)	745 (29.33)	20 (0.79)	110 V	2.80 A	171 kg / 376 lb
EME-5080	500 (19.70)	800 (31.52)	498 (19.62)	820 (32.28)	75 (2.95)	745 (29.33)	20 (0.79)	110 V	3.20 A	210 kg / 462 lb

Unit: mm(in)

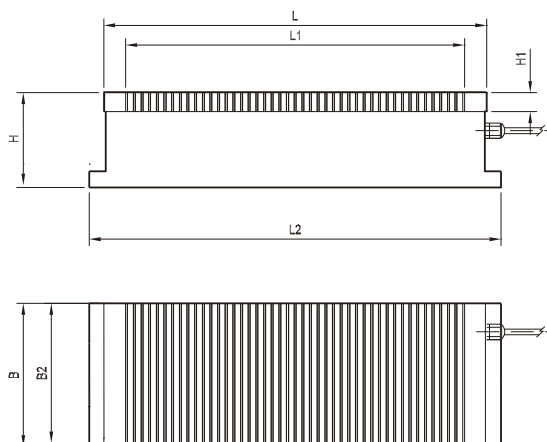

### • Micropitch electromagnetic chuck with transverse poles

#### Use:

Clamping of transverse placed thin plate shaped workpieces

#### Features:

- EMV with pole pitch 0.5+1.5 mm
- Highest uniform clamping force up to 120 N/cm<sup>2</sup>
- Top plate with micropitch transverse lamination
- Flux depth of only 4 mm
- Mono-block housing for maximum stability
- Low current with minimum power consumption



Model	Width	Length	Base Width	Base Length	Height	L1	H1	Voltage	Current	Net Weight
EMV-1525	150 (5.91)	250 (9.85)	148 (5.83)	270 (10.63)	110 (4.33)	214 (8.43)	20 (0.79)	110 V	0.40 A	30 kg / 66 lb
EMV-1530	150 (5.91)	300 (11.82)	148 (5.83)	320 (12.60)	110 (4.33)	264 (10.40)	20 (0.79)	110 V	0.36 A	36 kg / 79 lb
EMV-1535	150 (5.91)	350 (13.79)	148 (5.83)	370 (11.57)	110 (4.33)	314 (12.37)	20 (0.79)	110 V	0.48 A	42 kg / 92 lb
EMV-1540	150 (5.91)	400 (15.76)	148 (5.83)	420 (16.54)	110 (4.33)	364 (14.34)	20 (0.79)	110 V	0.42 A	52 kg / 114 lb
EMV-1545	150 (5.91)	450 (17.73)	148 (5.83)	470 (18.50)	110 (4.33)	414 (16.31)	20 (0.79)	110 V	0.60 A	55 kg / 121 lb
EMV-1840	180 (7.09)	400 (15.76)	178 (7.01)	420 (16.54)	110 (4.33)	364 (14.34)	20 (0.79)	110 V	0.55 A	58 kg / 127 lb
EMV-2040	200 (7.88)	400 (15.76)	198 (7.80)	420 (16.54)	110 (4.33)	364 (14.34)	20 (0.79)	110 V	0.60 A	66 kg / 145 lb
EMV-2045	200 (7.88)	450 (17.73)	198 (7.80)	470 (18.50)	110 (4.33)	414 (16.31)	20 (0.79)	110 V	0.66 A	76 kg / 167 lb
EMV-2050	200 (7.88)	500 (19.70)	198 (7.80)	520 (20.47)	110 (4.33)	440 (17.34)	20 (0.79)	110 V	0.78 A	82 kg / 180 lb
EMV-2060	200 (7.88)	600 (23.64)	198 (7.80)	620 (24.41)	110 (4.33)	554 (21.83)	20 (0.79)	110 V	0.66 A	98 kg / 216 lb
EMV-2550	250 (9.85)	500 (19.70)	248 (9.77)	520 (20.47)	110 (4.33)	440 (17.34)	20 (0.79)	110 V	1.00 A	102 kg / 224 lb
EMV-2560	250 (9.85)	600 (23.64)	248 (9.77)	620 (24.41)	110 (4.33)	554 (21.83)	20 (0.79)	110 V	1.14 A	123 kg / 271 lb
EMV-3060	300 (11.82)	600 (23.64)	298 (11.74)	620 (24.41)	110 (4.33)	554 (21.83)	20 (0.79)	110 V	1.14 A	156 kg / 343 lb
EMV-4080	400 (15.76)	800 (31.52)	398 (15.68)	820 (32.28)	110 (4.33)	745 (29.33)	20 (0.79)	110 V	1.70 A	262 kg / 577 lb
EMV-5080	500 (19.70)	800 (31.52)	498 (19.62)	820 (32.28)	110 (4.33)	745 (29.33)	20 (0.79)	110 V	1.90 A	328 kg / 723 lb

Unit: mm(in)

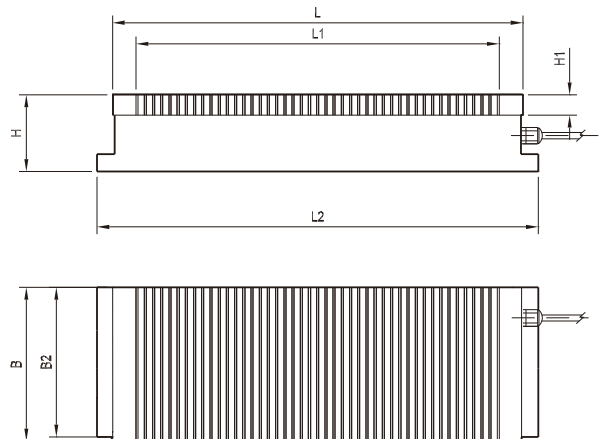

Grinding

**• Micropitch electro-permanent magnetic chuck with transverse poles**

**Use:**

Clamping of transverse placed thin plate shaped workpieces

**Features:**

- EPB with pole pitch 1+3 mm
- Highest uniform clamping force up to 120 N/cm<sup>2</sup>
- Electro-permanent technology with no deformation owing to the rise of temperature
- Can eliminate residual magnetism from the workpiece
- Coolant and water proof structure
- Minimum mechanical deformation with solid one-piece housing

Model	Width(B)	Length(L)	Base Width(B2)	Height(H)	L1	H1	Net Weight	Controller (400V)	Controller (220V)
EPB-1525	150 (5.91)	250 (9.85)	148 (5.83)	75 (2.95)	214 (8.43)	20 (0.79)	21 kg / 46 lb	CGA	CGA
EPB-1530	150 (5.91)	300 (11.82)	148 (5.83)	75 (2.95)	264 (10.40)	20 (0.79)	25 kg / 55 lb	CGA	CGA
EPB-1535	150 (5.91)	350 (13.79)	148 (5.83)	75 (2.95)	314 (12.37)	20 (0.79)	29 kg / 64 lb	CGA	CGA
EPB-1540	150 (5.91)	400 (15.76)	148 (5.83)	75 (2.95)	364 (14.34)	20 (0.79)	36 kg / 79 lb	CGA	CGA
EPB-1545	150 (5.91)	450 (17.73)	148 (5.83)	75 (2.95)	414 (16.31)	20 (0.79)	38 kg / 84 lb	CGA	CGA
EPB-1840	180 (7.09)	400 (15.76)	178 (7.01)	75 (2.95)	364 (14.34)	20 (0.79)	40 kg / 88 lb	CGA	CGA
EPB-2040	200 (7.88)	400 (15.76)	198 (7.80)	75 (2.95)	364 (14.34)	20 (0.79)	45 kg / 99 lb	CGA	CGA
EPB-2045	200 (7.88)	450 (17.73)	198 (7.80)	75 (2.95)	414 (16.31)	20 (0.79)	52 kg / 114 lb	CGA	CGA
EPB-2050	200 (7.88)	500 (19.70)	198 (7.80)	75 (2.95)	464 (18.27)	20 (0.79)	56 kg / 123 lb	CGA	CGA
EPB-2060	200 (7.88)	600 (23.64)	198 (7.80)	75 (2.95)	564 (22.20)	20 (0.79)	67 kg / 148 lb	CGA	CGA
EPB-2550	250 (9.85)	500 (19.70)	248 (9.77)	75 (2.95)	464 (18.27)	20 (0.79)	70 kg / 154 lb	CGA	CGA
EPB-2560	250 (9.85)	600 (23.64)	248 (9.77)	75 (2.95)	564 (22.20)	20 (0.79)	84 kg / 185 lb	CGA	CGA
EPB-3060	300 (11.82)	600 (23.64)	298 (11.74)	75 (2.95)	564 (22.20)	20 (0.79)	107 kg / 236 lb	CGA	CGA
EPB-3080	300 (11.82)	800 (31.52)	298 (11.74)	75 (2.95)	764 (30.08)	20 (0.79)	143 kg / 315 lb	CGA	CGA
EPB-30100	300 (11.82)	1000 (39.40)	298 (11.74)	75 (2.95)	964 (37.95)	20 (0.79)	170 kg / 375 lb	CGA	CGA
EPB-30120	300 (11.82)	1200 (47.28)	298 (11.74)	75 (2.95)	1164 (45.83)	20 (0.79)	206 kg / 454 lb	CGA	CGA
EPB-4060	400 (15.76)	600 (23.64)	398 (15.68)	75 (2.95)	564 (22.20)	20 (0.79)	134 kg / 295 lb	CGA	CGA
EPB-4080	400 (15.76)	800 (31.52)	398 (15.68)	75 (2.95)	764 (30.08)	20 (0.79)	238 kg / 525 lb	CGA	CGA

Unit: mm(in)





• Square pole electro-permanent magnetic chuck with standard density

**Use:**

Clamping for grinding of medium to large work pieces

**Features:**

- Full metallic surface, no resin, coolant and water proof
- Square pole size 50x50 mm
- Magnetic force higher than 200 kg per pole
- Electro-permanent magnetic technology with no deformation owing to the rise of temperature
- Distortion free clamping with auto-shim pole extensions
- No residual magnetism
- Workpiece larger than the table size are possible
- Multiple magnet combinations can provide clamping for larger sizes
- Magnetic flux depth 12.5 mm



ES-5052

**Fix pole extensions**

ES fixed and ET self shimming pole extensions using the built in threaded rod which does not require tools to install or remove.



ET-5052

**Mobile pole extensions**

The new and improved ET pole extension has increased the performance of the original ET by 20%. Total adjustment is 6 mm.

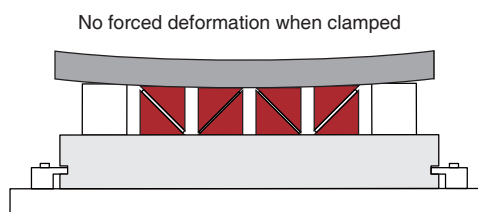
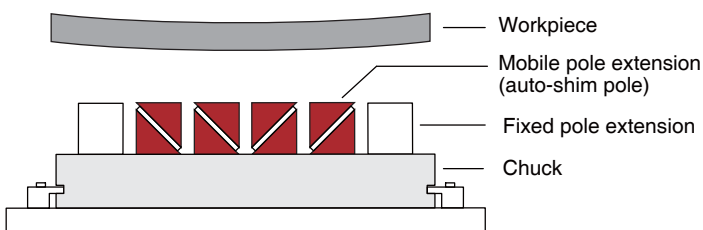

Model	Width	Length	Height	Pole No.	Controller (400/480V)	Controller (220V)	Net Weight
EPS-3049	300 (11.82)	490 (19.29)	59 (2.32)	24	CGA	CGA	75 kg / 165 lb
EPS-3064	300 (11.82)	640 (25.20)	59 (2.32)	32	CGA	CGA	98 kg / 216 lb
EPS-3649	360 (14.17)	490 (19.29)	59 (2.32)	30	CGA	CGA	78 kg / 172 lb
EPS-3664	360 (14.17)	640 (25.20)	59 (2.32)	40	CGA	CGA	101 kg / 222 lb
EPS-3679	360 (14.17)	790 (31.10)	59 (2.32)	50	CGA	CGA	125 kg / 276 lb
EPS-4279	420 (16.54)	790 (31.10)	59 (2.32)	60	CGA	CGD	146 kg / 322 lb
EPS-4894	480 (18.90)	940 (37.00)	59 (2.32)	84	CGA	CGD	199 kg / 439 lb
EPS-48109	480 (18.90)	1090 (42.91)	59 (2.32)	98	CGD	CGD	230 kg / 507 lb
EPS-5494	540 (21.26)	940 (37.00)	59 (2.32)	96	CGD	CGD	258 kg / 569 lb
EPS-54109	540 (21.26)	1090 (42.91)	59 (2.32)	112	CGD	CGD	300 kg / 661 lb
EPS-60139	600 (23.62)	1390 (54.72)	59 (2.32)	162	CGD	CGF	367 kg / 809 lb
EPS-60154	600 (23.62)	1540 (60.63)	59 (2.32)	180	CGF	CGF	407 kg / 897lb
EPS-66139	660 (25.98)	1390 (54.72)	59 (2.32)	170	CGF	CGF	404 kg / 899lb
EPS-66154	660 (25.98)	1540 (60.63)	59 (2.32)	188	CGF	CGF	450 kg / 992lb

Unit: mm(in)



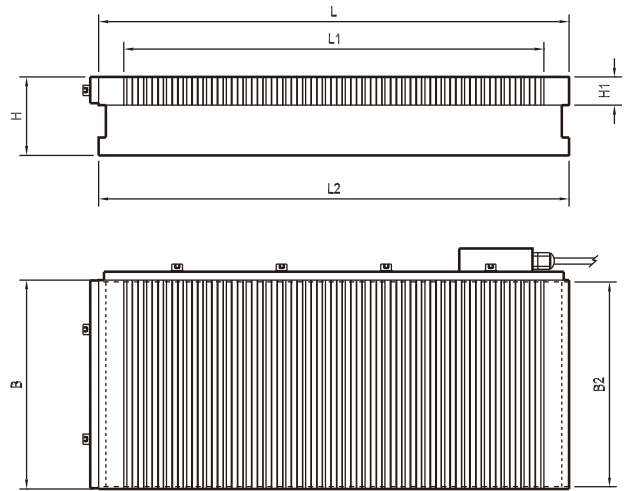

Grinding

### ● Finepitch electro-permanent magnetic chuck

#### Use:

For versatile clamping on a broad range of workpiece sizes

#### Features:

- Pole pitch 5+0.5+5+0.5+5+3 mm
- Highest uniform clamping force up to 140 N/cm<sup>2</sup>
- Electro-permanent magnetic technology with no deformation owing to the rise of temperature
- Can eliminate residual magnetism from the workpiece
- Coolant and water proof structure
- Mono-block housing for maximum stability



Model	Width(B)	Length(L)	Base Width(B2)	Height(H)	L1	H1	Net Weight	Controller (400V)
EPA-50100	500 (19.70)	1000 (39.40)	498 (19.62)	75 (2.95)	934 (36.77)	27 (1.06)	265 kg / 583 lb	CGA
EPA-50120	500 (19.70)	1200 (47.28)	498 (19.62)	75 (2.95)	1124 (44.25)	27 (1.06)	318 kg / 699 lb	CGA
EPA-50150	500 (19.70)	1500 (59.10)	498 (19.62)	75 (2.95)	1428 (56.22)	27 (1.06)	397 kg / 874 lb	CGD
EPA-50200	500 (19.70)	1000 (39.37)*2	498 (19.62)	75 (2.95)	934 (36.77)	27 (1.06)	530 kg / 1166 lb	CGD
EPA-6080	600 (23.64)	800 (31.52)	598 (23.56)	75 (2.95)	744 (30.47)	27 (1.06)	254 kg / 560 lb	CGA
EPA-60100	600 (23.64)	1000 (39.40)	598 (23.56)	75 (2.95)	934 (36.77)	27 (1.06)	318 kg / 699 lb	CGD
EPA-60120	600 (23.64)	1200 (47.28)	598 (23.56)	75 (2.95)	1124 (44.25)	27 (1.06)	382 kg / 839 lb	CGD
EPA-60150	600 (23.64)	1500 (59.10)	598 (23.56)	75 (2.95)	1428 (56.22)	27 (1.06)	477 kg / 1049 lb	CGD
EPA-60200	600 (23.64)	1000 (39.37)*2	598 (23.56)	75 (2.95)	934 (36.77)	27 (1.06)	636 kg / 1398 lb	CGF
EPA-60220	600 (23.64)	1100 (43.30)*2	598 (23.56)	75 (2.95)	1048 (41.26)	27 (1.06)	740 kg / 1631 lb	CGF
EPA-60250	600 (23.64)	1250 (49.21)*2	598 (23.56)	75 (2.95)	1184 (46.61)	27 (1.06)	841 kg / 1854 lb	CGF
EPA-70150	700 (27.58)	1500 (59.10)	698 (27.50)	75 (2.95)	1428 (56.22)	27 (1.06)	477 kg / 1049 lb	CGF
EPA-75150	750 (29.55)	1500 (59.10)	748 (29.47)	75 (2.95)	1428 (56.22)	27 (1.06)	631 kg / 1391 lb	CGF

Unit: mm(in)

## PMF

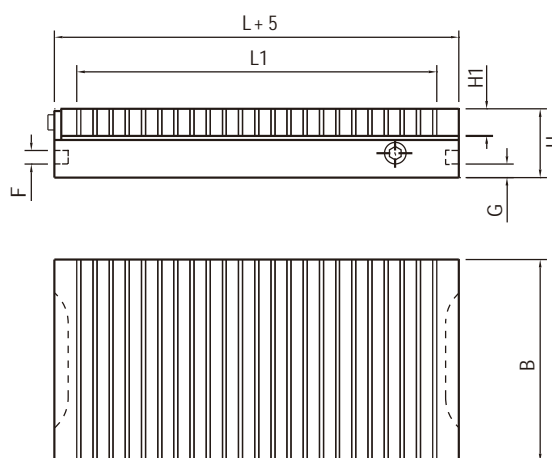

### • Permanent magnetic chuck

#### Use:

General purpose low profile grinding magnet

#### Features:

- PMF with pole pitch 0.5+1.5 mm
- Highest uniform magnetic clamping force up to 120 N/cm<sup>2</sup>
- Coolant and water proof structure
- Easy to activate and de-activate
- High precision with no residual magnetism



Model	Width(B)	Length(L)	Height(H)	L1	H1	F	G	Net Weight
PMF-0713	70 (2.76)	130 (5.12)	49 (1.93)	101 (3.98)	20 (0.79)	10 (0.39)	10 (0.39)	3 kg / 8 lb
PMF-10175	100 (3.94)	175 (6.90)	49 (1.93)	140 (5.51)	20 (0.79)	10 (0.39)	10 (0.39)	7 kg / 15 lb
PMF-1025	100 (3.94)	250 (9.84)	49 (1.93)	206 (8.11)	20 (0.79)	10 (0.39)	10 (0.39)	10 kg / 21 lb
PMF-1325	130 (5.12)	255 (10.03)	49 (1.93)	206 (8.11)	20 (0.79)	10 (0.39)	10 (0.39)	12 kg / 27 lb
PMF-1340	130 (5.12)	400 (15.75)	49 (1.93)	357 (14.06)	20 (0.79)	10 (0.39)	10 (0.39)	20 kg / 44 lb
PMF-1426	140 (5.52)	260 (10.24)	51 (2.01)	216 (8.50)	20 (0.79)	10 (0.39)	10 (0.39)	14 kg / 32 lb
PMF-1515	150 (5.90)	150 (5.91)	51 (2.02)	108 (4.25)	20 (0.79)	10 (0.39)	10 (0.39)	9 kg / 20 lb
PMF-1525	150 (5.91)	250 (9.84)	51 (2.01)	206 (8.11)	20 (0.79)	10 (0.39)	10 (0.39)	15 kg / 33 lb
PMF-1530	150 (5.91)	300 (11.81)	51 (2.01)	257 (10.12)	20 (0.79)	10 (0.39)	10 (0.39)	18 kg / 39 lb
PMF-1535	150 (5.91)	350 (13.78)	51 (2.01)	305 (12.01)	20 (0.79)	10 (0.39)	10 (0.39)	21 kg / 46 lb
PMF-1540	150 (5.91)	400 (15.75)	51 (2.01)	357 (14.06)	20 (0.79)	10 (0.39)	10 (0.39)	24 kg / 53 lb
PMF-1545	150 (5.91)	450 (17.72)	51 (2.01)	407 (17.34)	20 (0.79)	10 (0.39)	10 (0.39)	27 kg / 59 lb
PMF-2030	200 (7.88)	300 (11.81)	51 (2.01)	257 (10.12)	20 (0.79)	10 (0.39)	10 (0.39)	24 kg / 53 lb
PMF-2035	200 (7.88)	350 (13.78)	51 (2.01)	305 (12.01)	20 (0.79)	10 (0.39)	10 (0.39)	28 kg / 61 lb
PMF-2040	200 (7.88)	400 (15.75)	51 (2.01)	357 (14.06)	20 (0.79)	10 (0.39)	10 (0.39)	32 kg / 70 lb
PMF-2045	200 (7.88)	450 (17.72)	51 (2.01)	407 (17.34)	20 (0.79)	10 (0.39)	10 (0.39)	36 kg / 79 lb
PMF-2050	200 (7.88)	500 (19.69)	51 (2.01)	454 (17.87)	20 (0.79)	10 (0.39)	10 (0.39)	40 kg / 88 lb
PMF-2060	200 (7.88)	600 (23.62)	51 (2.01)	556 (21.89)	20 (0.79)	10 (0.39)	10 (0.39)	48 kg / 105 lb
PMF-2063	200 (7.88)	630 (24.80)	51 (2.01)	586 (23.07)	20 (0.79)	10 (0.39)	10 (0.39)	50 kg / 110 lb
PMF-2535	250 (9.85)	350 (13.79)	56 (2.20)	305 (12.01)	22 (0.87)	10 (0.39)	10 (0.39)	38 kg / 84 lb
PMF-2540	250 (9.85)	400 (15.76)	56 (2.20)	357 (14.06)	23 (0.87)	10 (0.39)	10 (0.39)	44 kg / 96 lb
PMF-2550	250 (9.85)	500 (19.70)	56 (2.20)	454 (17.87)	24 (0.87)	10 (0.39)	10 (0.39)	55 kg / 120 lb
PMF-2563	250 (9.85)	630 (24.82)	56 (2.20)	586 (23.07)	25 (0.87)	10 (0.39)	10 (0.39)	69 kg / 151 lb
PMF-3030	300 (11.82)	300 (11.82)	56 (2.20)	257 (10.12)	26 (0.87)	10 (0.39)	10 (0.39)	36 kg / 79 lb
PMF-3040	300 (11.82)	400 (15.76)	56 (2.20)	357 (14.06)	27 (0.87)	10 (0.39)	10 (0.39)	52 kg / 115 lb
PMF-3050	300 (11.82)	500 (19.70)	56 (2.20)	454 (17.87)	28 (0.87)	10 (0.39)	10 (0.39)	66 kg / 144 lb
PMF-3060	300 (11.82)	600 (23.64)	56 (2.20)	556 (21.89)	29 (0.87)	10 (0.39)	10 (0.39)	79 kg / 173 lb
PMF-3063	300 (11.82)	630 (24.82)	56 (2.20)	586 (23.07)	30 (0.87)	10 (0.39)	10 (0.39)	83 kg / 182 lb
PMF-4060	400 (15.76)	600 (23.64)	56 (2.20)	556 (21.89)	31 (0.87)	10 (0.39)	10 (0.39)	106 kg / 233 lb

Unit: mm(in)

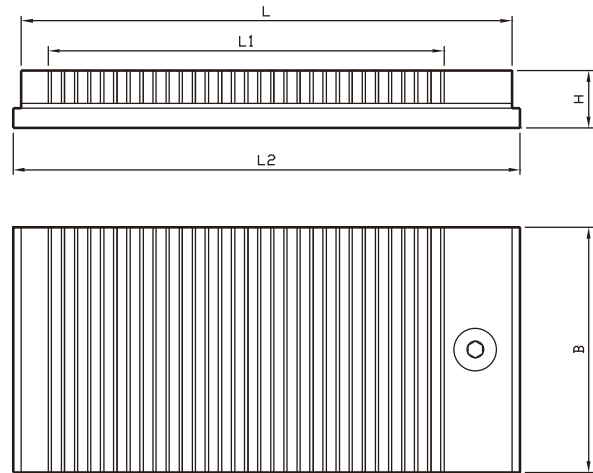

**• Permanent magnetic low profile chuck**

**Use:**

For spark erosion and precision grinding of small and thin workpieces

**Features:**

- Pole pitch 0.5+1.5 mm
- Max. magnetic clamping force up to 120 N/cm<sup>2</sup>
- Low profile with activation from top surface
- Suitable for adaption on zero reference system
- Low flux depth of 6mm and no residual magnetism
- EDM can be performed close to surface without magnetic interference

Model	Width(B)	Length(L)	Base Length(L2)	Height(H)	L1	Net Weight
PMT-0713	70 (2.76)	130 (5.12)	140 (5.51)	32 (1.26)	67(2.64)	4 kg / 9 lb
PMT-10175	100 (3.94)	175 (6.89)	185 (7.28)	32 (1.26)	117(4.61)	5 kg / 11 lb
PMT-1325	130 (5.12)	250 (9.84)	260 (10.24)	35 (1.38)	192 (7.56)	9 kg / 20 lb
PMT-1515	150 (5.91)	150 (5.91)	160 (6.30)	35 (1.38)	92(3.62)	6 kg / 13 lb
PMT-1525	150 (5.91)	250 (9.84)	260 (10.24)	35 (1.38)	192 (7.56)	10 kg / 22 lb
PMT-1530	150 (5.91)	300 (11.81)	310 (12.20)	35 (1.38)	242 (9.53)	12 kg / 26 lb
PMT-1535	150 (5.91)	350 (13.78)	360 (14.17)	35 (1.38)	292 (11.50)	14 kg / 31 lb
PMT-1545	150 (5.91)	450 (17.72)	460 (18.11)	35 (1.38)	392 (15.43)	18 kg / 40 lb
PMT-2030	200 (7.87)	300 (11.81)	310 (12.20)	35 (1.38)	242 (9.53)	16 kg / 35 lb
PMT-2040	200 (7.87)	400 (15.75)	410 (16.14)	35 (1.38)	342 (13.46)	23 kg / 51lb
PMT-2050	200 (7.87)	500 (19.69)	510 (20.08)	35 (1.38)	442 (17.40)	27 kg / 59 lb
PMT-2535	250 (9.84)	350 (13.78)	360 (14.17)	35 (1.38)	292 (11.50)	24 kg / 53 lb
PMT-3030	300 (11.81)	300 (11.81)	310 (12.20)	35 (1.38)	242 (9.53)	24 kg / 53 lb
PMT-3040	300 (11.81)	400 (15.75)	410 (16.14)	35 (1.38)	342 (13.46)	32 kg / 70 lb

Unit: mm(in)

## PMY

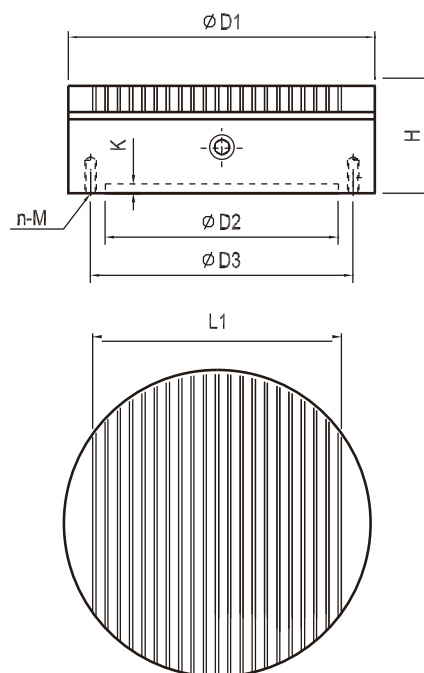

● **Circular permanent magnetic chuck with micropitch poles**

**Use:**

Clamping for grinding

**Features:**

- PMY with pole pitch 0.5+1.5 mm
- Max. uniform magnetic clamping force up to 120 N/cm<sup>2</sup>
- Best for small and thin workpiece
- Low height and light weight
- High precision with no residual magnetism

Model	Diameter(D)	Height	L1	D2	D3	n	M	K	Net Weight
PMY-100	100 (3.94)	50 (1.97)	76.5 (3.01)	60 (2.36)	85 (3.35)	4	8	4 (0.16)	3 kg / 7 lb
PMY-130	130 (5.12)	50 (1.97)	100 (3.94)	90 (3.54)	115 (4.53)	4	8	4 (0.16)	5 kg / 11 lb
PMY-150	150 (5.91)	50 (1.97)	117 (4.61)	110 (4.33)	132 (5.20)	4	8	4 (0.16)	7 kg / 15 lb
PMY-160	160 (6.30)	52 (2.05)	129 (5.08)	120 (4.72)	140 (5.51)	4	10	4 (0.16)	8 kg / 18 lb
PMY-200	200 (7.87)	52 (2.05)	169 (6.65)	160 (6.30)	180 (7.09)	4	10	4 (0.16)	12 kg / 26 lb
PMY-250	250 (9.84)	52 (2.05)	213 (8.39)	200 (7.87)	230 (9.06)	4	10	4 (0.16)	19 kg / 42 lb
PMY-300	300 (11.81)	54 (2.13)	265 (10.43)	250 (9.84)	280 (11.02)	4	12	4 (0.16)	28 kg / 62 lb
PMY-400	400 (15.75)	58 (2.28)	360 (14.17)	320 (12.60)	360 (14.17)	6	12	4 (0.16)	57 kg / 125 lb
PMY-600	600 (23.62)	62 (2.44)	553 (21.77)	500 (19.69)	540 (21.26)	6	12	5 (0.20)	137 kg / 301 lb

Unit: mm(in)

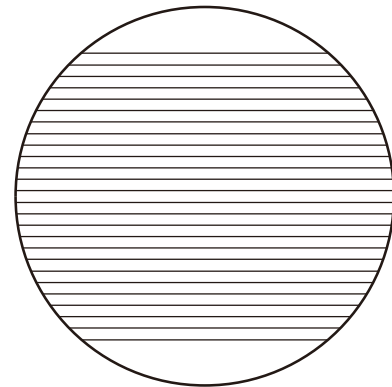
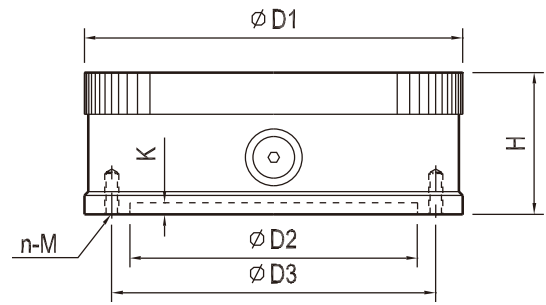

● **Circular permanent magnetic chuck with parallel poles**

**Use:**

Clamping for grinding and turning

**Features:**

- Pole pitch 5+8 mm
- Max. magnetic clamping force up to 140 N/cm<sup>2</sup>
- Concentric grooves simplify the centring of workpiece
- Variable magnetic clamping force
- Balanced for high RPM
- Centre drilling of locating hole is available on request
- High precision with no residual magnetism

Model	Diameter(D1)	Height(H)	D2	D3	n	M	G	K	Net Weight
NY-100	100 (3.94)	60 (2.36)	70 (2.76)	85 (3.35)	4	8	5 (0.16)	5 (0.2)	3.5 kg / 7.7 lb
NY-130	130 (5.12)	60 (2.36)	90 (3.54)	100 (3.94)	4	8	5 (0.16)	5 (0.2)	5.9 kg / 13 lb
NY-150	150 (5.91)	60 (2.36)	110 (4.33)	115 (4.53)	4	8	5 (0.16)	5 (0.2)	8 kg / 224 lb
NY-160	160 (6.30)	60 (2.36)	120 (4.72)	140 (5.51)	4	8	5 (0.16)	5 (0.2)	9 kg / 19.8 lb
NY-200	200 (7.87)	80 (3.15)	150 (6.30)	180 (7.09)	6	8	5 (0.16)	5 (0.2)	13 kg / 29 lb
NY-250	250 (9.84)	80 (3.15)	200 (7.87)	230 (9.06)	6	8	5 (0.16)	5 (0.2)	20 kg / 44 lb
NY-300	300 (11.81)	85 (3.35)	250 (9.84)	280 (11.02)	6	8	5 (0.16)	5 (0.2)	29 kg / 64 lb
NY-350	350 (13.78)	85 (3.35)	300 (11.81)	330 (12.99)	6	12	5 (0.16)	5 (0.2)	40 kg / 88 lb
NY-400	400 (15.75)	85 (3.35)	300 (11.81)	350 (47.24)	6	12	5 (0.16)	5 (0.2)	59 kg / 130 lb
NY-450	450 (17.72)	85 (3.35)	350 (13.78)	400 (59.06)	6	12	5 (0.16)	5 (0.2)	70 kg / 154 lb
NY-500	500 (19.69)	85 (3.35)	400 (15.75)	450 (17.72)	6	12	5 (0.16)	5 (0.2)	90 kg / 198 lb

Unit: mm(in)

## EPY

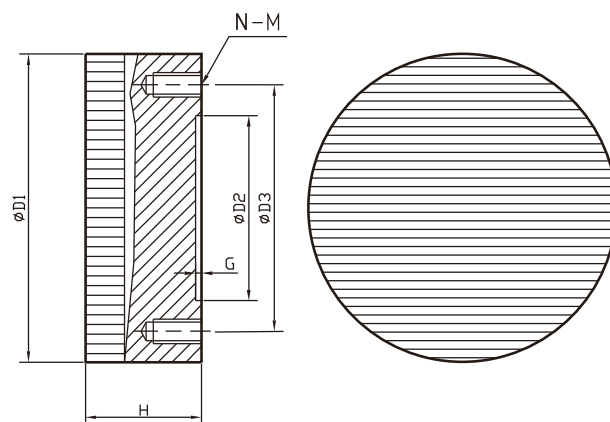

### • Circular electro-permanent magnetic

#### Use:

Clamping for grinding of disc shaped workpieces on internal and external grinders with rotary tables

#### Features:

- Pole pitch 1+3 mm
- Max. magnetic clamping force up to 120 N/cm<sup>2</sup>
- Electro-permanent technology with no deformation owing to the rise of temperature
- Can eliminate residual magnetism from the workpiece
- Coolant and water proof structure
- Mono-block housing for maximum stability

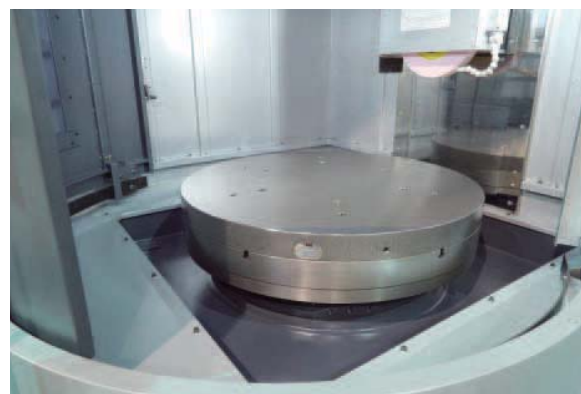

Model	Diameter(D1)	Height(H)	D2	D3	n	M	G	Net Weight	Controller (400V)
EPY-300	300(11.81)	75(2.95)	160(6.30)	190(7.48)	4	10	4 (0.16)	40 kg / 88 lb	CGA
EPY-400	400(11.75)	75(2.95)	210(7.87)	250(9.84)	6	12	4 (0.16)	73 kg / 161 lb	CGA
EPY-500	500(19.69)	75(2.95)	320(12.60)	380(14.96)	6	12	4 (0.16)	115 kg / 254 lb	CGA
EPY-600	600(23.62)	75(2.95)	350(13.78)	390(15.35)	6	12	4 (0.16)	165 kg / 364 lb	CGA
EPY-700	700(27.56)	75(2.95)	400(15.75)	450(17.72)	6	16	4 (0.16)	265 kg / 584 lb	CGD
EPY-800	800(31.50)	75(2.95)	450(17.72)	500(19.69)	6	16	4 (0.16)	295 kg / 650 lb	CGD
EPY-1000	1000(39.37)	75(2.95)	550(21.65)	620(24.41)	8	16	4 (0.16)	460 kg / 1014 lb	CGD
EPY-1200	1200(47.24)	80 (3.15)	Upon request					590 kg / 1298 lb	CGF
EPY-1500	1500(59.06)	80 (3.15)	Upon request					922 kg / 2028 lb	CGF

Unit: mm(in)

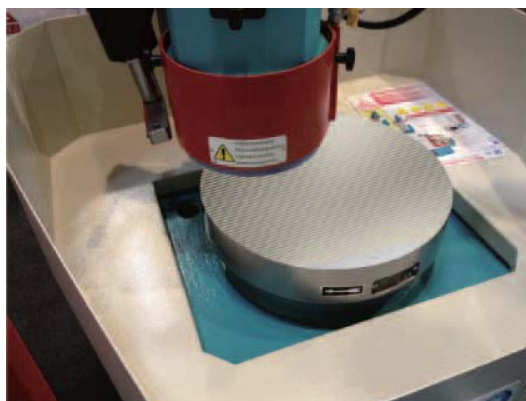

# PPN / PPA

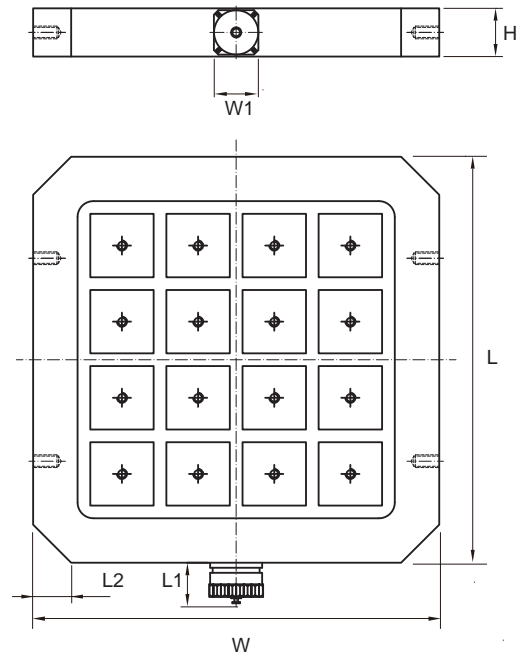

**● Pallet chuck**

**Use:**  
Clamping for heavy machining for medium to large work pieces

- Features:**
- Square pole size 50x50 mm
  - Magnetic force higher than 350 kg per pole
  - Electro-permanent technology with no deformation owing to the rise of temperature
  - Distortion free clamping with auto-shim pole extensions
  - No residual magnetism
  - Controlled flux prevents magnetization of the tool
  - Workpiece larger than the table size are machinable

Model	Width	Length	Height	W1	L1	L2	Net Weight
PPN-3232	320 (12.60)	320 (12.60)	38 (1.50)	35 (1.38)	35 (1.38)	30 (1.18) x 45°	30 kg / 66 lb

Unit: mm(in)

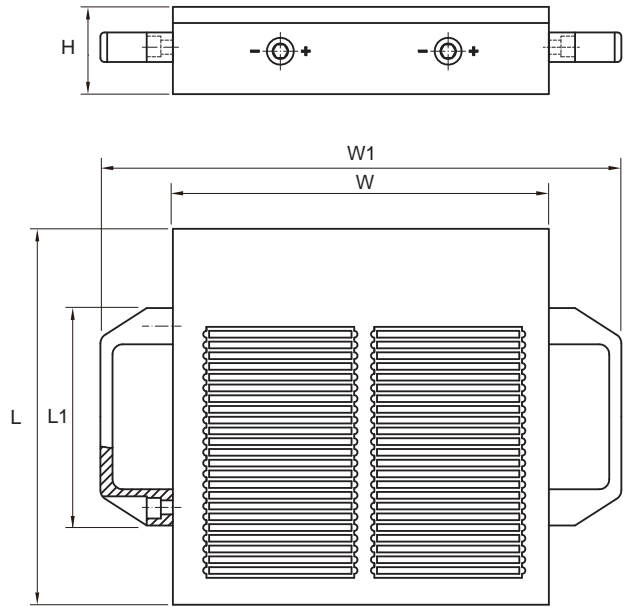

**● Pallet chuck**

**Use:**  
For zero point clamping systems

- Features:**
- Aluminium housing
  - Pole pitch 5+3 mm
  - Two switchable sections
  - Max magnetic clamping force up to 160 N/cm<sup>2</sup>
  - Low magnetic flux

Model	Width	Length	Height	L1	Net Weight
PPA-2424	240 (9.45)	240 (9.45)	65 (2.56)	162 (6.38)	16 kg / 35 lb
PPA-2828	280 (11.02)	280 (11.02)	65 (2.56)	162 (6.38)	20 kg / 44 lb
PPA-3232	320 (12.60)	320 (12.60)	65 (2.56)	162 (6.38)	24 kg / 52 lb

Unit: mm(in)

## PPC / PPM



● Pallet chuck

**Use:**  
Clamping for palletizing system

- Features:**
- Pole pitch 0.5+1.5 mm
  - Max magnetic clamping force up to 120 N/cm<sup>2</sup>
  - No residual magnetism
  - High precision and low flux depth 6 mm
  - Very light switching force
  - High accuracy guaranteed through entire service life

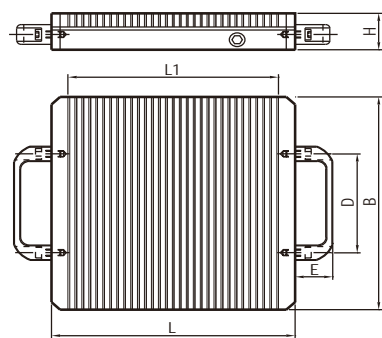

Model	Width	Length	Height	L1	D	E	Net Weight
PPC-2424/40	240 (9.45)	240 (9.45)	40 (1.57)	197 (7.76)	130 (5.12)	40 (1.57)	16 kg / 35 lb
PPC-2828/40	280 (11.02)	280 (11.02)	40 (1.57)	237 (9.33)	130 (5.12)	40 (1.57)	22 kg / 48 lb
PPC-3232/40	320 (12.60)	320 (12.60)	40 (1.57)	279 (10.98)	130 (5.12)	40 (1.57)	28 kg / 62 lb

Unit: mm(in)

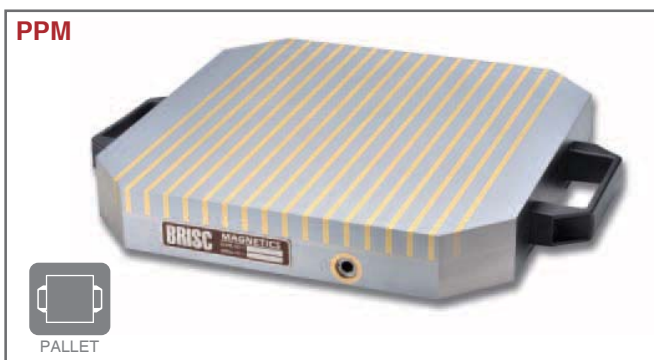

● Pallet chuck

**Use:**  
Clamping for palletizing system

- Features:**
- Pole pitch 4+11 mm
  - Max. Magnetic clamping force up to 180 N/cm<sup>2</sup>
  - No residual magnetism
  - Strong clamping force with low flux depth 12 mm
  - Easy to activate and de-activate
  - High accuracy guaranteed through entire service life

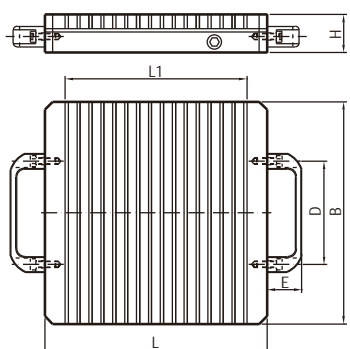

Model	Width	Length	Height	L1	D	E	Net Weight
PPM-2424-48	240 (9.45)	240 (9.45)	48 (1.89)	184 (7.24)	130 (5.12)	40 (1.57)	19 kg / 42 lb
PPM-2828-48	280 (11.02)	280 (11.02)	48 (1.89)	214 (8.43)	130 (5.12)	40 (1.57)	20 kg / 57 lb
PPM-3232-48	320 (12.60)	320 (12.60)	48 (1.89)	259 (10.20)	130 (5.12)	40 (1.57)	35 kg / 77 lb

Unit: mm(in)





## ● Square pole electro-permanent magnetic chuck with standard density

### Use:

Clamping for heavy machining for medium to large work pieces

### Features:

- Square pole size 50x50 mm
- Magnetic force higher than 350 kg per pole
- Electro-permanent technology with no deformation owing to the rise of temperature
- Distortion free clamping with auto-shim pole extensions
- No residual magnetism
- Controlled flux prevents magnetization of the tool
- Flux depth 12 mm
- Workpiece larger than the table size are machinable
- Multiple magnet combinations can provide clamping for any table size, large or small

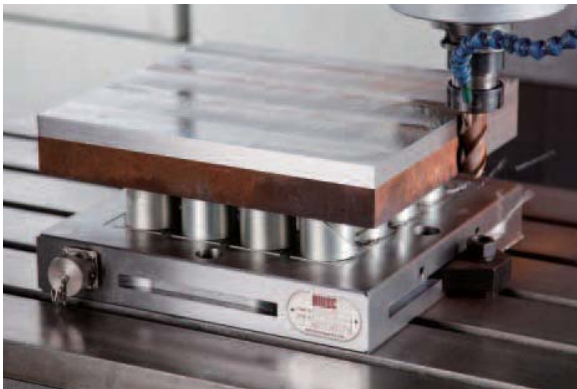

Model	Width	Length	Height	Pole No.	Net Weight	Controller (220V)	Controller (400/480V)
PSP-3634	360 (14.17)	340 (13.39)	59 (2.32)	20	56 kg / 123 lb	CUA	CUA
PSP-3649	360 (14.17)	490 (19.29)	59 (2.32)	30	82 kg / 180 lb	CUA	CUA
PSP-3664	360 (14.17)	640 (25.20)	59 (2.32)	40	107 kg / 235 lb	CUA	CUA
PSP-3679	360 (14.17)	790 (31.10)	59 (2.32)	50	133 kg / 293 lb	CUA	CUA
PSP-4264	420 (16.54)	640 (25.20)	59 (2.32)	48	126 kg / 277 lb	CUA	CUA
PSP-4279	420 (16.54)	790 (31.10)	59 (2.32)	60	156 kg / 343 lb	CUD	CUA
PSP-4294	420 (16.54)	940 (37.01)	59 (2.32)	72	186 kg / 410 lb	CUD	CUA
PSP-42109	420 (16.54)	1090 (42.91)	59 (2.32)	84	215 kg / 473 lb	CUD	CUA
PSP-4864	480 (18.90)	640 (25.20)	59 (2.32)	56	144 kg / 317 lb	CUA	CUA
PSP-4879	480 (18.90)	790 (31.10)	59 (2.32)	70	178 kg / 392 lb	CUD	CUA
PSP-4894	480 (18.90)	940 (37.01)	59 (2.32)	84	212 kg / 467 lb	CUD	CUA
PSP-48109	480 (18.90)	1090 (42.91)	59 (2.32)	98	246 kg / 542 lb	CUD	CUD
PSP-6064	600 (23.62)	640 (25.20)	59 (2.32)	72	180 kg / 396 lb	CUD	CUA
PSP-6079	600 (23.62)	790 (31.10)	59 (2.32)	90	223 kg / 491 lb	CUD	CUD
PSP-6094	600 (23.62)	940 (37.01)	59 (2.32)	108	265 kg / 584 lb	CUD	CUD
PSP-60109	600 (23.62)	1090 (42.91)	59 (2.32)	126	308 kg / 679 lb		CUD

Unit: mm(in)

## Pole Extension

### • Fix pole extensions

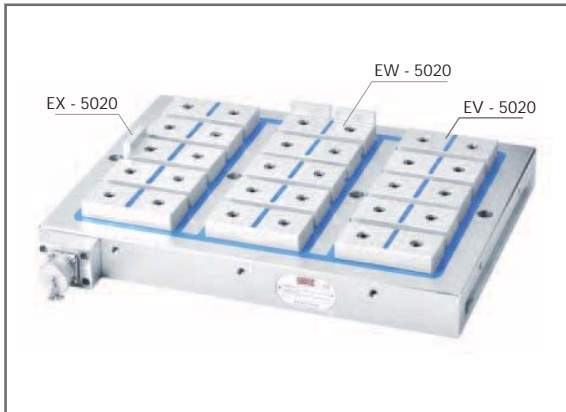

### • Auto-shim pole extensions



**EV-5020**  
50x50 mm fix pole extension with height 20 mm



**EW-5020**  
50x50 mm fix pole extension with height 20 mm and step



**EX-5020**  
50x50 mm fix pole extension with height 20 mm and step



**ES-5052**  
Diameter 50 mm auto-shim pole extension with height 52 mm



**ET-5052**  
Diameter 50 mm auto-shim pole extension with height 52 mm



**EE-5020**  
50x50 mm fix pole extension with height 20 mm and step



**EA-5020**  
50x50 mm fix pole extension with height 20 mm



**EA-5050**  
50x50 mm fix pole extension with height 50 mm



**EC-5050**  
50x50 mm auto-shim pole extension with height 50 mm



**ES-5052**

### Fix pole extensions

ES fixed and ET self shimming pole extensions using the built in threaded rod which does not require tools to install or remove.



**ET-5052**

### Mobile pole extensions

The new and improved ET pole extension has increased the performance of the original ET by 20%. Total adjustment is 6 mm.

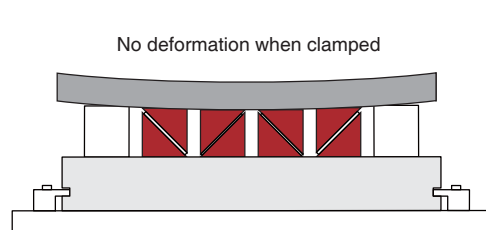
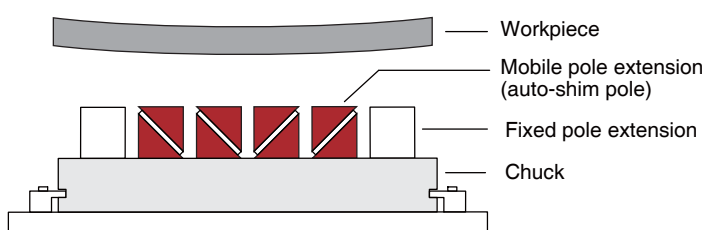



● Square pole electro-permanent magnetic chuck with standard density

**Use:**

Clamping for heavy machining for medium to large work pieces

**Features:**

- Square pole size 50x50 mm
- Magnetic force higher than 350 kg per pole
- Electro-permanent technology with no deformation owing to the rise of temperature
- Distortion free clamping with auto-shim pole extensions
- No residual magnetism
- Controlled flux prevents magnetization of the tool
- Flux depth 12 mm
- Workpiece larger than the table size are machinable

Milling

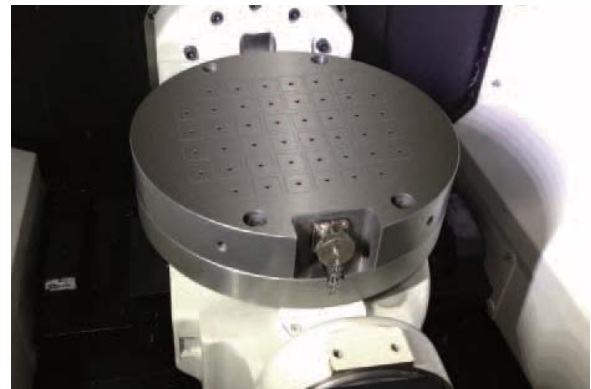

Model	Diameter	Height	Pole No.	Net Weight	Controller (220V)	Controller (400/480V)
PRP-400	400 (15.75)	45 (1.77)	21	42 kg / 92.6 lb	CUA	CUA
PRP-500	500 (19.69)	45 (1.77)	32	66 kg / 145.5 lb	CUA	CUA
PRP-600	600 (23.62)	45 (1.77)	52	95 kg / 209.4 lb	CUA	CUA
PRP-700	700 (27.56)	45 (1.77)	68	130 kg / 286.6 lb	CUD	CUA
PRP-800	800 (31.50)	45 (1.77)	96	170 kg / 374.8 lb	CUD	CUD
PRP-900	900 (35.43)	45 (1.77)	120	214 kg / 471.7 lb	CUF	CUD
PRP-1000	1000 (39.37)	45 (1.77)	156	265 kg / 584.2 lb	CUF	CUD

Unit: mm(in)

## PMM

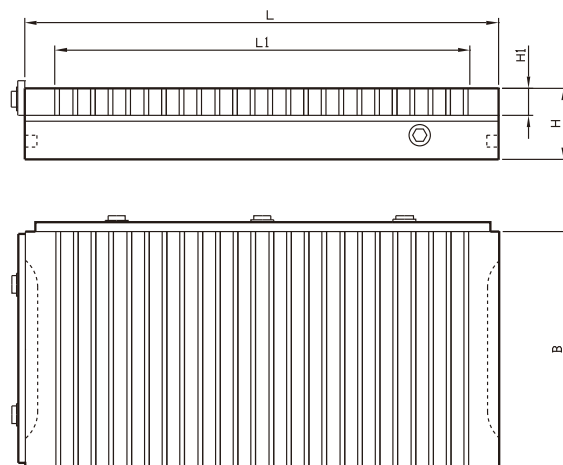

### • Permanent magnetic chuck for milling

#### Use:

Clamping for heavy machining operation

#### Features:

- Pole pitch 4+11 mm
- Max. magnetic clamping force up to 180 N/cm<sup>2</sup>
- Highly concentrated magnetic field with low flux depth 6 mm
- Low flux depth prevents magnetization of the tooling
- Coolant and water proof structure
- Easy to activate and de-activate
- High precision with no residual magnetism



Model	Width	Length	Effective Length	Height	H1	Net Weight
PMM-1525	150 (5.91)	250 (9.84)	199 (7.83)	60 (2.36)	23 (0.91)	17 kg / 37 lb
PMM-1530	150 (5.91)	300 (11.81)	259 (10.20)	60 (2.36)	23 (0.91)	20 kg / 44 lb
PMM-1535	150 (5.91)	350 (13.78)	304 (11.97)	60 (2.36)	23 (0.91)	24 kg / 53 lb
PMM-1545	150 (5.91)	450 (17.72)	409 (16.10)	60 (2.36)	23 (0.91)	31 kg / 68 lb
PMM-2030	200 (7.87)	300 (11.81)	259 (10.20)	60 (2.36)	23 (0.91)	29 kg / 64 lb
PMM-2040	200 (7.87)	400 (15.75)	349 (13.74)	60 (2.36)	23 (0.91)	37 kg / 81 lb
PMM-2045	200 (7.87)	450 (17.72)	409 (16.10)	60 (2.36)	23 (0.91)	41 kg / 90 lb
PMM-2050	200 (7.87)	500 (19.69)	454 (17.84)	60 (2.36)	23 (0.91)	46 kg / 101 lb
PMM-2060	200 (7.87)	600 (23.62)	559 (22.01)	60 (2.36)	23 (0.91)	55 kg / 121 lb
PMM-2530	250 (9.84)	300 (11.81)	259 (10.20)	60 (2.36)	23 (0.91)	35 kg / 77 lb
PMM-2535	250 (9.84)	350 (13.78)	304 (11.97)	60 (2.36)	23 (0.91)	41 kg / 90 lb
PMM-2540	250 (9.84)	400 (15.75)	349 (13.74)	60 (2.36)	23 (0.91)	47 kg / 103 lb
PMM-2545	250 (9.84)	450 (17.72)	409 (16.10)	60 (2.36)	23 (0.91)	52 kg / 342 lb
PMM-3030	300 (11.81)	300 (11.81)	259 (10.20)	60 (2.36)	23 (0.91)	39 kg / 86 lb
PMM-3040	300 (11.81)	400 (15.75)	349 (13.74)	60 (2.36)	23 (0.91)	52 kg / 114 lb
PMM-3050	300 (11.81)	500 (19.69)	459 (18.07)	60 (2.36)	23 (0.91)	65 kg / 143 lb
PMM-3060	300 (11.81)	600 (23.62)	559 (22.01)	60 (2.36)	23 (0.91)	80 kg / 176 lb
PMM-4040	400 (15.75)	400 (15.75)	349 (13.74)	60 (2.36)	23 (0.91)	71 kg / 156 lb

Unit: mm(in)

**• Electro-permanent magnetic module with double sided clamping surfaces**

**Use:**

Clamping for heavy machining for medium to large work pieces

**Features:**

- With double sided clamping surfaces
- Can be self-clamped on the machine table
- Top surface clamping and bottom surface clamping can be controlled by different channels
- Channel 1 for top surface clamping, Channel 2 for bottom surface clamping
- Square pole size 70x70 mm
- Magnetic force higher than 690 kg per pole
- With no deformation owing to the rise of the temperature
- No residual magnetism
- Workpiece larger than the table size are machinable
- Multiple magnet combinations can provide clamping for any table size

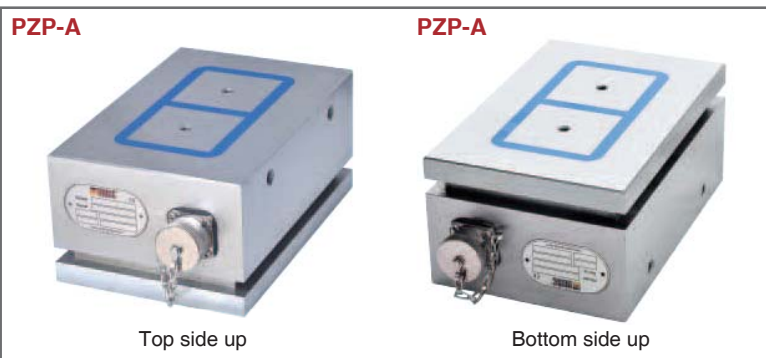
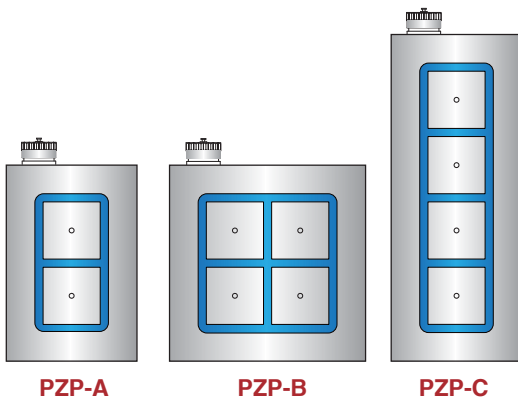

CUT-A with channel selection function  
Channel 1 for top, Channel 2 for bottom



**Application 1**

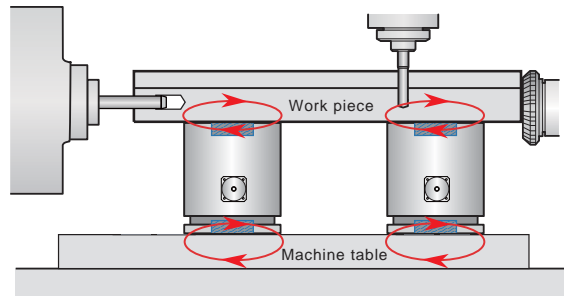

**Application 2**

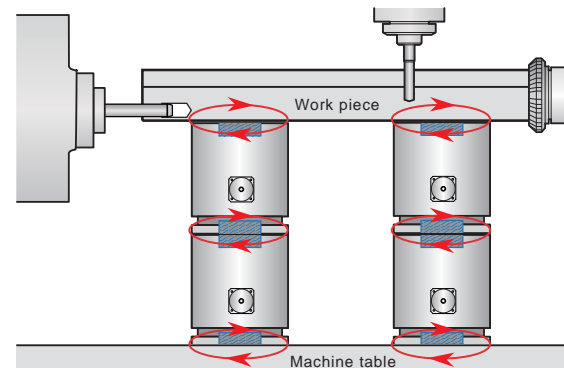

Model	Width	Length	Height	Pole No.	Net Weight	Control Unit (220 / 400V)	Clamping Force per side
PZP-A	160 (6.29)	240 (9.44)	110 (4.33)	2 x 2	33 kg / 62 lb	CUT-A	13.8 kN
PZP-B	240 (9.44)	240 (9.44)	110 (4.33)	4 x 2	49 kg / 62 lb	CUT-A	27.6 kN
PZP-C	160 (6.29)	400 (15.74)	110 (4.33)	4 x 2	59 kg / 62 lb	CUT-A	27.6 kN

Unit: mm(in)

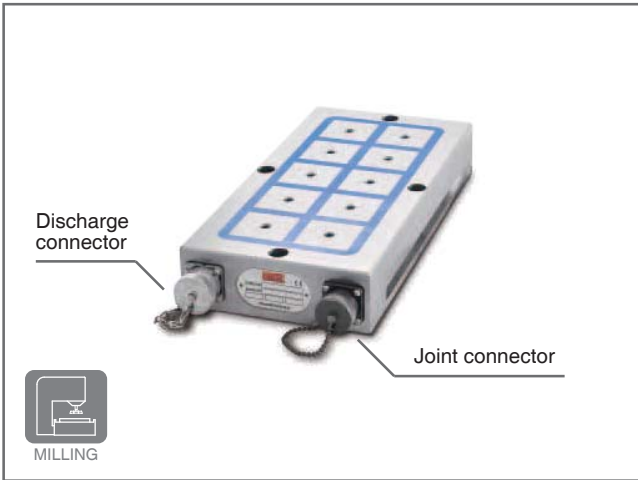

**• Electro-permanent magnetic chuck**

**Use:**  
Clamping for heavy machining for medium to large work pieces

- Features:**
- Square pole size 50x50 mm
  - Magnetic force higher than 350 kg per pole
  - Electro-permanent technology with no deformation owing to the rise of the temperature
  - Distortion free clamping with auto-shim pole extensions
  - No residual magnetism
  - Controlled flux prevents magnetization of the tool
  - Workpiece larger than the table size are machinable
  - Multiple magnet combinations can provide clamping for any table size, large or small
  - Length of connection cable can be made to order

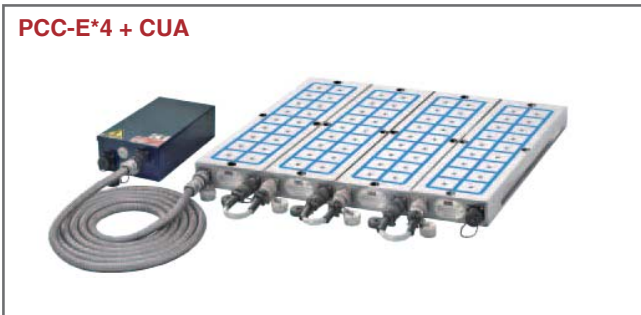
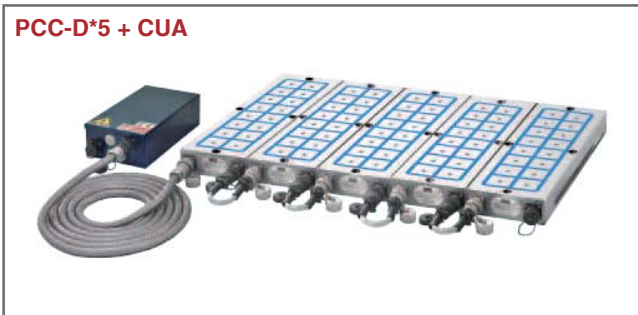
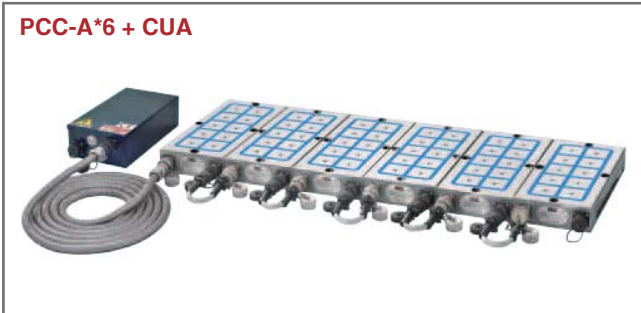
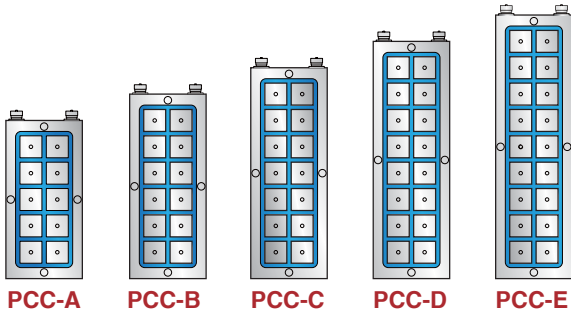

Model	Width	Length	Heigh	Pole No.	Max Plate No.	Net Weight	Control Unit	Clamping Force
PCC-A	174 (6.85)	360 (14.17)	59 (2.32)	10	6	24 kg / 53 lb	CUA	35 kN
PCC-B	174 (6.85)	420 (16.54)	59 (2.32)	12	6	33 kg / 73 lb	CUA	42 kN
PCC-C	174 (6.85)	480 (18.90)	59 (2.32)	14	5	38 kg / 84 lb	CUA	49 kN
PCC-D	174 (6.85)	540 (21.26)	59 (2.32)	16	5	43 kg / 95 lb	CUA	56 kN
PCC-E	174 (6.85)	600 (23.62)	59 (2.32)	18	4	48 kg / 106 lb	CUA	63 kN

Unit: mm(in)

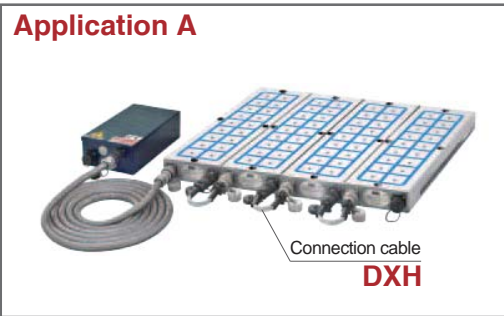

- Can be used next to each other

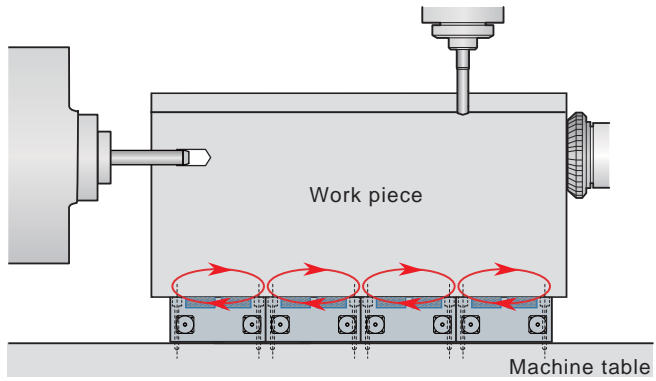

- Can be used with space in between

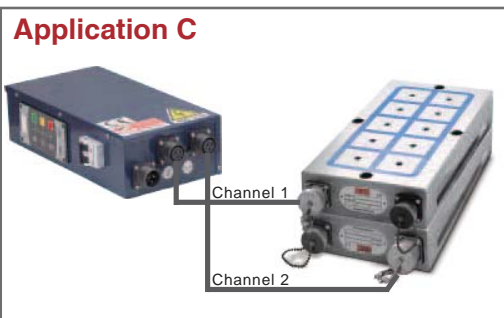
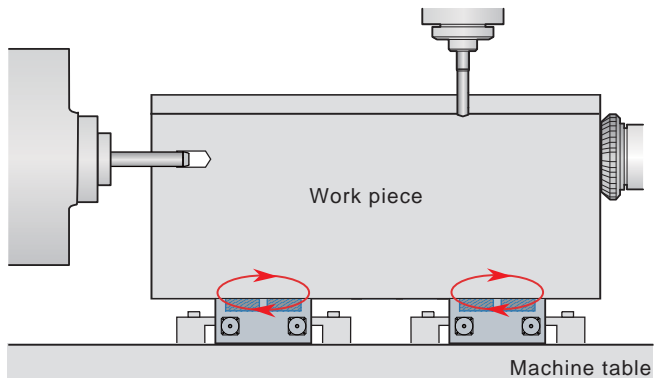

- Can bolt-together two PCC and make it two clamping surface separately

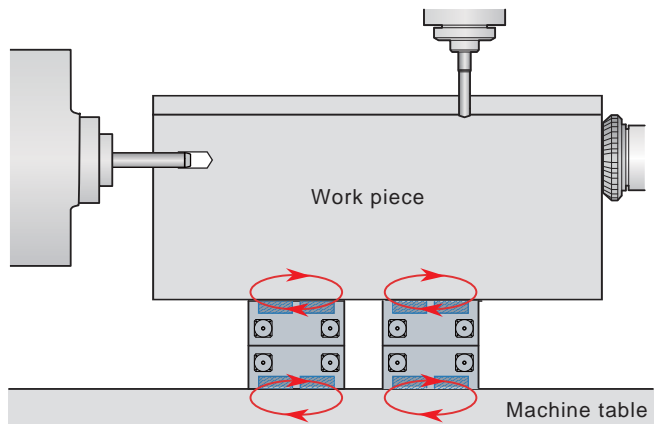

Model	Cable length	Space between chucks	Description
DXH-300	300 (11.8)	0 - 50 (0 - 1.96)	connection cable

Unit: mm(in)

Model	Cable length	Description
DXF-1000	1000 (39.4)	extension cable

Unit: mm(in)

Different length cable is available upon request.

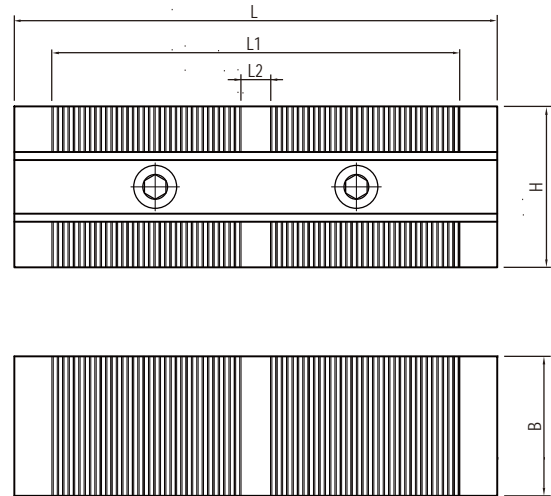

• Permanent magnetic chuck

**Use:**

Clamping device for holding workpieces securely on spark erosion machines (EDM) or other machining applications, or as part of a fixture.

**Features:**

- Two clamping surfaces on opposite and individually switchable
- PFD with pole pitch 0.5+1.5 mm
- Max. magnetic uniform clamping force up to 120 N/cm<sup>2</sup>
- Easy to activate and de-activate
- Coolant and water proof structure
- High precision and no residual magnetism
- Can be supplied in pairs

Model	Width(B)	Length(L)	Height(H)	L1	L2	P	Net Weight
PFD-0513	52 (2.05)	125 (4.92)	60 (2.36)	99 (3.90)	-	1.5+0.5	3.0 kg / 6.6 lb
PFD-0518	52 (2.05)	180 (7.09)	60 (2.36)	152.5 (6.00)	11 (0.43)	1.5+0.5	4.2 kg / 9.3 lb
PFD-0525	52 (2.05)	250 (9.84)	60 (2.36)	224.5 (8.84)	11 (0.43)	1.5+0.5	5.8 kg / 12.8 lb

Unit: mm(in)

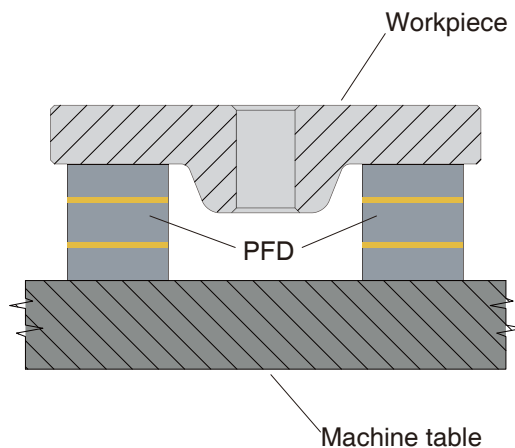



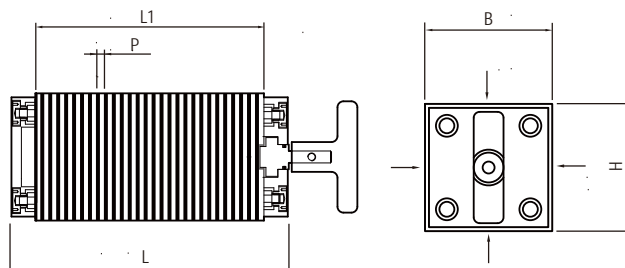

EDM

**• Permanent magnetic chuck**

**Use:**  
Angular and parallel EDM of small and medium-sized workpieces

- Features:**
- Robust construction with good holding force
  - Pole pitch 2 mm bass / 2 mm steel
  - Nominal holding force standard: 50 N/cm<sup>2</sup>
  - Nominal holding force stainless 30 N/cm<sup>2</sup>
  - Magnetic field height : 2 mm
  - Polar plate re-grind of 4 mm
  - Stainless, chrome steel polar plates available for use in wire EDM



Model	Width(B)	Length(L)	Height(H)	L1	P	Net Weight
MBF-140	64 (2.52)	140 (5.51)	64 (2.52)	115 (4.53)	2+2	3.0 kg / 6.6 lb
MBF-160	64 (2.52)	160 (6.30)	64 (2.52)	135 (5.31)	2+2	4.0 kg / 8.8 lb

Unit: mm(in)



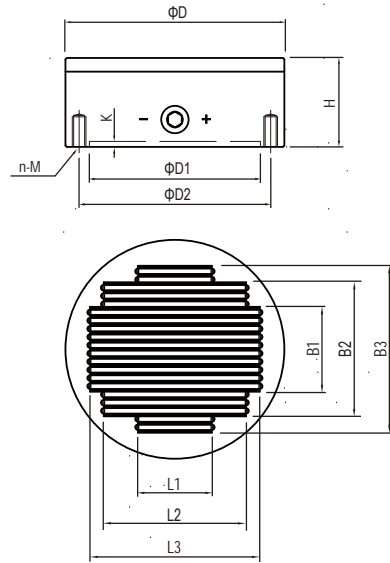

### • Permanent magnetic chuck

#### Use:

For hard to hold parts requiring exceptionally high power, such as high alloyed tool steels and materials containing cobalt.

#### Features:

- Aluminium housing, pole plate made from tool steel. Extremely high clamping force through neodymium-iron-boron magnets
- Available with flange on request
- NF with pole pitch 2 + 4 mm
- Max. uniform magnetic clamping force up to 180N/cm<sup>2</sup>
- Best for small and thin workpiece
- Magnetic field height : 4 mm
- Polar plate re-grind of 3mm
- High precision with no residual magnetism

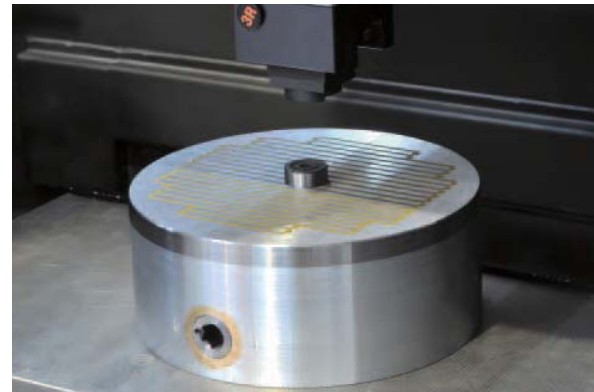

Model	Dia(D1)	Height(H)	L1	L2	L3	B1	B2	D2	D4	n	M	K	Net Weight
NF-100	100(3.94)	65(2.56)	48(1.89)	-	-	74(2.91)	-	70(2.76)	90(3.54)	4	6	4	2.2kg/4.8 lb
NF-125	125(4.92)	65(2.56)	54(2.13)	88(3.46)	-	67(2.64)	98(3.86)	95(3.74)	110(4.33)	5	8	4	3.4kg/7.5lb
NF-160	160(6.30)	65(2.56)	54(2.13)	104(4.09)	124(4.88)	62(2.44)	98(3.86)	125(4.92)	140(5.51)	6	10	4	5.6kg/12.3 lb
NF-180	180(7.09)	65(2.56)	64(2.59)	104(4.09)	124(4.88)	62(2.44)	98(3.86)	125(4.92)	160(6.30)	7	10	4	7.1kg/15.6lb
NF-200	200(7.87)	65(2.56)	74(2.91)	104(4.09)	134(5.28)	73(2.87)	110(4.33)	125(4.92)	180(5.51)	8	10	4	8.7kg/19.2 lb

Unit: mm(in)

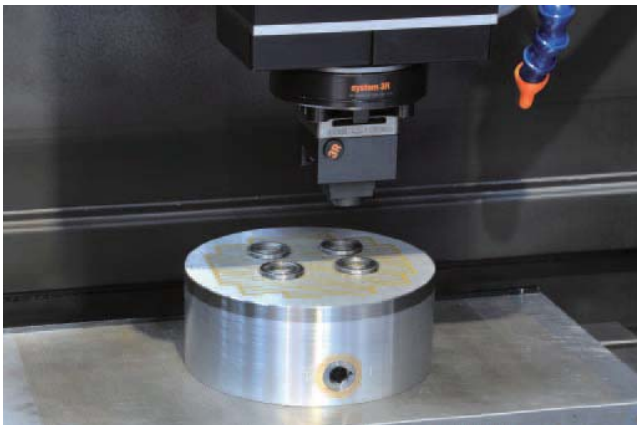

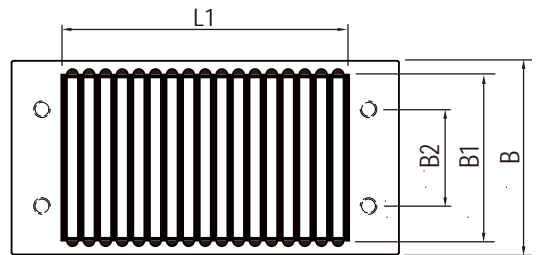
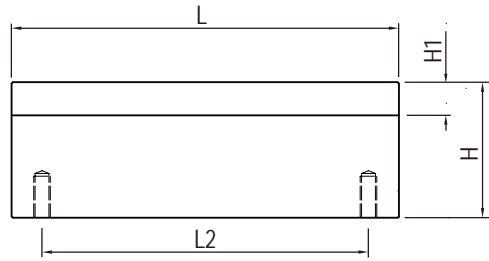

## • Permanent magnetic chuck

### Use:

For complex, small, hard to hold parts requiring extra accuracy and power

### Features:

- PMB with pole pitch 2 + 4 mm
- High polar plate stability of  $\pm 0.002$  mm
- Bigger sizes available on request
- Highest uniform clamping force up to 180 N/cm<sup>2</sup>
- Magnetic field height : 10 mm
- Polar plate re-grind of 3 mm
- Clamping of more than one workpiece is possible

Model	Width(B)	Length(L)	L1	L2	Height(H)	H1	B1	B2	Net Weight
PMB-714	70 (2.76)	140 (5.51)	118 (4.65)	100 (3.94)	49 (1.93)	12 (0.47)	60 (2.36)	35 (1.38)	3.5 kg / 7.7lb
PMB-720	70 (2.76)	200 (7.87)	170 (7.00)	150 (5.91)	49 (1.93)	12 (0.47)	60 (2.36)	35 (1.38)	5 kg / 11lb

Unit: mm(in)

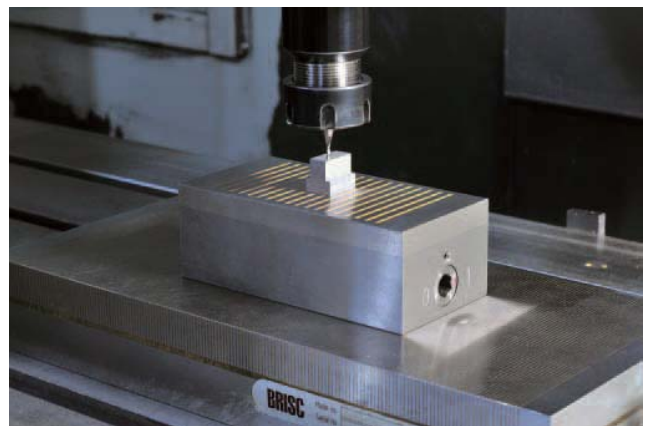

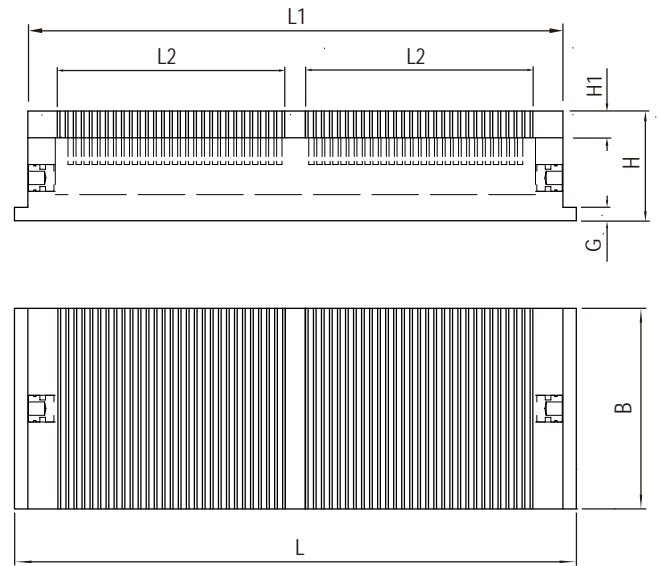

• Permanent magnetic chuck

**Use:**

For hard to clamp parts requiring exceptionally high power, such as high alloyed tool steels and materials containing cobalt

**Features:**

- Extremely high clamping force due to a specially developed construction, stable all-steel body
- ON-OFF control on both ends
- Larger models with power-operated switching mechanism available on request
- Pole pitch 4 mm ST and 2 mm with extra NdFeB between the poles
- Max. uniform magnetic clamping force up to 180 N/cm<sup>2</sup>
- Magnetic field height : 10 mm
- Polar plate re-grind of 3 mm

Model	Width(B)	Length(L)	Height(H)	L1	L2	H1	G	Net Weight
PMG-1540	150 (5.91)	420 (16.54)	82 (3.23)	400 (15.75)	170 (6.69)	20 (0.79)	10 (0.39)	33 kg / 73 lb

Unit: mm(in)

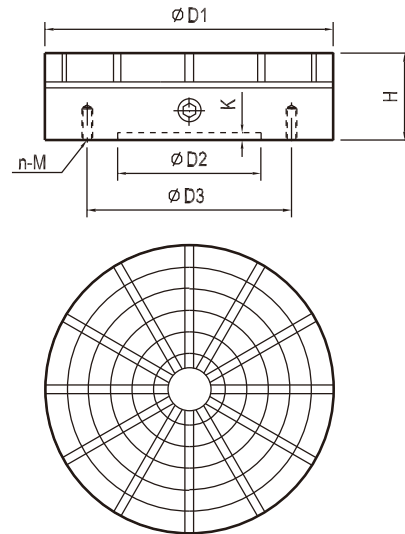

Turning

**• Circular permanent magnetic chuck with radial poles**

**Use:**  
Clamping for grinding and turning of ring-shaped workpieces

- Features:**
- Max. magnetic clamping force up to 180 N/cm<sup>2</sup>
  - Concentric grooves simplify the centring of workpiece
  - Balanced for high RPM
  - Centre through hole is available on request for workpiece
  - T-slots available on request for pole extensions allowing 3 sided access in single set-up



Model	Diameter(D)	Height	D2	D3	n	M	K	Net Weight
NR-100	100 (3.94)	60 (2.36)	60 (2.36)	85 (3.35)	4	6	4 (0.16)	3.3 kg / 7.26 lb
NR-130	130 (5.12)	60 (2.36)	50 (1.97)	100 (3.94)	4	6	4 (0.16)	6 kg / 13 lb
NR-150	150 (5.91)	60 (2.36)	90 (3.54)	115 (4.53)	4	8	4 (0.16)	8 kg / 18 lb
NR-160	160 (6.30)	60 (2.36)	120 (4.72)	140 (5.51)	4	8	4 (0.16)	10 kg / 22 lb
NR-200	200 (7.87)	60 (2.36)	160 (6.30)	180 (7.09)	4	8	4 (0.16)	14 kg / 31 lb
NR-250	250 (9.84)	60 (2.36)	200 (7.87)	230 (9.06)	4	10	4 (0.16)	23 kg / 51 lb
NR-300	300 (11.81)	80 (3.15)	250 (9.84)	270 (10.63)	7	12	4 (0.16)	43 kg / 95 lb
NR-320	320 (12.60)	80 (3.15)	250 (9.84)	270 (10.63)	6	12	4 (0.16)	50 kg / 110 lb
NR-350	350 (13.78)	80 (3.15)	250 (9.84)	280 (11.02)	6	12	4 (0.16)	59 kg / 130 lb
NR-400	400 (15.75)	80 (3.15)	200 (7.87)	260 (10.24) / 340 (13.39)	12	10	6 (1.81)	78 kg / 172 lb
NR-500	500 (19.69)	95 (3.74)	200 (7.87)	300 (11.81) / 400 (15.75)	12	10	8 (0.31)	146 kg / 321 lb
NR-600	600 (23.62)	95 (3.74)	250 (9.84)	350 (13.78) / 450 (17.72)	12	10	8 (0.31)	210 kg / 462 lb

Unit: mm(in)

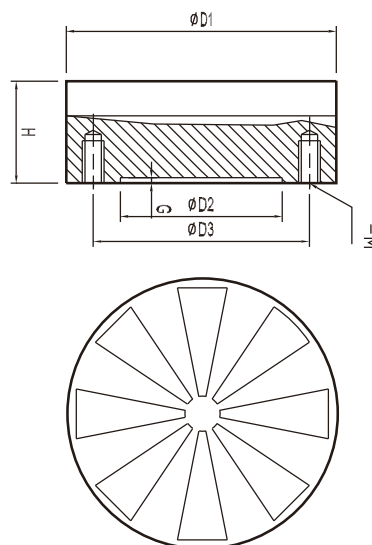

### • Circular electro-permanent magnetic chuck with radial poles

#### Use:

Clamping for turning or grinding of ring shaped workpieces

#### Features:

- Max. magnetic clamping force up to 160 N/cm<sup>2</sup>
- Electro-permanent technology with no deformation owing to the rise of temperature
- Can eliminate the residual magnetism from the workpiece
- T-slot available on request for pole extensions allowing 3 sided access in single set-up
- Mono-block housing for maximum stability

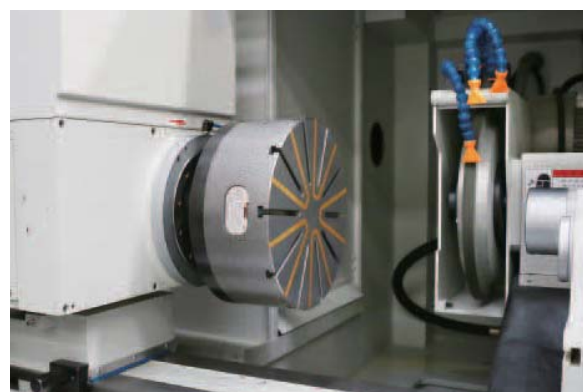

Model	Size (D1)	Height (H)	D2	D3	n	M	G	Pole No.	Net weight	Controller (400V)
EPW-G/S	300 (11.81)	105 (4.13)	160 (6.30)	190 (7.48)	5	12	4 (0.16)	10	55 kg / 121 lb	CGA
EPW-G/S	400 (11.75)	115 (4.53)	200 (7.87)	280 (11.02)	6	12	4 (0.16)	12	107 kg / 236 lb	CGA
EPW-G/S	500 (19.68)	120 (4.72)	280 (11.02)	320 (12.6)	7	12	4 (0.16)	14	158 kg / 348 lb	CGA
EPW-G/S	600 (23.62)	120 (4.72)	350 (13.78)	390 (15.35)	8	12	4 (0.16)	16	227 kg / 499 lb	CGA
EPW-G/S	700 (27.56)	120 (4.72)	400 (15.75)	450 (17.72)	8	16	4 (0.16)	16	310 kg / 682 lb	CGD
EPW-G/S	800 (31.50)	120 (4.72)	450 (17.72)	500 (19.69)	8	16	4 (0.16)	16	404 kg / 889 lb	CGD
EPW-G/S	1000 (39.37)	120 (4.72)	550 (21.65)	620 (24.41)	8	16	4 (0.16)	24	632 kg / 1391 lb	CGD
EPW-G/S	1250 (49.21)	125 (4.92)							1076 kg / 2367 lb	
EPW-G/S	1600 (62.99)	125 (4.92)							1763 kg / 3879 lb	Upon request
EPW-G/S	1800 (70.87)	125 (4.92)							2232 kg / 4910 lb	request
EPW-G/S	2000 (78.74)	125 (4.92)							2755 kg / 6061 lb	

Unit: mm(in)



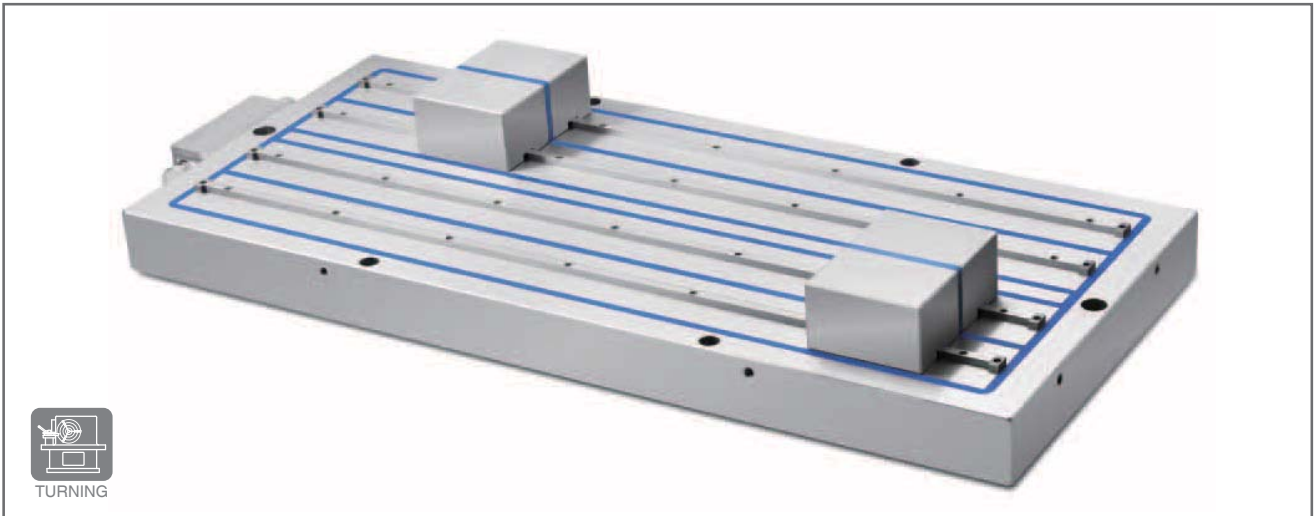

● **Electro-permanent magnetic chuck for heavy turning**

**Use:**  
Universal clamping for heavy turning

- Features:**
- Sliding pole extension
  - Max. magnetic clamping force up to 180 N/cm<sup>2</sup>
  - Highly concentrated magnetic field with low flux depth
  - Prevents magnetization of tooling
  - Coolant proof structure
  - Easy to deploy
  - High precision with no residual magnetism
  - Easy and economic to use with different modules combination

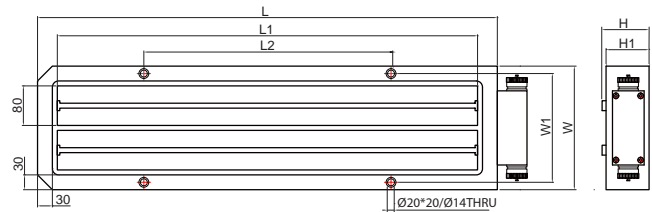

■ Sliding pole extensions

Model	Width(W)	Length(L)	L1	L2	W1	Height(H)	H	Net weight
PR80-2545	250 (9.8)	450 (17.7)	370 (14.6)	350 (13.8)	220 (8.7)	80 (3.1)	87 (3.4)	73 kg / 160 lb
PR80-25100	250 (9.8)	930 (36.6)	850 (33.5)	500 (19.7)	220 (8.7)	80 (3.1)	87 (3.4)	160 kg / 352 lb
PR80-46100	460 (18.1)	1040 (40.9)	950 (37.4)	500 (19.7)	430(16.9)	80 (3.1)	87 (3.4)	228 kg / 502 lb

Unit: mm(in)

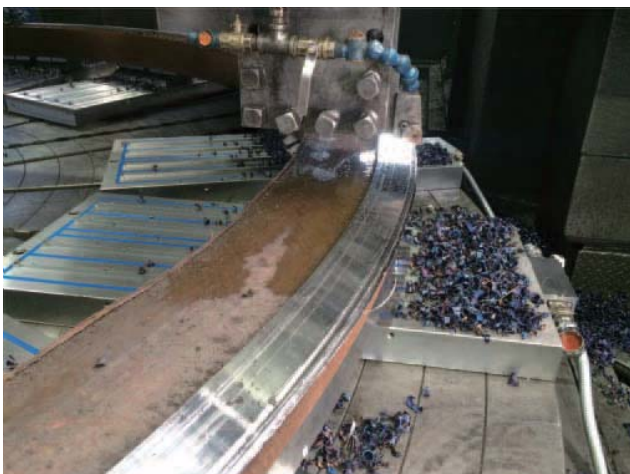

## PLM

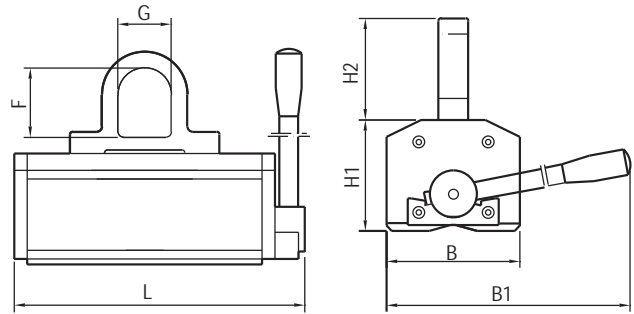

### • Permanent lifting magnet

#### Use:

For lifting ferromagnetic material, bar stock, cold rolled

#### Features:

- High power to weight ratio
- Compact and light
- Minimum of 3X safety factor
- Suitable for flat and round material
- Maintenance free design
- Safety device prevent accidental deactivation
- Can be switched off by one hand only



Model	Safe Working Load	Width	Length	H1	H2	B1	F	G	Net Weight
PLM-100	100 kg / 220 lb	70 (2.76)	130 (5.12)	60 (2.36)	53 (2.09)	176 (6.93)	35 (1.38)	28 (1.10)	3.5 kg / 8 lb
PLM-300	300 kg / 660 lb	95 (3.74)	205 (8.07)	83 (3.27)	70 (2.76)	220 (8.66)	47 (1.85)	40 (1.57)	10 kg / 22 lb
PLM-600	600 kg / 1320 lb	125 (4.92)	272 (10.71)	104 (4.09)	95 (3.74)	296 (11.65)	64 (2.52)	50 (1.97)	23 kg / 51 lb
PLM-1000	1000 kg / 2200 lb	160 (6.30)	318 (12.52)	140 (5.51)	95 (3.74)	410 (16.14)	64 (2.52)	50 (1.97)	44 kg / 97 lb
PLM-2000	2000 kg / 4400 lb	160 (6.30)	496 (19.53)	140 (5.51)	120 (4.72)	508 (20.00)	80 (3.15)	60 (2.36)	72 kg / 158 lb
PLM-3000	3000 kg / 6600 lb	230 (9.06)	510 (20.08)	212 (8.35)	155 (6.10)	600 (23.62)	100 (3.94)	70 (2.76)	160 kg / 352 lb
PLM-5000	5000 kg / 11000 lb	360 (14.17)	725 (28.54)	261 (10.28)	180 (7.09)	980 (38.58)	100 (3.94)	70 (2.76)	450 kg / 990 lb

Model	Load Plate Max	Plate Min Thickness	Plate Max Length	Load Round Max Round	Min Thickness	Round Max Diameter
PLM-100	100 kg / 220 lb	15 (0.59)	1000 (39.37)	40 kg / 88 lb	8 (0.31)	150 (5.9)
PLM-300	300 kg / 660 lb	20 (0.79)	1500 (59.06)	120 kg / 264 lb	12 (0.47)	180 (7.09)
PLM-600	600 kg / 1320 lb	25 (0.98)	2000 (78.74)	240 kg / 528 lb	20 (0.79)	250 (9.84)
PLM-1000	1000 kg / 2200 lb	40 (1.57)	3000 (118.11)	400 kg / 880 lb	25 (0.98)	280 (11.02)
PLM-2000	2000 kg / 4400 lb	55 (2.17)	3000 (118.11)	800 kg / 1760 lb	35 (1.38)	350 (13.78)
PLM-3000	3000 kg / 6600 lb	70 (2.76)	3500 (137.8)	1200 kg / 2640 lb	45 (1.77)	400 (15.75)
PLM-5000	5000 kg / 11000 lb	85 (3.35)	4000 (157.48)	2000 kg / 4400 lb	55 (2.17)	450 (17.7)

Unit: mm(in)



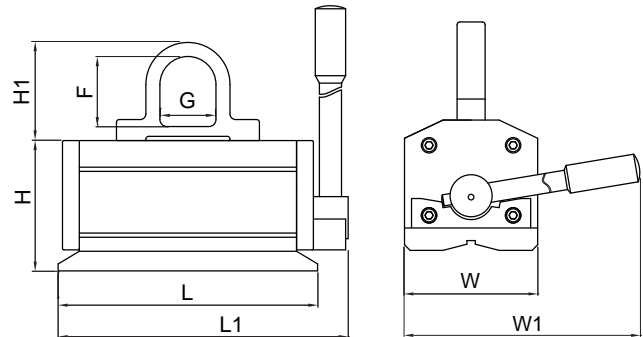

Lifting

**• Permanent lifting magnet for safe handling of thin plates**

**Use:**

Plate handling for thin plates  
De-stack down to 10 mm plates

**Features:**

- Special design allows controlled depth of flux
- High power with shallow flux depth, Specifically designed for de-stacking thin plates
- High capacity with low flux depth



Model	Width(W)	Length(L)	Height(H)	H1	W1	L1	G	F	Net Weight
PLM-T-150	95 (3.74)	185 (7.28)	93 (3.66)	70 (2.76)	160 (6.30)	208 (8.19)	40 (1.57)	50 (1.97)	10 kg / 22 lb
PLM-T-300	125 (4.92)	250 (9.84)	114 (4.49)	95 (3.74)	296 (11.65)	275 (10.83)	50 (1.97)	65 (2.56)	19 kg / 42 lb

Model	Flat load Max	Min Thickness	Max Length	Load Round Max	Round Min Diameter	Round Max Diameter
PLM-T-150	150 kg / 330 lb	10 (0.39)	1200 (47.24)	60 kg / 132 lb	60 (2.36)	180 (7.09)
PLM-T-300	300 kg / 660 lb	12 (0.47)	1500 (59.06)	120 kg / 264 lb	60 (2.36)	180 (7.09)

Unit: mm(in)

## PLM-R

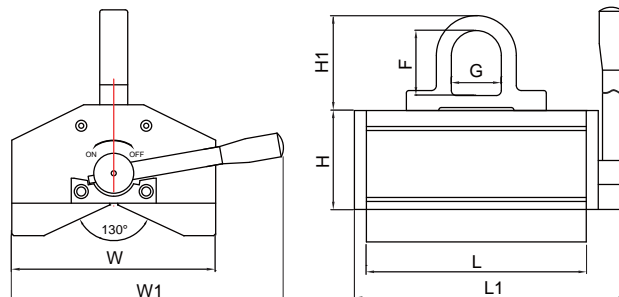

- Permanent lifting magnet for safe handling of round work piece

### Use:

Round or flat, the "safest" way to handle a load.

### Features:

- Larger V shape pole shoes than standard PLM to ensure safer conditions
- Higher performance on rounds than standard PLM
- Larger V for higher stability on round stock
- Low flux depth allowing de-stacking of thin loads



Model	Width(W)	Length(L)	Height(H)	H1	W1	L1	G	F	Net Weight
PLM-R-300	123 (4.84)	155 (6.10)	94 (3.70)	70 (2.76)	220 (8.66)	215 (8.46)	40 (1.57)	50 (1.97)	15 kg / 33 lb
PLM-R-600	204 (8.03)	220 (8.66)	131 (5.16)	95 (3.74)	296 (11.65)	272 (10.71)	50 (1.97)	65 (2.56)	38 kg / 84 lb
PLM-R-1000	280 (11.02)	252 (9.92)	178 (7.01)	95 (3.74)	410 (16.14)	252 (9.92)	50 (1.97)	65 (2.56)	85 kg / 187 lb
PLM-R-2000	280 (11.02)	252 (9.92)	178 (7.01)	95 (3.74)	508 (20.00)	496 (19.53)	60 (2.36)	80 (3.15)	150 kg / 330 lb
PLM-R-3000	444 (17.48)	429 (16.89)	293 (11.54)	155 (6.10)	600 (23.62)	509 (20.04)	70 (2.76)	100 (3.94)	340 kg / 748 lb

Model	Flat load Max	Min Thickness	Max Length	Load Round Max	Round Min Diameter	Round Max Diameter
PLM-R-300	300 kg/660 lb	20 (0.79)	1500 (59.06)	150 kg/330 lb	60 (2.36)	200 (7.87)
PLM-R-600	600 kg/1320 lb	25 (0.98)	2000 (78.74)	300 kg/660 lb	60 (2.36)	300 (11.81)
PLM-R-1000	1000 kg/2200 lb	40 (1.57)	3000 (118.11)	500 kg/1100 lb	80 (3.15)	360 (14.17)
PLM-R-2000	2000 kg/4400 lb	55 (2.17)	3000 (118.11)	1000 kg/2200 lb	80 (3.15)	460 (18.11)
PLM-R-3000	3000 kg/6600 lb	70 (2.76)	3500 (137.8)	1500 kg/3300 lb	100 (3.94)	560 (22.05)

Unit: mm(in)

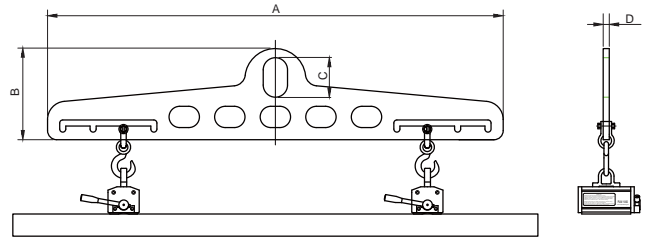
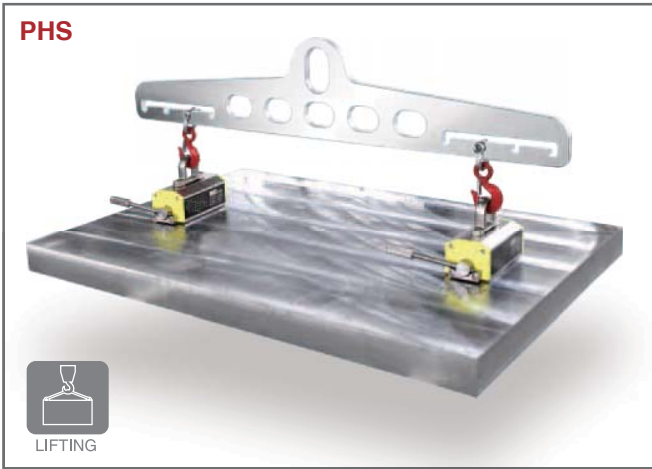

### ● PHS - PLM Fixed Beam

#### Features:

- The PHS spreader beam allows for the mounting of 2 PLM lifters increasing the load handling characteristics without complicating the overall simplicity of the process.
- PHS 500 handles loads up to 500 kgs and 3000mm while PHS 2000 handles loads up to 2000kg and 5000mm in length.



	PHS 500	PHS 2000
A (mm)	1500	1900
B (mm)	300	415
C (mm)	130	160
D (mm)	15	20
Weight (kg)	34	75

	PHS 500	PHS 500	PHS 2000	PHS 2000
In Combination with:	2 x PLM-300	2 x PLM-600	2 x PLM-600	2 x PLM-1000
Load (kg)	480	960	960	1600
Max Length (mm)	3000	3000	3000	3000
Max Width (mm)	1500	1500	1500	1500
Load (kg)	240	480	480	750
Max Length (mm)	3000	3000	3000	3000

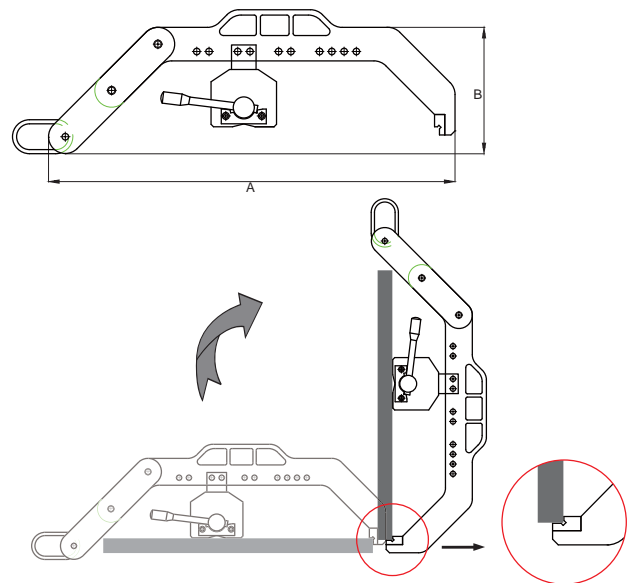

### ● PVS - PLM Vertical System

#### Features:

- PVS system is designed to rotate flat plates from horizontal to vertical and back.
- Can be used to flip parts over in a safe manner using simple stalls
- PVS is adaptable to workpieces of different sizes, changing the position of locking pins.
- PVS is available for PLM 300/600/1000.

#### Technical characteristics

Model	PVS 300	PVS 600	PVS 1000
A (mm)	695	892	995
B (mm)	250	320	352
C (mm)	110	140	140
D (mm)	100	160	252
Weight (kg)	20	41	63
Load Max (kg)	210	420	700
Max length plate (mm)	800	1000	1000
Max height plate (mm)	550	700	800



## CUA / CUD / CUT



● **One channel control unit**

**Use:**  
Electro-permanent magnetics modules for milling

- Features:**
- Multiple input voltage choices
  - Micro computer controls self testing and magnetizing detection
  - Good for both 50 Hz and 60 Hz
  - PLC connection built in
  - Safe and reliable
  - Including 5 meters power cable and 5 meters discharge cable



Model	Length	Width	Height	Net weight	Box
CUA-A	325 (12.80)	170 (6.69)	90 (3.54)	3.4 kg / 7.5 lb	Metal
CUA-H	250 (9.84)	150 (5.91)	100 (3.94)	1.6 kg / 3.5 lb	Plastic

Voltage	Max. Pole No. / channel	Pole size
220 V	56	50 x 50 mm
400 / 480 V	84	50 x 50 mm



● **Two channels control unit**

**Use:**  
Electro-permanent magnetics modules for milling

- Features:**
- Multiple input voltage choices
  - Micro computer controls self testing and magnetizing detection
  - Good for both 50 Hz and 60 Hz
  - PLC connection built in
  - Safe and reliable
  - Including 5 meters power cable and 5 meters discharge cable



Model	Length	Width	Height	Net weight	Box
CUD-A	325 (12.80)	170 (6.69)	90 (3.54)	3.4 kg / 7.5 lb	Metal
CUD-H	300 (11.81)	200 (7.87)	105 (4.13)	2.0 kg / 4.4 lb	Plastic

Voltage	Max. Pole No. / channel	Pole size
220 V	56	50 x 50 mm
400 / 480 V	84	50 x 50 mm



Model	Length	Width	Height	Net weight	Box
CUT-A	325 (12.80)	170 (6.69)	90 (3.54)	3.4 kg / 7.5 lb	Metal

● **Two channels control unit**

**Use:**  
Electro-permanent magnetics modules for milling

- Features:**
- Multiple input voltage choices
  - Micro computer controls self testing and magnetizing detection
  - Good for both 50 Hz and 60 Hz
  - PLC connection built in
  - Safe and reliable
  - Including 5 meters power cable and 5 meters discharge cable
  - With channel selection function

Voltage	Max. Pole No. / channel	Pole size
220 V	56	50 x 50 mm
400 / 480 V	84	50 x 50 mm



• One channel control unit

**Use:**  
Electro-permanent magnetics modules for grinding

- Features:**
- Multiple input voltage choices
  - Micro computer controls self testing and magnetizing detection
  - Good for both 50 Hz and 60 Hz
  - PLC connection built in
  - Safe and reliable
  - Strength adjustable

Model	Length	Width	Height	Net weight	Appilcatin
CGA-DT	250 (9.84)	150 (5.91)	100 (3.94)	1.6 kg / 3.5 lb	external
CGA-M	210 (8.27)	110 (4.33)	100 (3.94)	1 kg / 2.2 lb	internal

Voltage	Max. current per channel	Max. Pole No. per channel	Pole size
220 V	50 A	56	50 x 50 mm
400 / 480 V	50 A	84	50 x 50 mm



• Two channels control unit

**Use:**  
Electro-permanent magnetics modules for grinding

- Features:**
- Multiple input voltage choices
  - Micro computer controls self testing and magnetizing detection
  - Good for both 50 Hz and 60 Hz
  - PLC connection built in
  - Safe and reliable
  - Strength adjustable

Model	Length	Width	Height	Net weight	Appilcatin
CGD-DT	300 (11.81)	200 (7.87)	105 (4.13)	2.0 kg / 4.4 lb	external
CGD-M	260 (8.27)	110 (4.33)	100 (3.94)	1 kg / 2.2 lb	internal

Voltage	Max. current per channel	Max. Pole No. per channel	Pole size
220 V	50 A	56	50 x 50 mm
400 / 480 V	50 A	84	50 x 50 mm

**CUF / CUS / CUE**



**CGF / CGS / CGE**



**• Multi-channels control unit**

**Use:**  
Selectable channel multi-channel controller for electro-permanent magnets

- Features:**
- Multiple input voltage choices
  - Micro computer controls self testing and magnetizing detection
  - Good for both 50 Hz and 60 Hz
  - PLC connection built in
  - Safe and reliable
  - With channel selection function
  - Can be used jointly

Model	Length	Width	Height	Net weight	Channels
CUF	383 (15.08)	289 (11.38)	129 (5.08)	8 kg / 17.6 lb	4
CUS	383 (15.08)	289 (11.38)	129 (5.08)	8 kg / 17.6 lb	6
CUE	383 (15.08)	289 (11.38)	129 (5.08)	8 kg / 17.6 lb	8
CGF	383 (15.08)	289 (11.38)	129 (5.08)	8 kg / 17.6 lb	4
CGS	383 (15.08)	289 (11.38)	129 (5.08)	8 kg / 17.6 lb	6
CGE	383 (15.08)	289 (11.38)	129 (5.08)	8 kg / 17.6 lb	8

Voltage	Max. Pole No. / channel	Pole size
220 V	56	50 x 50 mm
400 / 480 V	84	50 x 50 mm

**RMC-1**



**RMC-2**



**RMC-3**



**RMC-9**



**• Remote control**

**Use:**  
For wire remote control

- Features:**
- Small and compact
  - With magnetic plate on the rear for ease of attachment

Model	Length	Width	Height	Strength adjustable	Channel Selection
RMC-1	136 (5.35)	66 (2.60)	41 (1.61)	Yes	No
RMC-2	136 (5.35)	66 (2.68)	55 (2.17)	Yes	No
RMC-3	136 (5.35)	66 (2.60)	41 (1.61)	No	No
RMC-9	136 (5.35)	66 (2.60)	41 (1.61)	Yes	Yes
RMC-10	136 (5.35)	66 (2.60)	41 (1.61)	No	Yes

**RMC-10**





● **Control unit for electromagnetic chucks**

Model	Length	Width	Height	Strength adjustable
CEB	260 (10.2)	160 (6.3)	90 (3.5)	Yes

**Use:**

Use with any electromagnetic chucks with input of 130 VAC and output 115 VDC and capacity of up to 500 watts

**Features:**

- External use design
- Push button control allows easy selection of full, residual, variable, and release positions
- Automatic release cycle assures workpiece release, while freeing machine operators from manual demagnetizing operations
- Current sense and E-stop interlock with machine
- Up to 16 pole reversal programs



● **Control unit for electromagnetic chucks**

Model	Length	Width	Height	Strength adjustable
CED	172 (6.8)	55 (2.2)	120 (4.7)	Yes

**Use:**

Use with any electromagnetic chucks with input of 130 VAC and output 115 VDC and capacity of up to 500 watts

**Features:**

- Internal use design
- Touchpad control allows easy selection of full, residual, variable, and release positions
- Automatic release cycle assures workpiece release, while freeing machine operators from manual demagnetizing operations
- Current sense and E-stop interlock with machine
- Up to 3 pole reversal programs
- Can be used jointly

# BRISC®

---

© 2014, SOPH GmbH, Hamburg, Germany

**ZIBTR d.o.o.**

**Tel.: 01 896 22 80**

**Fax: 01 896 22 82**

**Splet: [www.zibtr.com](http://www.zibtr.com)**

**E-pošta: [zibtr@siol.net](mailto:zibtr@siol.net)**

