



# DK (DIN 2080) A - AD Werkzeugaufnahmen

Toolholders

Porte-outils

Takım Tutucular

## INHALTSVERZEICHNIS / INDEX

Seite / Page

<b>Spannzangenfutter - Collet chuck</b> Mandrin à pinces - Pens başlığı	9.02-9.03
<b>Kraftspannfutter - Power milling chuck</b> Mandrin de fraisage - Bilyalı pens tutucu	9.04
<b>Fräseraufnahmen - End mill holder</b> Porte-fraises - Veldon tutucu	9.05
<b>Zwischenhülsen - Morse taper adapter</b> Douilles intermédiaires - Mors adaptörü	9.06-9.07
<b>Reduzierhülsen - Reduction sleeves</b> Douilles de réduction - Redüksiyon	9.07
<b>Kombi-Aufsteckfräserdorne - Combi shell mill holder</b> Porte-fraises à double usage pour fraises - Kombine malafa	9.08
<b>Quernut-Aufsteckdorne - Shell mill holder</b> Porte-fraises à surfacer - Alın kamalı malafa	9.09
<b>Bohrfutteraufnahme - Drill chuck</b> Arbre pour mandrin de perçage - Mandren malafası	9.10
<b>NC Bohrfutter - NC drill chuck</b> Mandrin de perçage - NC mandren malafası	9.10
<b>Gewindeschneidfutter - Quick change tapping chuck</b> Appareil à tarauder - Kılavuz çekme başlığı	9.11
<b>Rohlinge - Boring bar blanks</b> Barre d'alésage - Özel takım yapma amaçlı yarı mamul	9.11
<b>Kontrolldorne - Test arbors</b> Mandrin de contrôle - Kontrol mastarı	9.12

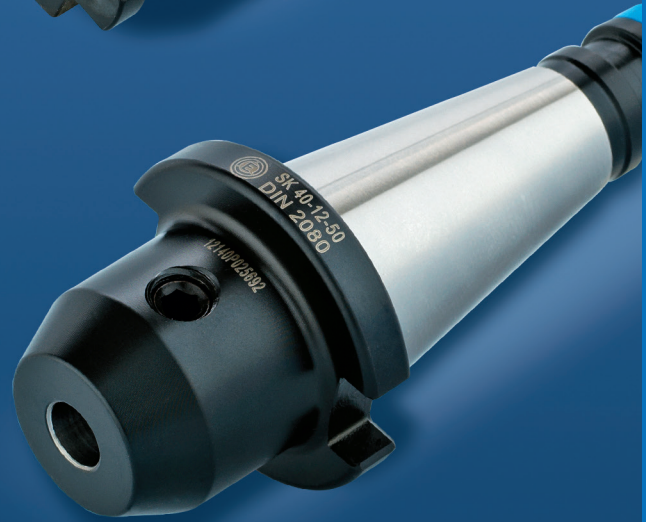
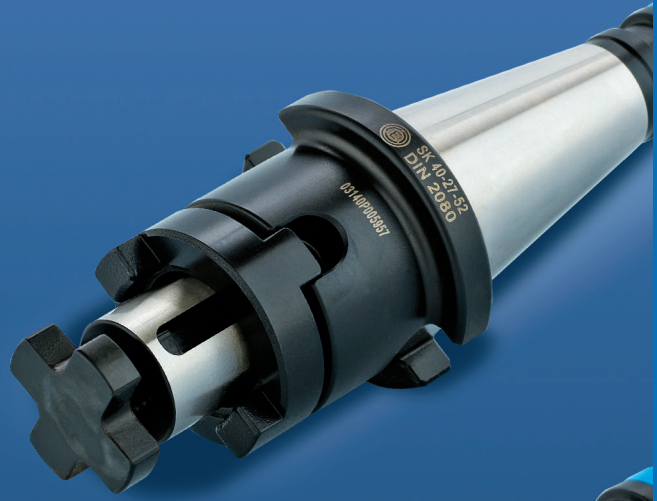



Toolholders

Porte-outils

Konik Şaft Ölçüleri

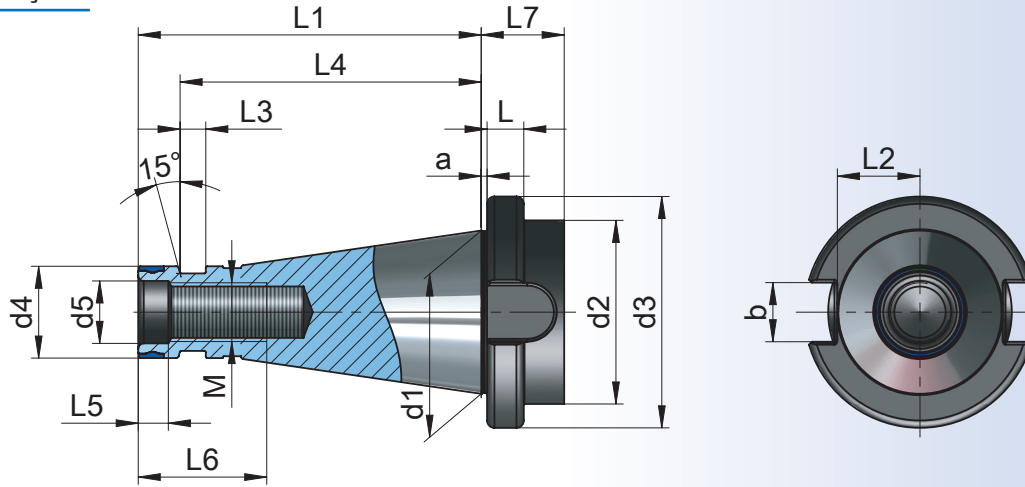

- ★ Mit Kunststoff-Kantenschutzring, Ringnut
- ★ Corner Protection with Ring, with slot
- ★ Protection d'angle avec anneau, avec slot
- ★ Plastik Köşe Koruma Ringli, Çektirme Kanallı

DK	d1	a	M	L6	d3	L	d2	L7	L1	d4	d5	L5	b	L2	L3	L4
30	31,75	1,6	M12	24	50	8	36	18,7	68,4	17,11	13	5,5	16,1	16		
40	44,45	1,6	M16	35	63	10	50	22,6	93,4	25	17	8,2	16,1	22,5	7	82
50	69,85	3,2	M24	50	97,5	12	78	31,2	126,8	39,3	26	11,5	25,7	35		

**Werkstoff** : Legierter Einsatzstahl mit einer Zugfestigkeit im Kern von min. 950 N/mm<sup>2</sup>

**Ausführung** : Einsatzgehärtet HRC 58 ± 2 Härtetiefe 0,6 mm + 0,2 mm, brüniert

**Genauigkeit** : Kegelwinkel-Toleranzqualität AT 3 nach DIN 2080  
Oberflächenrauigkeit des Kegels Ra 0,2

**Material** : Case hardened steel, tensile strength in the core min. 950 N/mm<sup>2</sup>

**Execution** : Case hardened HRC 58 ± 2 Depth of case 0,6 mm + 0,2 mm, black-finish

**Accuracy** : Cone angle AT 3 according DIN 2080  
Surface roughness of cone Ra 0,2

**Matière** : Châssis d'allié en acier de cémentation. Resistance à la traction dans le noyau de min 950 N/mm<sup>2</sup>

**Exécution** : Cémenté HRC 58 ± 2 Epaisseur de cémentation 0,6 mm + 0,2 mm Bruni

**Précision** : Qualité de finition pour l'angle des cône AT 3 suivant DIN 2080  
Rugosité en surface du cône Ra 0,2

**Malzeme** : Alaşımlı semente çeliği çekme mukavemeti min. 950 N/mm<sup>2</sup>

**Teknik özelliği**: Sertlik HRC ± 2 sertlik derinliği 0,6 mm + 0,2 mm, karartılmış

**Hassasiyeti** : Konik açı tolerans kalitesi DIN 2080  
Konik yüzey kalitesi Ra 0,2



## Spannfutter OZ

### Collet chucks OZ

### Mandrin à pincés OZ

### Pens başlığı OZ



Bestell-Nr. Order Nr. Reference Sipariş Nr.	DK	Form	Abmessung Size Dimension Cinsi	Spannbereich Capacity Capacité Kapasite	A	D	L2	Kg	Euro
301.01.16.50	DK 30	AD	OZ 16	415 E (2-16)	50	43	51	0,50	
301.01.25.80	DK 30	AD	OZ 25	462 E (2-25)	80	60	64	1,04	
401.01.16.55	DK 40	AD	OZ 16	415 E (2-16)	55	43	51	0,98	
401.01.25.66	DK 40	AD	OZ 25	462 E (2-25)	66	60	64	1,38	
401.01.32.95	DK 40	AD	OZ 32	467 E (4-32)	95	72	74	2,06	
501.01.25.71	DK 50	AD	OZ 25	462 E (2-25)	71	60	64	3,32	
501.01.32.73	DK 50	AD	OZ 32	467 E (4-32)	73	72	74	3,56	

FORM AD

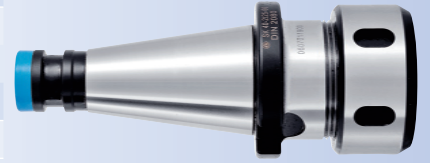
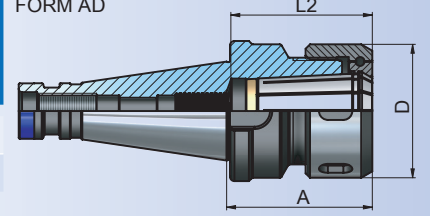

### Zubehör / Accessories / Accessoires / Yedekler

 DIN ISO 10897 10.08 - 10.10	Spannzangen OZ Collets OZ Pincés de serrage OZ Pens OZ	 DIN ISO 10897 10.24 + 10.26	Spannmutter OZ Clamping nuts OZ Écrou de serrage OZ Pens kapağı OZ	 DIN 1810 A 10.46	Hakenschlüssel Wrench Clé à ergot E tipi ay anahtar
---	---	---	---	--	--

## Spannfuttersatz im Koffer

### Collet chuck set in box

### Mandrin à pincés pour pincés (set) dans coffre

### Pens başlığı seti plastik kutuda



Bestell-Nr. Order Nr. Reference Sipariş Nr.	DK	Form	Abmessung Size Dimension Cinsi	Spannbereich Capacity Capacité Kapasite	Spannzangen Durchmesser Collet Diameter Pincés Diamètre Pens Çapı	Spannzangen Stk. Collet Pcs. Pincés Pens Adedi	Kg	Euro
401.61.25.66	DK 40	AD	OZ 25	462 E (2-25)	4-5-6-7-8-9-10-11-12-14-16-18-20-22-24-25	16	5,65	
401.61.32.95	DK 40	AD	OZ 32	467 E (4-32)	6-7-8-9-10-12-14-16-18-20-22-24-25-28-30-32	16	9,23	
501.61.25.71	DK 50	AD	OZ 25	462 E (2-25)	4-5-6-7-8-9-10-11-12-14-16-18-20-22-24-25	16	7,84	
501.61.32.73	DK 50	AD	OZ 32	467 E (4-32)	6-7-8-9-10-12-14-16-18-20-22-24-25-28-30-32	16	10,73	

Lieferumfang : Spannfutter, inkl. Spannzangen mit Schlüssel  
Included : Collet chuck with collets and wrench  
Inclus : Mandrin avec pincés et clé  
Teslim Şekli : Tutucu, pensleri ve anahtarıyla birlikte

### Zubehör / Accessories / Accessoires / Yedekler

 DIN ISO 10897 10.08 - 10.10	Spannzangen OZ Collets OZ Pincés de serrage OZ Pens OZ	 DIN ISO 10897 10.24 + 10.26	Spannmutter OZ Clamping nuts OZ Écrou de serrage OZ Pens kapağı OZ	 DIN 1810 A 10.46	Hakenschlüssel Wrench Clé à ergot E tipi ay anahtar
---	---	---	---	--	--





## Spannfutter ER

### Collet chucks ER

### Mandrin à pinces ER

### Pens başlığı ER

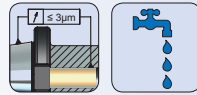

Bestell-Nr. Order Nr. Reference Sipariş Nr.	DK	Form	Spannbereich Capacity Capacité Kapasite	A	D	L2	Kg	Euro
301.02.16.50	DK 30	AD	ER25 (2 - 16)	50	42	42	0,50	
301.02.20.50	DK 30	AD	ER32 (2 - 20)	50	50	48	0,51	
401.02.10.50	DK 40	AD	ER16 (1 - 10)	50	28	32	0,85	
401.02.16.50	DK 40	AD	ER25 (2 - 16)	50	42	42	0,93	
401.02.20.50	DK 40	AD	ER32 (2 - 20)	50	50	48	0,96	
401.02.26.80	DK 40	AD	ER40 (3 - 26)	80	63	55	1,75	
501.02.20.63	DK 50	AD	ER32 (2 - 20)	63	50	48	2,99	
501.02.26.63	DK 50	AD	ER40 (3 - 26)	63	63	55	3,18	

FORM AD

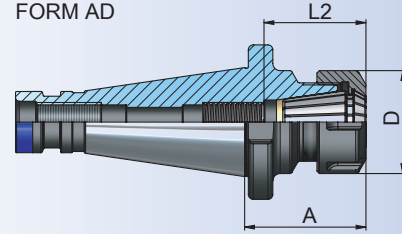

ER 16

### Zubehör / Accessories / Accessoires / Yedekler



Spannzangen System ER  
Collets System ER  
Pincés de serrage System ER  
Pens ER



Spannmutter ER  
Clamping nuts ER  
Écrou de serrage ER  
Pens kapağı ER



Spannschlüssel für ER  
Wrench ER  
Clé de serrage ER  
Anahtar ER



## Präzisionskraftspannfuttersatz im Koffer

### Precision milling chuck set in box

### Mandrin de fraisage de précision dans le box

### Pens başlığı pens seti plastik kutuda



Bestell-Nr. Order Nr. Reference Sipariş Nr.	DK	Form	Spannbereich Capacity Capacité Kapasite	Spannzangen Durchmesser Collet Diameter Pincés Diamètre Pens Çapı	Spannzangen Stk. Collet Pcs. Pincés Pens Adedi	Kg	Euro
401.62.16.50	DK 40	AD	ER25 (2 - 16)	3-4-5-6-7-8-9-10-11-12-14-16	12	2,45	
401.62.20.50	DK 40	AD	ER32 (2 - 20)	4-5-6-7-8-9-10-11-12-13-14-15-16-18-20	15	4,21	
401.62.26.80	DK 40	AD	ER40 (3 - 26)	4-5-6-7-8-9-10-12-14-16-18-20-22-24-25-26	16	7,05	
501.62.20.63	DK 50	AD	ER32 (2 - 20)	4-5-6-7-8-9-10-11-12-13-14-15-16-18-20	15	7,33	
501.62.26.63	DK 50	AD	ER40 (3 - 26)	4-5-6-7-8-9-10-12-14-16-18-20-22-24-25-26	16	8,74	

Lieferumfang : Spannfutter, inkl. Spannzangen mit Schlüssel  
Included : Collet chuck with collets and wrench  
Inclus : Mandrin avec pincés et clé  
Teslim Şekli : Tutucu, pensleri ve anahtarlarıyla birlikte

### Zubehör / Accessories / Accessoires / Yedekler



Spannzangen System ER  
Collets System ER  
Pincés de serrage System ER  
Pens ER



Spannmutter ER  
Clamping nuts ER  
Écrou de serrage ER  
Pens kapağı ER



Spannschlüssel für ER  
Wrench ER  
Clé de serrage ER  
Anahtar ER





## Präzisionskraftspannfutter

### Precision milling chuck

### Mandrin de fraisage de précision

### Bilyalı pens tutucu

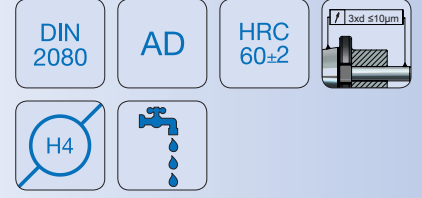

Bestell-Nr. Order Nr. Reference Sipariş Nr.	DK	Form	Spannbereich Capacity Capacité Kapasite	d	A	D	L2	Kg	Euro
401.03.20.65.N	DK 40	AD	EKS 20 (6-20)	20	65	48	80	1,21	
401.03.32.75.N	DK 40	AD	EKS 32 (6-32)	32	75	68	80	1,79	
501.03.20.70.N	DK 50	AD	EKS 20 (6-20)	20	70	48	80	3,11	
501.03.32.75.N	DK 50	AD	EKS 32 (6-32)	32	75	68	80	3,58	

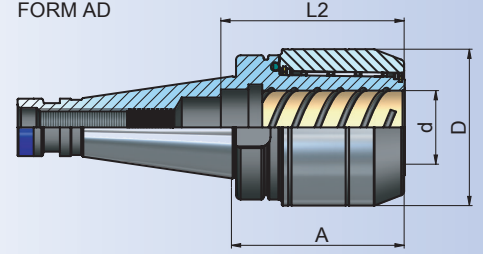

## Präzisionskraftspannfuttersatz im Koffer

### Precision milling chuck set in box

### Mandrin de fraisage de précision dans le box

### Bilyalı pens tutucu seti plastik kutuda



Bestell-Nr. Order Nr. Reference Sipariş Nr.	DK	Form	Spannbereich Capacity Capacité Kapasite	Spannzangen Durchmesser Collet Diameter Pincas Diamètre Pens Çapı	Spannzangen Stk. Collet Pcs. Pincas Pens Adedi	Kg	Euro
401.63.20.65.N	DK 40	AD	EKS 20 (6-20)	6-8-10-12-16	5	2,94	
401.63.32.75.N	DK 40	AD	EKS 32 (6-32)	6-8-10-12-16-20-25	7	5,36	
501.63.20.70.N	DK 50	AD	EKS 20 (6-20)	6-8-10-12-16	5	6,48	
501.63.32.75.N	DK 50	AD	EKS 32 (6-32)	6-8-10-12-16-20-25	7	8,16	

Lieferumfang : Spannfüter, inkl. Spannzangen mit Schlüssel

Included : Collet chuck with collets and wrench

Inclus : Mandrin avec pincas et clé

Teslim Şekli : Tutucu, pensleri ve anahtarıyla birlikte

### Zubehör / Accessories / Accessoires / Yedekler



Spannzangen  
Collets  
Pincas de serrage  
Pens

10.19



Rollenschlüssel für Spannmutter  
Roller Bearing Wrenches  
Cles à rouleaux  
Bilyalı Kapak Sıkma Anahtarı

10.47



11.02



## Fräseraufnahmen



### End mill holder

### Porte-fraises

### Veldon tutucu

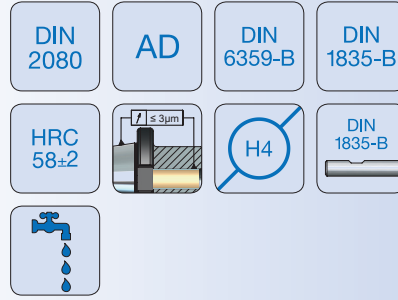

Bestell-Nr. Order Nr. Reference Sipariş Nr.	DK	Form	d	A	D	L2	Kg	Euro
301.04.06.40	DK 30	AD	6	40	25	36	0,39	
301.04.08.40	DK 30	AD	8	40	28	40	0,42	
301.04.10.40	DK 30	AD	10	40	35	44	0,48	
301.04.12.40	DK 30	AD	12	40	42	51	0,54	
301.04.14.50	DK 30	AD	14	40	44	51	0,67	
301.04.16.50	DK 30	AD	16	50	48	54	0,73	
301.04.18.50	DK 30	AD	18	50	50	54	0,75	
301.04.20.63	DK 30	AD	20	63	52	56	0,97	

401.04.06.50	DK 40	AD	6	50	25	36	0,87	
401.04.08.50	DK 40	AD	8	50	28	40	0,91	
401.04.10.50	DK 40	AD	10	50	35	44	0,97	
401.04.12.50	DK 40	AD	12	50	42	51	1,07	
401.04.14.50	DK 40	AD	14	50	44	51	1,09	
401.04.16.63	DK 40	AD	16	63	48	54	1,32	
401.04.18.63	DK 40	AD	18	63	50	54	1,36	
401.04.20.63	DK 40	AD	20	63	52	56	1,38	
401.04.25.80	DK 40	AD	25	80	63	64	2,04	
401.04.32.80	DK 40	AD	32	80	72	68	2,34	
401.04.40.90	DK 40	AD	40	90	80	78	2,83	

501.04.06.63	DK 50	AD	6	63	25	36	2,81	
501.04.08.63	DK 50	AD	8	63	28	40	2,85	
501.04.10.63	DK 50	AD	10	63	35	44	2,92	
501.04.12.63	DK 50	AD	12	63	42	51	3,05	
501.04.14.63	DK 50	AD	14	63	44	51	3,09	
501.04.16.63	DK 50	AD	16	63	48	54	3,17	
501.04.18.63	DK 50	AD	18	63	50	54	3,20	
501.04.20.63	DK 50	AD	20	63	52	56	3,23	
501.04.25.80	DK 50	AD	25	80	63	64	3,87	
501.04.32.80	DK 50	AD	32	80	72	68	4,17	
501.04.40.90	DK 50	AD	40	90	80	78	4,64	

FORM AD

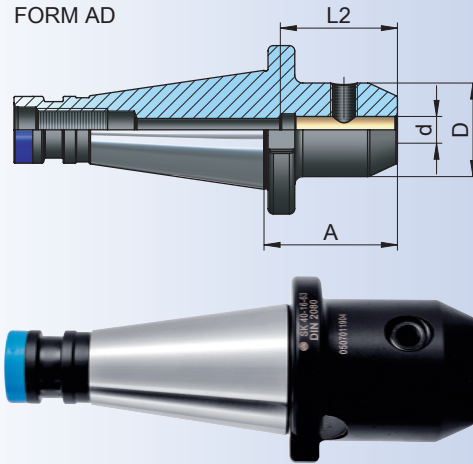

### Zubehör / Accessories / Accessoires / Yedekler



Spannschrauben  
Clamping screw  
Vis de serrage  
Sıkma civatası



11.05



## Morsekegel-Aufnahmen mit Austreibblappen

Morse taper adaptor

Douilles intermédiaires pour outils à cône Morse

Mors adaptörü

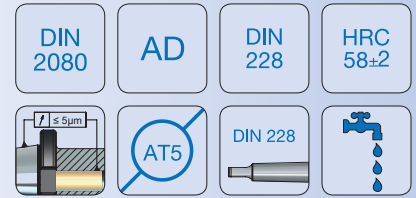

Bestell-Nr. Order Nr. Reference Sipariş Nr.	DK	Form	MK	A	D	Kg	Euro
301.07.01.50	DK 30	AD	MK 1	50	25	0,40	
301.07.02.50	DK 30	AD	MK 2	50	32	0,43	
301.07.03.75	DK 30	AD	MK 3	75	40	0,65	
401.07.01.50	DK 40	AD	MK 1	50	25	0,84	
401.07.02.50	DK 40	AD	MK 2	50	32	0,86	
401.07.03.65	DK 40	AD	MK 3	65	40	0,98	
401.07.04.95	DK 40	AD	MK 4	95	48	1,30	
501.07.01.45	DK 50	AD	MK 1	45	25	2,64	
501.07.02.60	DK 50	AD	MK 2	60	32	2,72	
501.07.03.65	DK 50	AD	MK 3	65	40	2,77	
501.07.04.70	DK 50	AD	MK 4	70	48	2,76	
501.07.05.105	DK 50	AD	MK 5	105	63	3,23	

FORM AD

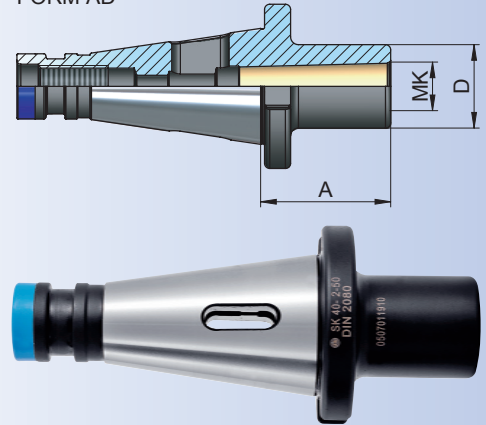





## Zwischenhülsen für MK mit Anzugsgewinde

Morse taper adaptor for tools with morse taper shank and drawbar thread

Douilles intermédiaires pour outils à cône Morse à trou fileté

Mors adaptörü çekirme civatalı

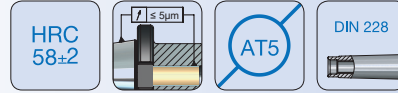

Bestell-Nr. Order Nr. Reference Sipariş Nr.	DK	Form	MK	A	D	Kg	Euro
401.08.01.50	DK 40	A	MK 1	50	25	0,88	
401.08.02.50	DK 40	A	MK 2	50	32	0,91	
401.08.03.65	DK 40	A	MK 3	65	40	1,05	
401.08.04.95	DK 40	A	MK 4	95	48	1,42	
*401.08.04A.110	DK 40	A	MK 4	110	63	2,42	
501.08.01.60	DK 50	A	MK 1	60	25	2,81	
501.08.02.60	DK 50	A	MK 2	60	32	2,84	
501.08.03.65	DK 50	A	MK 3	65	40	2,92	
501.08.04.65	DK 50	A	MK 4	65	48	2,88	
*501.08.04A.80	DK 50	A	MK 4	80	63	3,57	
501.08.05.120	DK 50	A	MK 5	120	63	3,83	
*501.08.05A.138	DK 50	A	MK 5	138	78	5,45	

\* Mit Mitnahmeausfräsung nach DIN 2201

\* With driving facilities to DIN 2201

\* Avec douille d'accouplement de fraisure DIN 2201

\* Taşıyıcı yuvalı DIN 2201

FORM A

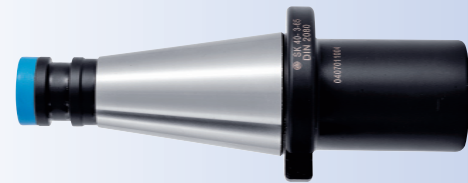
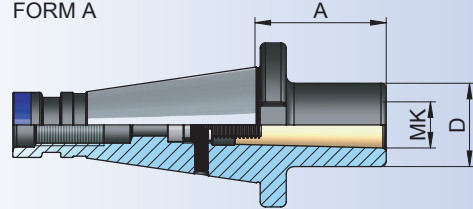

## Adapter / Reduzierungen

Reduction Sleeves

Douilles de réduction

Çektirme civatalı redüksiyon

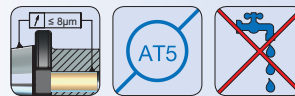

Bestell-Nr. Order Nr. Reference Sipariş Nr.	DK	Form	SK <sub>1</sub>	A	D	Kg	Euro
401.09.30.50	DK 40	A	SK 30	50	50	1,14	
401.09.40.100	DK 40	A	SK 40	100	63	2,31	
501.09.40.50	DK 50	A	SK 40	50	70	3,22	
501.09.50.125	DK 50	A	SK 50	125	97	6,64	

FORM A

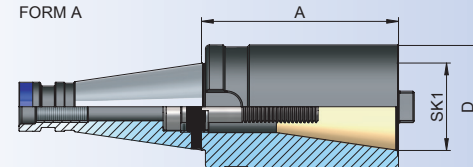

DK (DIN 2080)



## Kombi - Aufsteckfräserdorne

### Combi shell mill holder

Porte-fraises á double usage pour fraises á entraînement par clavette ou tenon

Kombine malafa

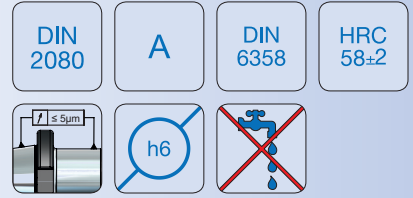

Bestell-Nr. Order Nr. Reference Sipariş Nr.	DK	Form	d	A	D	L3	L4	Kg	Euro
301.10.16.35	DK 30	A	16	35	32	17	27	0,50	
301.10.22.35	DK 30	A	22	35	40	19	31	0,62	
301.10.27.35	DK 30	A	27	35	48	21	33	0,77	
301.10.32.50	DK 30	A	32	50	58	24	38	1,30	
401.10.16.52	DK 40	A	16	52	32	17	27	1,06	
401.10.22.52	DK 40	A	22	52	40	19	31	1,24	
401.10.27.52	DK 40	A	27	52	48	21	33	1,46	
401.10.32.52	DK 40	A	32	52	58	24	38	1,78	
401.10.40.52	DK 40	A	40	52	70	27	41	2,28	
501.10.16.55	DK 50	A	16	55	32	17	27	2,97	
501.10.22.55	DK 50	A	22	55	40	19	31	3,14	
501.10.27.55	DK 50	A	27	55	48	21	33	3,37	
501.10.32.55	DK 50	A	32	55	58	24	38	3,69	
501.10.40.55	DK 50	A	40	55	70	27	41	4,21	

FORM A

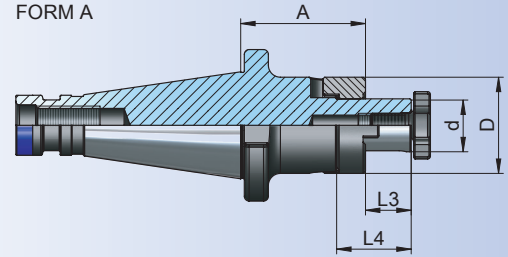

### Zubehör / Accessories / Accessoires / Yedekler

DIN 6366



10.46

Mitnehmerringe  
Clutch drive rings to  
Bague d'entraînement  
Tirnaklı pul

DIN 6367



10.45

Fräseranzugsschrauben  
Drawn in bolt  
Vis de serrage  
Alın sıkma civatası

DIN 6885



10.44

Paßfeder  
Drive key  
Ressort de passage  
Kama

DIN 6388



10.46

Spannschlüssel für Aufsteckdorne  
Wrench  
Clé de serrage  
Alın civatası sıkma anahtarı

## Quernut-Aufsteckdorne mit vergrößertem Bunddurchmesser



Shell mill holder for cutters with driving slot

Porte-fraises à surfacer avec diamètre de collerette élargi

Alın kamalı malafa

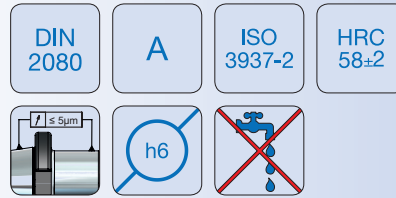

Bestell-Nr. Order Nr. Reference Sipariş Nr.	DK	Form	d	A	D	L3	Kg	Euro
401.11.16.30	DK 40	A	16	30	38	17	0,98	
401.11.22.30	DK 40	A	22	30	48	19	1,12	
401.11.27.30	DK 40	A	27	30	60	21	1,31	
401.11.32.50	DK 40	A	32	50	78	24	2,22	
*401.11.40.50	DK 40	A	40	50	88	27	2,57	
501.11.22.35	DK 50	A	22	35	48	19	3,05	
501.11.27.35	DK 50	A	27	35	60	21	3,26	
501.11.32.40	DK 50	A	32	40	78	24	3,83	
*501.11.40.55	DK 50	A	40	55	88	27	3,84	
*501.11.60.55	DK 50	A	60	55	128	40	6,67	

FORM A

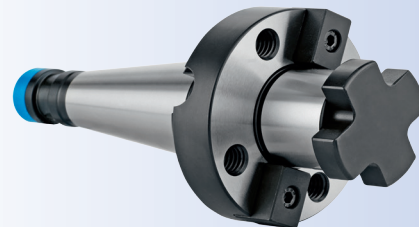
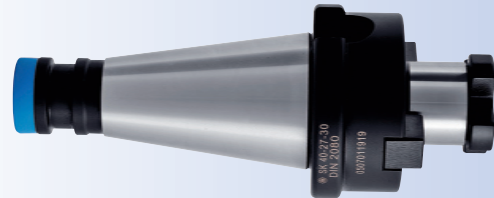
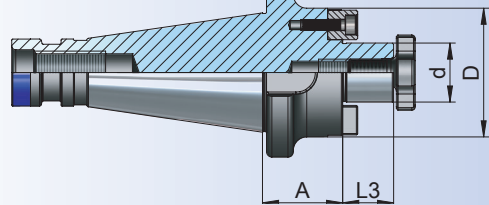

\* d=Ø 40 (M12) \* d=Ø 60 (M16)

Mit zusätzlichen 4 Gewindebohrungen nach DIN 2079  
With additional 4 screws holes in compliance with DIN 2079  
Avec 4 trous taraudés supplémentaires d'après DIN 2079  
DIN 2079 'a uygun ilave 4 vida bağlantılı

### Zubehör / Accessories / Accessoires / Yedekler

DIN 6367



10.45

Fräseranzugsschrauben  
Drawn in bolt  
Vis de serrage  
Alın sıkma civatası

10.44



Mitnehmersteine  
Drive keys  
Entraîneur  
Kama

DIN 6368



10.46

Spannschlüssel für Aufsteckdorne  
Wrench  
Clé de serrage  
Alın civatası sıkma anahtarı



## Bohrfutteraufnahme

### Drill chuck adaptor

### Arbre pour mandrin de perçage

### Mandren malafası



Bestell-Nr. Order Nr. Reference Sipariş Nr.	DK	Form	D1	A	L1	Kg	Euro
301.14.12.15	DK 30	A	B12	15	18,5	0,33	
301.14.16.16	DK 30	A	B16	16	24	0,36	
401.14.12.17	DK 40	A	B12	17	18,5	0,80	
401.14.16.18	DK 40	A	B16	18	24	0,82	
401.14.18.18	DK 40	A	B18	18	32	0,84	
501.14.16.22	DK 50	A	B16	22	24	2,73	
501.14.18.22	DK 50	A	B18	22	32	2,75	

FORM A

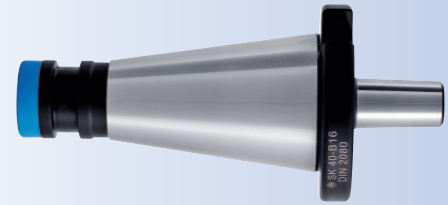
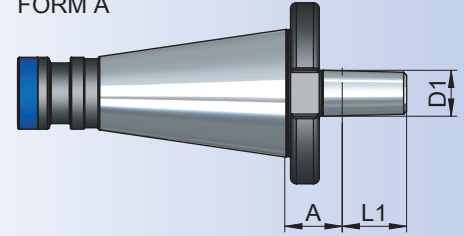

### Zubehör / Accessories / Accessoires / Yedekler



Bohrfutter  
Drill chuck  
Mandrin de perçage à serrage rapide  
Mandren

## NC - Bohrfutter für Rechts - und Linkslauf

### NC-Drill chucks for left and right rotation

### Mandrin de perçage CNC pour rotation gauche-droite

### NC tipi mandren malafası komple sağ ve sol dönüşlü

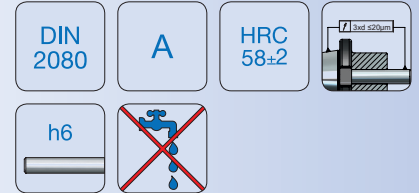

Bestell-Nr. Order Nr. Reference Sipariş Nr.	DK	Form	Spannbereich Capacity Capacité Kapasite	A	D	A1 Max.	Kg	Euro
301.15.08.60	DK 30	A	0,5 - 8	60	36	63	0,71	
301.15.13.90	DK 30	A	1,0 - 13	90	50	98	1,32	
401.15.08.62	DK 40	A	0,5 - 8	62	36	65	1,08	
401.15.13.84	DK 40	A	1,0 - 13	84	50	92	1,63	
401.15.16.89	DK 40	A	3,0 - 16	89	57	94	1,86	
501.15.13.86	DK 50	A	1,0 - 13	86	50	92	3,58	
501.15.16.91	DK 50	A	3,0 - 16	91	57	96	3,82	

FORM A

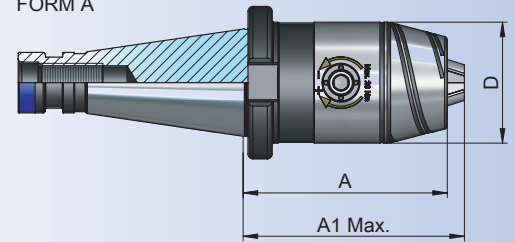

### Zubehör / Accessories / Accessoires / Yedekler



Ersatzteile  
Spare Parts  
Pièce de rechange  
Yedek parçalar



Spannschlüssel  
Wrench  
Clé de serrage  
Sıkma anahtarı



## Gewindeschneid - Schnellwechselfutter mit Längenausgleich auf Druck und Zug



### Quick-change tapping chucks with length compensation

### Appareil à tarauder avec compensation longitudinale

### Kılavuz çekme başlığı giriş ve çıkış kompanzeli



Bestell-Nr. Order Nr. Reference Sipariş Nr.	DK	Form	Spannbereich Capacity Capacité Kapasite	d	A	D	C	T	Kg	Euro
301.16.12.61	DK 30	A	M2-M14	19	61	36,5	7	7	0,63	
301.16.20.92	DK 30	A	M5-M24	31	92	53,5	12	12	1,26	
401.16.12.61	DK 40	A	M2-M14	19	61	36,5	7	7	1,01	
401.16.20.97	DK 40	A	M5-M24	31	97	53,5	12	12	1,66	
401.16.36.130	DK 40	A	M14-M36	48	130	78	17,5	17,5	3,32	
501.16.12.61	DK 50	A	M2-M14	19	61	36,5	7	7	2,76	
501.16.20.82	DK 50	A	M5-M24	31	82	53,5	12	12	3,21	
501.16.36.131	DK 50	A	M14-M36	48	131	78	17,5	17,5	5,21	

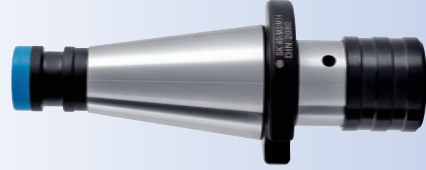
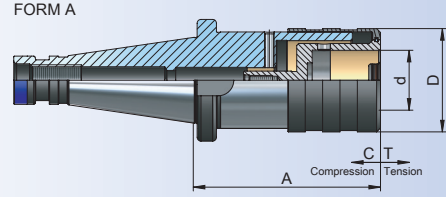

Ausführung : Mit Kugelführungsbuchse  
Version : With ball retainer  
Version : Comrenant douille de glissière à bille  
Teknik özelliği : Bilya Kafesli

### Zubehör / Accessories / Accessoires / Yedekler



Schnellwechseleinsätze  
Tapping collets  
Douilles de taraudage  
Kılavuz tutucu

## Rohlinge zur Anfertigung von Sonderwerkzeugen

### Boring bar blanks for the production of special tools

### Barre d'alésage pour la fabrication d'outils spéciaux

### Özel takım yapma amaçlı yarı mamul



Bestell-Nr. Order Nr. Reference Sipariş Nr.	DK	Form	D	A	Kg	Euro
401.17.63.250	DK 40	A	63	250	6,46	
501.17.97.315	DK 50	A	97	315	19,61	

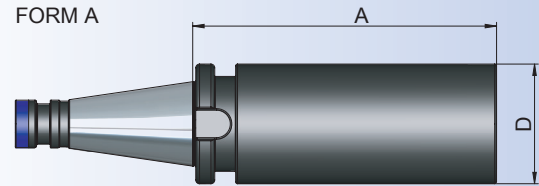

Ausführung : Steilkegel und Bund gehärtet (52±2 HRC) und geschliffen, Schaft weich zur weiteren Bearbeitung.  
Version : Cone and flange hardened (52±2 HRC) and grinded. Soft body for later processing.  
Version : Cône et collerette durcir (52±2 HRC) et rectifiés. Corps doux pour un usinage ultérieur.  
Teknik özelliği : Konik ve Flanş kısmı sertleştirilmiş (52±2 HRC) ve taşlanmıştır. Bara kısmı işlenebilir yumuşaktır.



## Kontrollidorne

### Test arbors

### Mandrins de contrôle

### Fener mili kontrol mastarı

DIN  
2080

A

HRC  
58±2

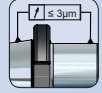

Bestell-Nr. Order Nr. Reference Sipariş Nr.	DK	Form	D	A	Kg	Euro
301.18.32.200	DK 30	A	32	200	1,44	
401.18.40.300	DK 40	A	40	300	3,47	
501.18.50.300	DK 50	A	50	300	6,54	

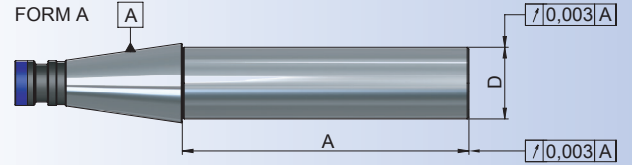

Verwendung : Zur Abnahme von Werkzeugmaschinen  
gemäß ISO-Empfehlung R230

Application : For acceptance tests of machine tools  
in accordance with ISO-recommendation R230

Application : Pour la recette technique des machines  
conforme recommandation ISO R230

Açıklama : Tezgahları devreye alırken ISO Normu R230  
sisteminde uygunluğunu kontrol etmek için