



Angetriebene Werkzeuge

Driven Tools

Porte-outils motorise

Tahrikli Takım Tutucular

INHALTSVERZEICHNIS / INDEX	Seite / Page
Baruffaldi TOEM	6.01 - 6.05
Diplomatic DIN 1809	6.06 - 6.10
Sauter - Revolver DIN 5480	6.11 - 6.15
Sauter - Revolver DIN 5482	6.16 - 6.20
Mori Seiki BMT32	6.21
Miyano BMT45	6.22
Mori Seiki BMT40 / BMT60	6.23 - 6.24
BMT 45-55-65-75	6.25 - 6.26
Mazak Nexus 200 - 250	6.27
Mazak Nexus 300 - 350	6.28
Mazak Nexus 100 MY	6.29
Mazak MP 420/620/625/6200/6250	6.30
Okuma	6.31 - 6.33
Okuma LT 300 M	6.34
Okuma LB 2000 / 2500 / 3000	6.35
Okuma LB 4000	6.36
Okuma LT 2000 EX V16	6.37
Takisawa EX 308 / 310 / 508 / 510	6.38
Takisawa TY200	6.39
Takisawa TC250	6.40
Takisawa TS4000Y	6.41
HAAS SL20 - SL40	6.42 - 6.46
Nakamura BMT55	6.47
Tsugami M06SY / M08SY	6.48 - 6.49





Sternrevolver

Tourelle de L'étoile

Star Tourelle

Yıldız Taret

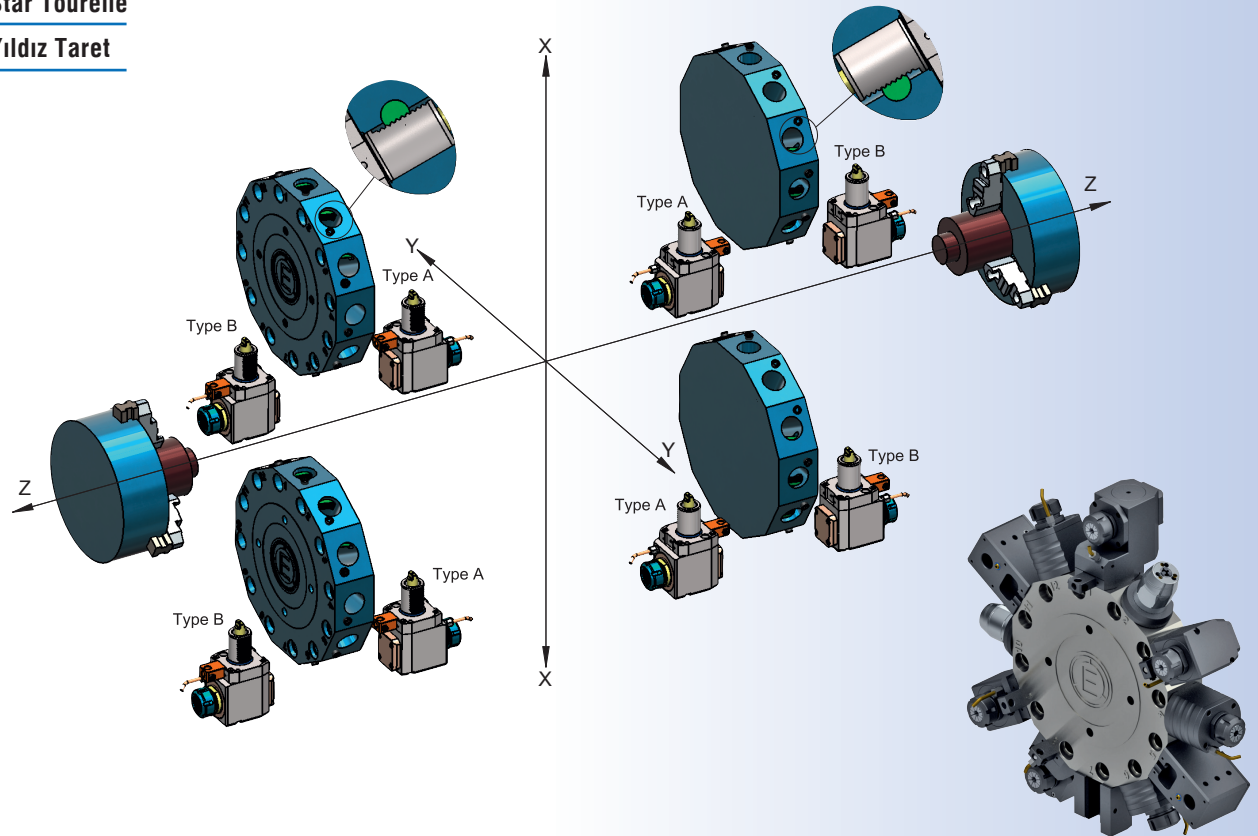

Scheibenrevolver

Disk Turret

Tourelle de disque

Disk Taret

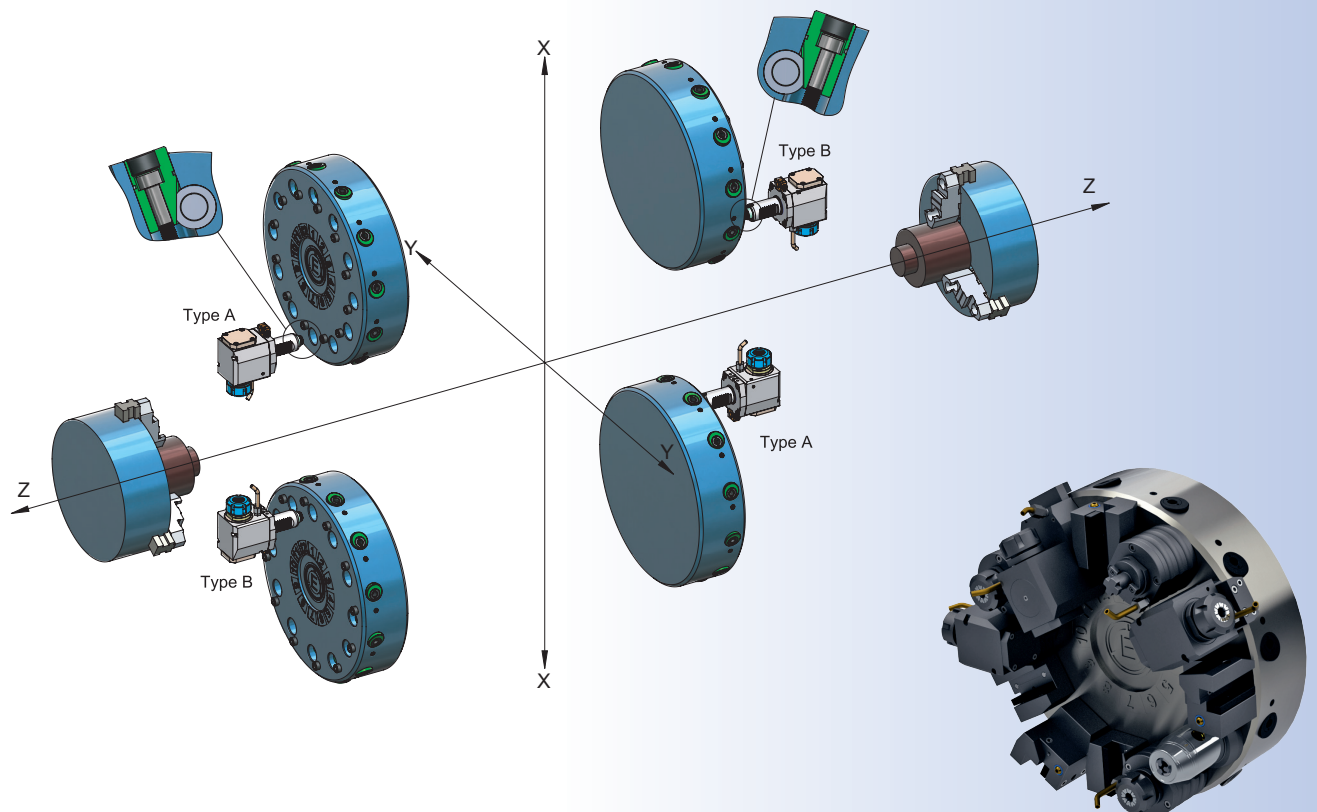



Kupplungstypen

Coupling Types

Types de Couplage

Kaplin Tipleri

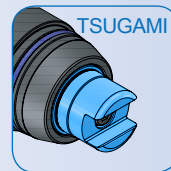
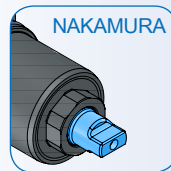
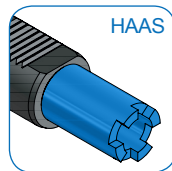
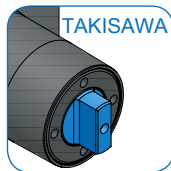
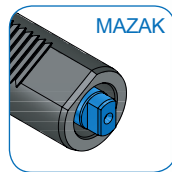
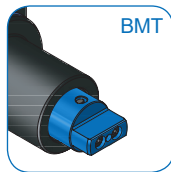
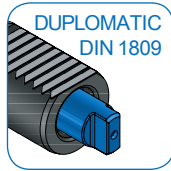
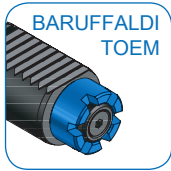

Technische Daten

- Dauerhafte Bearbeitungsperformance und Schneidleistung
- Nullpunktjustierung somit kurze Einstellzeit
- Optimale Dichtigkeit mit speziellem Walzenöl. Wartungsarm, längere Lebensdauer der eingesetzten Werkzeuge
- maximale Kraftübertragung durch ausgewählte Zahnräder
- Externes Kühlungssystem
- Rundlaufgenauigkeit $\leq 0,01$ mm
- Schaft gemäß DIN ISO 10889 (DIN 69880)
- Achsenparallelität $\leq 0,02$ mm
- EROGLU Qualitätsgarantie.

Technical Data

- Durable processing performance and cutting power
- Zero-point-adjustment and therefore short adjustment time
- Optimal density with special oil, longer life time of the used tools
- Maximum power transmission by selected gears
- External cooling system
- Concentricity accuracy $\leq 0,01$ mm
- Shank according to DIN ISO 10889 (DIN 69880)
- Axis parallelism $\leq 0,02$ mm
- EROGLU quality guarantee



Kuplungstypen

Coupling Types

Types de Couplage

Kaplin Tipleri

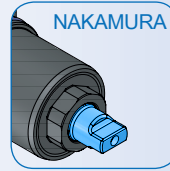
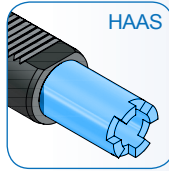
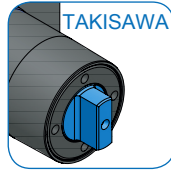
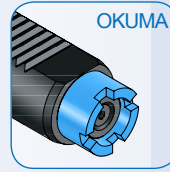
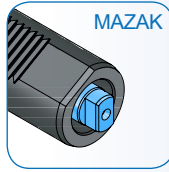
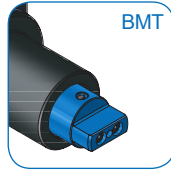
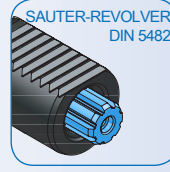
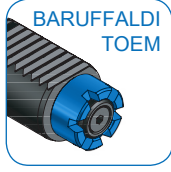

Données Techniques:

- Performance d'usinage stable
- Mise à zero rapide, gain de temps de réglage
- Etanchéité optimale. Durée de vie élevée traitement de surface spécifique.
- Transmission du couple par selections de pignons
- Arrosage externe
- Concentricité $\leq 0,01$ mm
- queue selon DIN ISO 10889 (DIN 69880)
- parallélisme des axes $\leq 0,02$ mm
- EROGLU garantie de qualité

Teknik Bilgi

- Güçlü spindle rulmanları sayesinde yüksek rijitlik ve mükemmel kesme performansı
- Geniş sıfırlama yüzeyi ve ayarlama civataları sayesinde doğru ve hızlı ayarlama imkanı
- Özel yağlar ve sızdırmazlık elemanları sayesinde uzun ömür ve uzun bakım periyotları
- Yüksek devirde çalışmaya müsait, taşlanmış dişli sayesinde sessiz, hassas çalışma ve yüksek tork iletimi
- Kesiciyi en iyi soğutacak şekilde ayarlanabilir dıştan soğutma sistemi
- Düşük salgı değerleri $\leq 0,01$ mm
- DIN ISO 10889 (DIN 69880) normuna ve tezgah özelliklerine tam uyum
- Hassas eksen paralellikleri $\leq 0,02$ mm
- EROGLU kalitesi ve güvencesiyle



Axial drilling - milling head collet chuck

Tête de perçage - fraisage axiale mandrin pour pinces

Axial Tahrikli Takım Tutucu Pens Başlığı

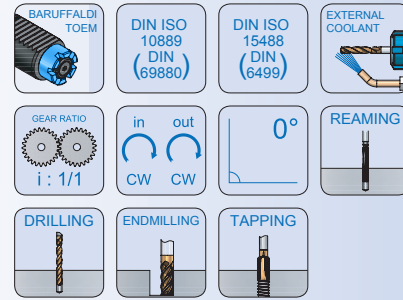
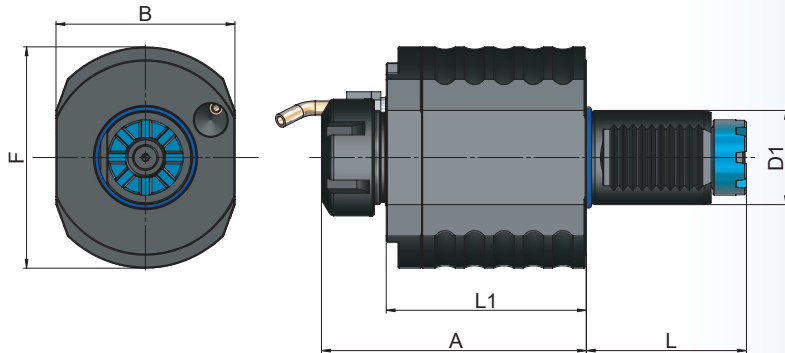

Bestell-Nr. Order Nr. Reference Sipariş Nr.	D1	Spannbereich Capacity Capacité Kapasite	A	L	L1	B	F	N.Max (1/min)	T.Max. (Nm)	Kg	Euro
TOAX30E25090	30	ER25 (2 - 16)	90	59	58	62	70	6000	25	1,90	
TOAX40E32112	40	ER32 (2 - 20)	112,5	68	76	76	94	6000	50	4,20	
TOAX40E40126	40	ER40 (3 - 26)	126,5	68	76	76	94	6000	50	4,45	
TOAX50E32117	50	ER32 (2 - 20)	117,5	84	80	88	102	5000	80	5,75	
TOAX50E40122	50	ER40 (3 - 26)	122	84	80	88	102	5000	80	5,95	

Zubehör / Accessories / Accessoires / Yedekler

DIN ISO 15488

 Spannzangen System ER
 Collets System ER
 Pincés de serrage System ER
 Pens ER
 10.11 - 10.18

DIN ISO 15488

 Spannmutter ER
 Clamping nuts ER
 Écrou de serrage ER
 Pens kapağı ER
 10.25 - 10.26

Spanschlüssel ER
 Wrench ER
 Clé de serrage
 Anahtar ER
 10.48

AA Schlüssel
 AA Wrench
 Clé AA
 AA Anahtar
 10.47



Axial milling head chuck for cutter arbor

Tetê de fraisage axiale porte - fraise

Axial Tahrikli Takım Tutucu Alın Kamalı Malafa



DIN ISO
10889
(DIN
69880)

ISO
3937

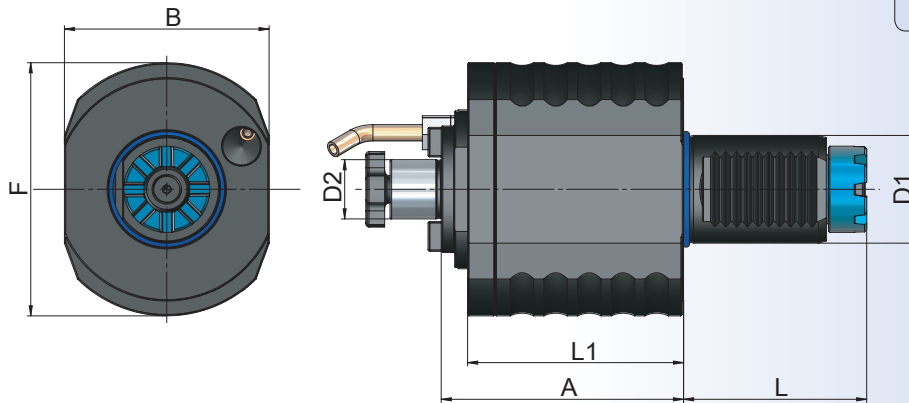

Bestell-Nr. Order Nr. Reference Sipariş Nr.	D1	D2	A	L	L1	B	F	N.Max (1/min)	T.Max. (Nm)	Kg	Euro
TOAX30K16071	30	16	71	59	58	62	70	6000	25	1,90	
TOAX40K16090	40	16	90	68	76	76	94	6000	50	4,20	
TOAX40K22090	40	22	90	68	76	76	94	6000	50	4,30	
TOAX50K22095	50	22	95	84	80	88	102	5000	80	5,85	
TOAX50K27095	50	27	95	84	80	88	102	5000	80	6,00	

Zubehör / Accessories / Accessoires / Yedekler

DIN 6367



Fräseranzugsschrauben
Drawn in bolt
Vis de serrage
Alın sıkma civatası

10.45



Mitnehmersteine
Drive keys
Entraîneur
Kama

10.44

DIN 6368



Spannschlüssel für Aufsteckdorne
Wrench
Clé de serrage
Alın civatası sıkma anahtar

10.46



Radial drilling - milling head collet chuck

Tête de perçage - fraiseage radiale mandrin pour pinces

Radial Tahrikli Takım Tutucu Pens Başlığı

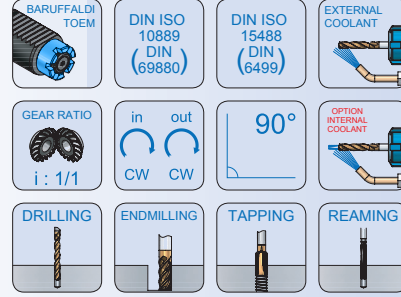
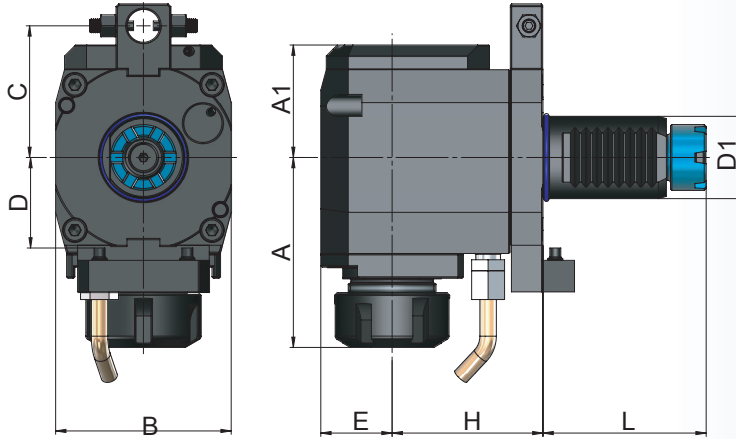

Bestell-Nr. Order Nr. Reference Sipariş Nr.	D1	Spannbereich Capacity Capacité Kapasite	A	A1	E	H	L	B	N.Max (1/min)	T.Max. (Nm)	Kg	Euro
TORA30E25A055	30	ER25 (2 - 16)	67	41	26	55	59	64	6000	25	2,95	
TORA30E25B055	30	ER25 (2 - 16)	67	41	26	55	59	64	6000	25	2,95	
TORA40E32A065	40	ER32 (2 - 20)	85	53	38	65	68	76	6000	50	5,55	
TORA40E32B065	40	ER32 (2 - 20)	85	53	38	65	68	76	6000	50	5,55	
TORA40E40A065	40	ER40 (3 - 26)	98	53	38	65	68	76	6000	50	6,00	
TORA40E40B065	40	ER40 (3 - 26)	98	53	38	65	68	76	6000	50	6,00	
TORA50E32A075	50	ER32 (2 - 20)	92,5	60	44	75	84	88	5000	80		
TORA50E32B075	50	ER32 (2 - 20)	92,5	60	44	75	84	88	5000	80		
TORA50E40A075	50	ER40 (3 - 26)	98,5	60	44	75	84	88	5000	80	8,70	
TORA50E40B075	50	ER40 (3 - 26)	98,5	60	44	75	84	88	5000	80	8,70	

	VDI 30	VDI 40	VDI 50
C40	X		
C47	X		
C48	X		
C56	X	X	
C63	X	X	X
C64			X
C70		X	X
C90		X	

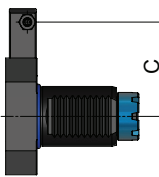

	VDI 30	VDI 40	VDI 50
D35	X		
D42		X	
D48		X	
D50		X	
D55	X		
D56		X	
D63		X	

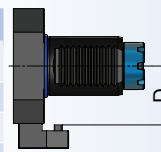

Interne Kühlmittelzufuhr kann als Option bestellt werden.
(Beispiel Bestellnummer: TORA40E32A065C63IK)

Internal coolant supply can be ordered as option.
(Example order number: TORA40E32A065C63IK)

L'alimentation interne en liquide de refroidissement
peut être commandée en option.
(Exemple numéro de commande: TORA40E32A065C63IK)

İsteğe bağlı içten su vermeli sipariş edilebilir.
(Örnek Sipariş Nr.: TORA40E32A065C63IK)

Achtung: Die Lieferung erfolgt mit montage arretierungsklötze! Bitte geben sie C und D masse.
(Beispiel Bestellnummer: TORA30E25A055C40 oder TORA30E25A055D35)

Attention: The delivery takes place with assembly lock blocks! Please give C or D dimensions.
(Example order code no.: TORA30E25A055C40 or TORA30E25A055D35)

Attention: La livraison a lieu avec des blocs de verrouillage d'assemblage! Veuillez donner les dimensions C et D.
(Exemple commande no.: TORA30E25A055C40 ou TORA30E25A055D35)

Dikkat: Teslimat referans kaması veya dayaması ile gerçekleşir! Lütfen C veya D boyutlarını verin.
(Örnek Sipariş Nr.: TORA30E25A055C40 veya TORA30E25A055D35)

Zubehör / Accessories / Accessoires / Yedekler

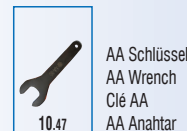
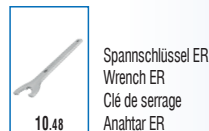



Radial drilling - milling head collet chuck - shifted

Tête de perçage - fraisage radiale mandrin pour pinces - décalé

Radial Tahrikli Takım Tutucu Pens Başlığı - Eksenden Kaçığı

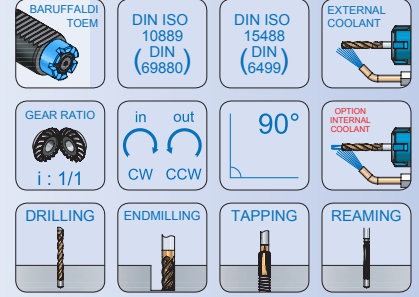
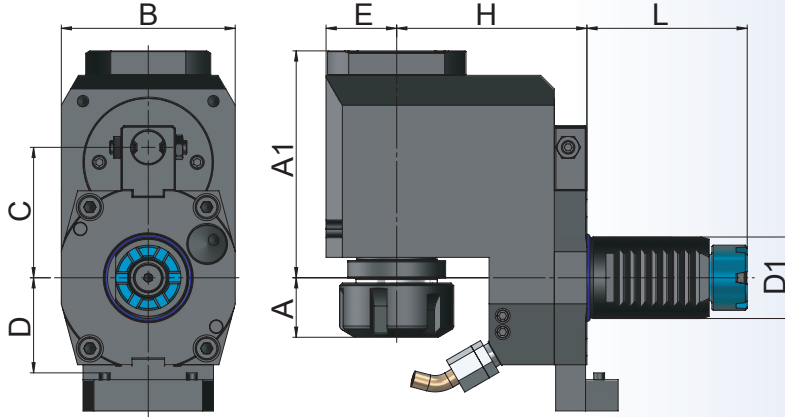

Bestell-Nr. Order Nr. Reference Sipariş Nr.	D1	Spannbereich Capacity Capacité Kapasite	A	A1	E	H	L	B	N.Max (1/min)	T.Max. (Nm)	Kg	Euro
TORK30E25A070	30	ER25 (2 - 16)	25	84	26	70	59	64	6000	40		
TORK30E25B070	30	ER25 (2 - 16)	25	84	26	70	59	64	6000	40		
TORK40E32A090	40	ER32 (2 - 20)	35	99,5	38	90	68	76	6000	50		
TORK40E32B090	40	ER32 (2 - 20)	35	99,5	38	90	68	76	6000	50		
TORK50E40A112	50	ER40 (3 - 26)	30	126	44	112	84	88	5000	80		
TORK50E40B112	50	ER40 (3 - 26)	30	126	44	112	84	88	5000	80		

	VDI 30	VDI 40	VDI 50
C40	X		
C47	X		
C48	X		
C56	X	X	
C63	X	X	X
C64			X
C70		X	X
C90		X	

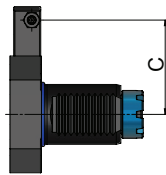

	VDI 30	VDI 40	VDI 50
D35	X		
D42		X	
D48		X	
D50		X	
D55	X		
D56		X	
D63		X	

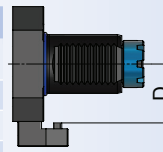

Interne Kühlmittelzufuhr kann als Option bestellt werden.
(Beispiel Bestellnummer: TORK40E32A090C63IK)

Internal coolant supply can be ordered as option.
(Example order number: TORK40E32A090C63IK)

L'alimentation interne en liquide de refroidissement
peut être commandée en option.
(Exemple numéro de commande: TORK40E32A090C63IK)

İsteğe bağlı içten su vermeli sipariş edilebilir.
(Örnek Sipariş Nr.: TORK40E32A090C63IK)

Achtung: Die Lieferung erfolgt mit montage arretierungsklötze! Bitte geben sie C und D masse.

→ (Beispiel Bestellnummer: TORK30E25A070C40 oder TORK30E25A070D35)

Attention: The delivery takes place with assembly lock blocks! Please give C or D dimensions.

→ (Example order code no.: TORK30E25A070C40 oder TORK30E25A070D35)

Attention: La livraison a lieu avec des blocs de verrouillage d'assemblage! Veuillez donner les dimensions C et D.

→ (Exemple commande no.: TORK30E25A070C40 oder TORK30E25A070D35)

Dikkat: Teslimat referans kaması veya dayaması ile gerçekleşir! Lütfen C veya D boyutlarını verin.

→ (Örnek Sipariş Nr.: TORK30E25A070C40 oder TORK30E25A070D35)

Zubehör / Accessories / Accessoires / Yedekler



DIN ISO 15488
Spannzangen System ER
Collets System ER
Pincés de serrage System ER
Pens ER

10.11 - 10.18



DIN ISO 15488
Spannmutter ER
Clamping nuts ER
Écrou de serrage ER
Pens kapağı ER

10.25 - 10.26



Spann Schlüssel ER
Wrench ER
Clé de serrage
Anahtar ER

10.48



AA Schlüssel
AA Wrench
Clé AA
AA Anahtar

10.47



Radial milling head chuck for cutter arbor

Tête de fraiseage radiale porte - fraise

Radial Tahrikli Takım Tutucu Alın Kamalı Malafa

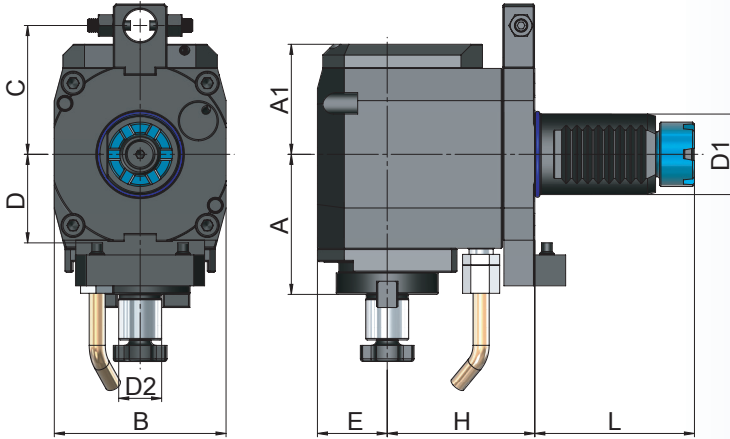
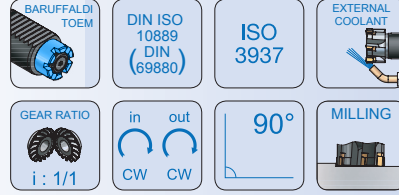

Bestell-Nr.
Order Nr.
Reference
Sipariş Nr.

	D1	D2	A	A1	E	H	L	B	N.Max (1/min)	T.Max. (Nm)	Kg	Euro
TORA30K16A055	30	16	52	41	26	55	59	64	6000	25	3,05	
TORA30K16B055	30	16	52	41	26	55	59	64	6000	25	3,05	
TORA40K16A065	40	16	64	53	38	65	68	76	6000	50		
TORA40K16B065	40	16	64	53	38	65	68	76	6000	50		
TORA40K22A065	40	22	64	53	38	65	68	76	6000	50		
TORA40K22B065	40	22	64	53	38	65	68	76	6000	50		
TORA50K22A075	50	22	71	60	44	75	84	88	5000	80		
TORA50K22B075	50	22	71	60	44	75	84	88	5000	80		
TORA50K27A075	50	27	71	60	44	75	84	88	5000	80		
TORA50K27B075	50	27	71	60	44	75	84	88	5000	80		

	VDI 30	VDI 40	VDI 50
C40	X		
C47	X		
C48	X		
C56	X	X	
C63	X	X	X
C64			X
C70		X	X
C90		X	

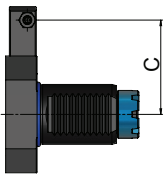

	VDI 30	VDI 40	VDI 50
D35	X		
D42		X	
D48		X	
D50		X	
D55	X		
D56		X	
D63		X	

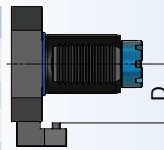

Interne Kühlmittelzufuhr kann als Option bestellt werden.
(Beispiel Bestellnummer: TORA40K16A065C63IK)

Internal coolant supply can be ordered as option.
(Example order number: TORA40K16A065C63IK)

L'alimentation interne en liquide de refroidissement
peut être commandée en option.
(Exemple numéro de commande: TORA40K16A065C63IK)

İsteğe bağlı içten su vermeli sipariş edilebilir.
(Örnek Sipariş Nr.: TORA40K16A065C63IK)

Achtung: Die Lieferung erfolgt mit montage arretierungsklötze! Bitte geben sie C und D masse.

(Beispiel Bestellnummer: TORA30K16A055C40 oder TORA30K16A055D35)

Attention: The delivery takes place with assembly lock blocks! Please give C or D dimensions.

(Example order code no.: TORA30K16A055C40 or TORA30K16A055D35)

Attention: La livraison a lieu avec des blocs de verrouillage d'assemblage! Veuillez donner les dimensions C et D.

(Exemple commande no.: TORA30K16A055C40 ou TORA30K16A055D35)

Dikkat: Teslimat referans kaması veya dayaması ile gerçekleşir! Lütfen C veya D boyutlarını verin.

(Örnek Sipariş Nr.: TORA30K16A055C40 veya TORA30K16A055D35)

Zubehör / Accessories / Accessoires / Yedekler

DIN 6367



10.45

Fräseranzugsschrauben
Drawn in bolt
Vis de serrage
Alın sıkma civatası



10.44

Mitnehmersteine
Drive keys
Entraîneur
Kama

DIN 6368



10.46

Spannschlüssel für Aufsteckdorne
Wrench
Clé de serrage
Alın civatası sıkma anahtarı



Axial drilling - milling head collet chuck

Tetè de percage - fraisage axiale mandrin pour pinces

Axial Tahrikli Takım Tutucu Pens Başlığı

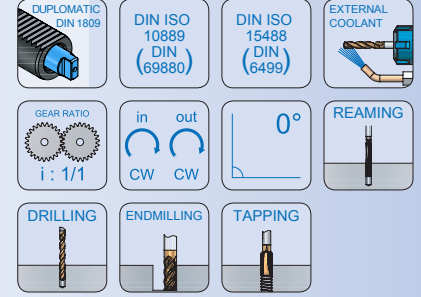
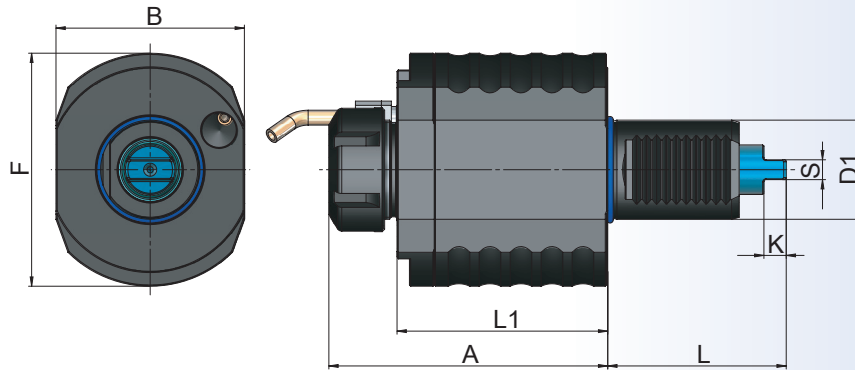

Bestell-Nr. Order Nr. Reference Sipariş Nr.	D1	Spannbereich Capacity Capacité Kapasite	A	L	L1	B	F	K	S	N.Max (1/min)	T.Max. (Nm)	Kg	Euro
09AX25E25066	25	ER25 (2 - 16)	66	72,5	48,5	65	70	7	7,8	6000	25		
09AX30E25090	30	ER25 (2 - 16)	90	59	58	62	70	7	6	6000	25	2,05	
09AX40E32112	40	ER32 (2 - 20)	112,5	72	76	76	94	9	8	6000	50	4,10	
09AX40E40126	40	ER40 (3 - 26)	126,5	72	76	76	94	9	8	6000	50	4,45	
09AX50E32117	50	ER32 (2 - 20)	117,5	92	80	88	102	13	13	5000	80	5,75	
09AX50E40122	50	ER40 (3 - 26)	122	92	80	88	102	13	13	5000	80	5,85	

Zubehör / Accessories / Accessoires / Yedekler

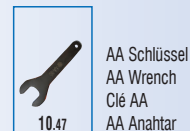



Axial milling head chuck for cutter arbor

Tetê de fraisage axiale porte - fraise

Axial Tahrikli Takım Tutucu Alın Kamalı Malafa

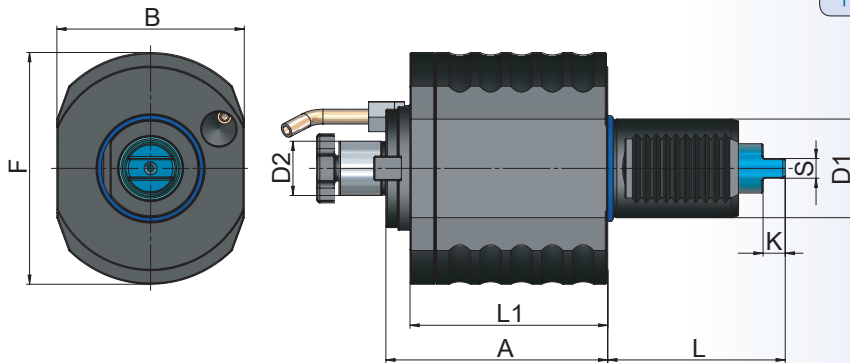

Bestell-Nr. Order Nr. Reference Sipariş Nr.	D1	D2	A	L	L1	B	F	K	S	N.Max (1/min)	T.Max. (Nm)	Kg	Euro
09AX30K16071	30	16	71	62	58	62	70	7	6	6000	25	2,05	
09AX40K16090	40	16	90	72	76	76	94	9	8	6000	50	4,10	
09AX40K22090	40	22	90	72	76	76	94	9	8	6000	50	4,30	
09AX50K22095	50	22	95	92	80	88	102	13	13	5000	80	5,85	
09AX50K27095	50	27	95	92	80	88	102	13	13	5000	80	6,00	

Zubehör / Accessories / Accessoires / Yedekler

DIN 6367



Fräseranzugsschrauben
Drawn in bolt
Vis de serrage
Alın sıkma civatası

10.45

DIN 6368



Mitnehmersteine
Drive keys
Entraîneur
Kama

10.44

DIN 6368



Spannschlüssel für Aufsteckdorne
Wrench
Clé de serrage
Alın civatası sıkma anahtarı

10.46



Radial drilling - milling head collet chuck

Tête de perçage - fraisage radiale mandrin pour pinces

Radial Tahrikli Takım Tutucu Pens Başlığı

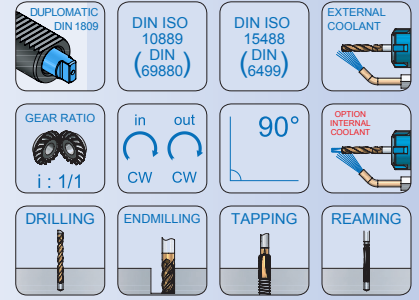
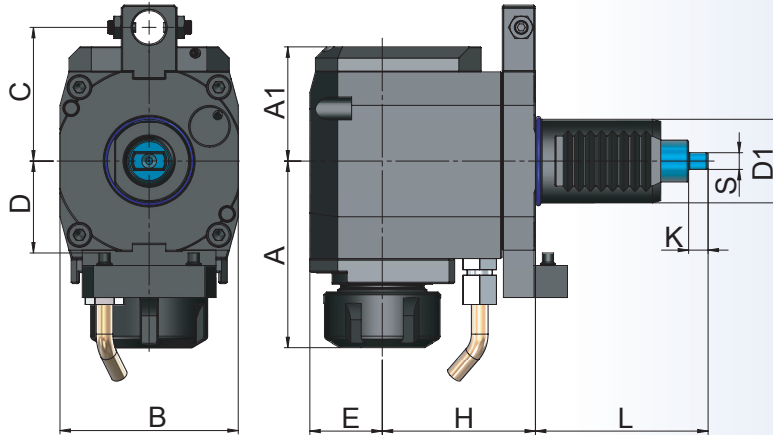

Bestell-Nr. Order Nr. Reference Sipariş Nr.	D1	Spannbereich Capacity Capacité Kapasite	A	A1	E	H	L	B	L	B	N.Max (1/min)	T.Max. (Nm)	Kg	Euro
09RA25E25A075	25	ER25 (2 - 16)	66	41	26	75	72,5	64	7	7,8	6000	25	3,45	
→ 09RA30E25A055	30	ER25 (2 - 16)	67	41	26	55	62	64	7	6	6000	25	2,90	
09RA30E25B055	30	ER25 (2 - 16)	67	41	26	55	62	64	7	6	6000	25	2,90	
09RA40E32A065	40	ER32 (2 - 20)	85	53	38	65	72	76	9	8	6000	50	5,30	
09RA40E32B065	40	ER32 (2 - 20)	85	53	38	65	72	76	9	8	6000	50	5,30	
09RA40E40A065	40	ER40 (3 - 26)	98	53	38	65	72	76	9	8	6000	50	6,00	
09RA40E40B065	40	ER40 (3 - 26)	98	53	38	65	72	76	9	8	6000	50	6,00	
09RA50E32A075	50	ER32 (2 - 20)	92,5	60	44	75	92	88	13	13	5000	80		
09RA50E32B075	50	ER32 (2 - 20)	92,5	60	44	75	92	88	13	13	5000	80		
09RA50E40A075	50	ER40 (3 - 26)	98,5	60	44	75	92	88	13	13	5000	80	8,60	
09RA50E40B075	50	ER40 (3 - 26)	98,5	60	44	75	92	88	13	13	5000	80	8,60	

	VDI 25	VDI 30	VDI 40	VDI 50
→ C40	X	X		
C47		X		
C48		X		
C56		X	X	
C63		X	X	X
C64				X
C70			X	X
C90			X	

	VDI 30	VDI 40	VDI 50
→ D35	X		
D42		X	
D48		X	
D50		X	
D55	X		
D56		X	
D63		X	

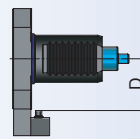

Interne Kühlmittelzufuhr kann als Option bestellt werden.
(Beispiel Bestellnummer: 09RA40E32A065C63IK)

Internal coolant supply can be ordered as option.
(Example order number: 09RA40E32A065C63IK)

L'alimentation interne en liquide de refroidissement peut être commandée en option.
(Exemple numéro de commande: 09RA40E32A065C63IK)

İsteğe bağlı içten su vermeli sipariş edilebilir.
(Örnek Sipariş Nr.: 09RA40E32A065C63IK)

Achtung: Die Lieferung erfolgt mit montage arretierungsklötze! Bitte geben sie C und D masse.
→ (Beispiel Bestellnummer: 09RA30E25A055C40 oder 09RA30E25A055D35)

Attention: The delivery takes place with assembly lock blocks! Please give C or D dimensions.
→ (Example order code no.: 09RA30E25A055C40 oder 09RA30E25A055D35)

Attention: La livraison a lieu avec des blocs de verrouillage d'assemblage! Veuillez donner les dimensions C et D.
→ (Exemple commande no.: 09RA30E25A055C40 oder 09RA30E25A055D35)

Dikkat: Teslimat referans kaması veya dayaması ile gerçekleşir! Lütfen C veya D boyutlarını verin.
→ (Örnek Sipariş Nr.: 09RA30E25A055C40 oder 09RA30E25A055D35)

Zubehör / Accessories / Accessoires / Yedekler



10.11 - 10.18

Spannzangen System ER
Collets System ER
Pincas de serrage System ER
Pens ER



10.25 - 10.26

Spannmutter ER
Clamping nuts ER
Écrou de serrage ER
Pens kapağı ER



10.48

Spann Schlüssel ER
Wrench ER
Clé de serrage
Anahtar ER



10.47

AA Schlüssel
AA Wrench
Clé AA
AA Anahtar



Radial drilling - milling head collet chuck - shifted

Tête de perçage - fraisage radiale mandrin pour pinces - décalé

Radial Tahrikli Takım Tutucu Pens Başlığı - Eksenden Kaçık

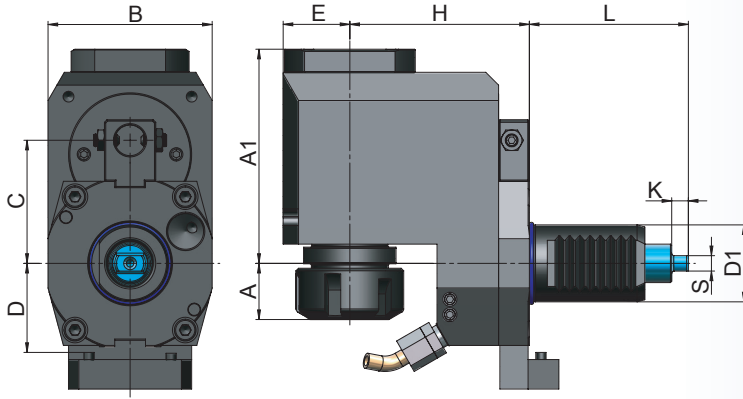
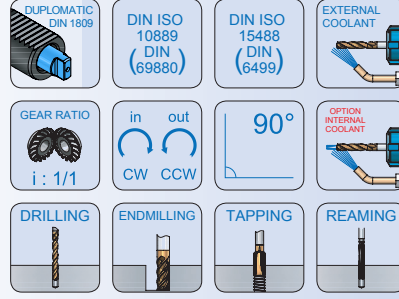

Bestell-Nr. Order Nr. Reference Sipariş Nr.	D1	Spannbereich Capacity Capacité Kapasite	A	A1	E	H	L	B	K	S	N.Max (1/min)	T.Max. (Nm)	Kg	Euro
09RK30E25A070	30	ER25 (2 - 16)	25	84	26	70	62	64	7	6	6000	25		
09RK30E25B070	30	ER25 (2 - 16)	25	84	26	70	62	64	7	6	6000	25		
09RK40E32A090	40	ER32 (2 - 20)	35	99,5	38	90	72	76	9	8	6000	50		
09RK40E32B090	40	ER32 (2 - 20)	35	99,5	38	90	72	76	9	8	6000	50		
09RK50E40A112	50	ER40 (3 - 26)	30	126	45	112	92	88	13	13	5000	80		
09RK50E40B112	50	ER40 (3 - 26)	30	126	45	112	92	88	13	13	5000	80		

	VDI 30	VDI 40	VDI 50
C40	X		
C47	X		
C48	X		
C56	X	X	
C63	X	X	X
C64			X
C70		X	X
C90		X	

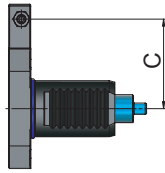

	VDI 30	VDI 40	VDI 50
D35	X		
D42		X	
D48		X	
D50		X	
D55	X		
D56		X	
D63		X	

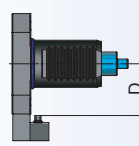

Interne Kühlmittelzufuhr kann als Option bestellt werden.
(Beispiel Bestellnummer: 09RK40E32A090C63IK)

Internal coolant supply can be ordered as option.
(Example order number: 09RK40E32A090C63IK)

L'alimentation interne en liquide de refroidissement
peut être commandée en option.
(Exemple numéro de commande: 09RK40E32A090C63IK)

İsteğe bağlı içten su vermeli sipariş edilebilir.
(Örnek Sipariş Nr.: 09RK40E32A090C63IK)

Achtung: Die Lieferung erfolgt mit montage arretierungsklötze! Bitte geben sie C und D masse.
(Beispiel Bestellnummer: 09RK30E25A070C40 oder 09RK30E25A070D35)

Attention: The delivery takes place with assembly lock blocks! Please give C or D dimensions.
(Example order code no.: 09RK30E25A070C40 or 09RK30E25A070D35)

Attention: La livraison a lieu avec des blocs de verrouillage d'assemblage! Veuillez donner les dimensions C et D.
(Exemple commande no.: 09RK30E25A070C40 ou 09RK30E25A070D35)

Dikkat: Teslimat referans kaması veya dayaması ile gerçekleşir! Lütfen C veya D boyutlarını verin.
(Örnek Sipariş Nr.: 09RK30E25A070C40 veya 09RK30E25A070D35)

Zubehör / Accessories / Accessoires / Yedekler

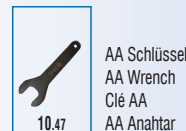



Radial Fräskopf Fräsdornaufnahme

Duplomatic DIN 1809

Radial milling head chuck for cutter arbor

Tetê de fraisage radiale porte - fraise

Radial Tahrikli Takım Tutucu Alın Kamalı Malafa



DIN ISO
10889
DIN
(69880)

ISO
3937



in out
CW CW

90°

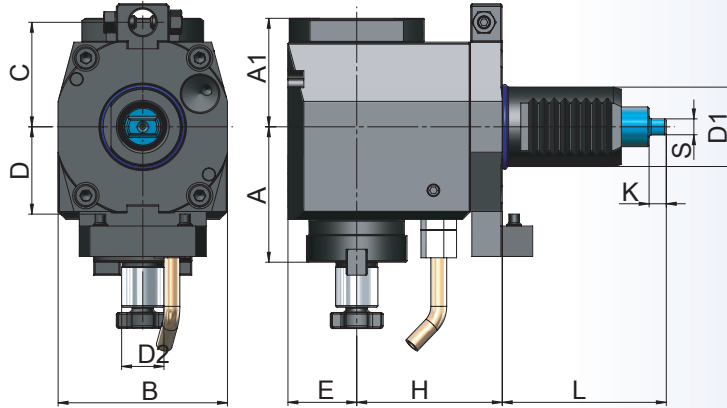

Bestell-Nr.
Order Nr.
Reference
Sipariş Nr.

	D1	D2	A	A1	E	H	L	B	K	S	N.Max (1/min)	T.Max. (Nm)	Kg	Euro
09RA30K16A055	30	16	52	41	26	55	62	64	7	6	6000	25		
09RA30K16B055	30	16	52	41	26	55	62	64	7	6	6000	25		
09RA40K16A065	40	16	64	53	38	65	72	76	9	8	6000	50		
09RA40K16B065	40	16	64	53	38	65	72	76	9	8	6000	50		
09RA40K22A065	40	22	64	53	38	65	72	76	9	8	6000	50		
09RA40K22B065	40	22	64	53	38	65	72	76	9	8	6000	50		
09RA50K22A075	50	22	71	60	44	75	92	88	13	13	5000	80	8,80	
09RA50K22B075	50	22	71	60	44	75	92	88	13	13	5000	80	8,80	
09RA50K27A075	50	27	71	60	44	75	92	88	13	13	5000	80		
09RA50K27B075	50	27	71	60	44	75	92	88	13	13	5000	80		

	VDI 30	VDI 40	VDI 50
C40	X		
C47	X		
C48	X		
C56	X	X	
C63	X	X	X
C64			X
C70		X	X
C90		X	

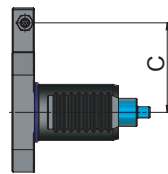

	VDI 30	VDI 40	VDI 50
D35	X		
D42		X	
D48		X	
D50		X	
D55	X		
D56		X	
D63		X	

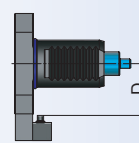

Interne Kühlmittelzufuhr kann als Option bestellt werden.
(Beispiel Bestellnummer: 09RA40K16A065C63IK)

Internal coolant supply can be ordered as option.
(Example order number: 09RA40K16A065C63IK)

L'alimentation interne en liquide de refroidissement
peut être commandée en option.
(Exemple numéro de commande: 09RA40K16A065C63IK)

İsteğe bağlı içten su vermeli sipariş edilebilir.
(Örnek Sipariş Nr.: 09RA40K16A065C63IK)

Achtung: Die Lieferung erfolgt mit montage arretierungsklötze! Bitte geben sie C und D masse.

→ (Beispiel Bestellnummer: 09RA30K16A055C40 oder 09RA30K16A055D35)

Attention: The delivery takes place with assembly lock blocks! Please give C or D dimensions.

→ (Example order code no.: 09RA30K16A055C40 oder 09RA30K16A055D35)

Attention: La livraison a lieu avec des blocs de verrouillage d'assemblage! Veuillez donner les dimensions C et D.

→ (Exemple commande no.: 09RA30K16A055C40 oder 09RA30K16A055D35)

Dikkat: Teslimat referans kaması veya dayaması ile gerçekleşir! Lütfen C veya D boyutlarını verin.

→ (Örnek Sipariş Nr.: 09RA30K16A055C40 oder 09RA30K16A055D35)

Zubehör / Accessories / Accessoires / Yedekler

DIN 6367



10.45

Fräseranzugsschrauben
Drawn in bolt
Vis de serrage
Alın sıkması civatası



10.44

Mitnehmersteine
Drive keys
Entraîneur
Kama

DIN 6368



10.46

Spannschlüssel für Aufsteckdorne
Wrench
Clé de serrage
Alın civatası sıkma anahtar



Axial drilling - milling head collet chuck

Tête de perçage - fraiseage axiale mandrin pour pinces

Axial Tahrikli Takım Tutucu Pens Başlığı

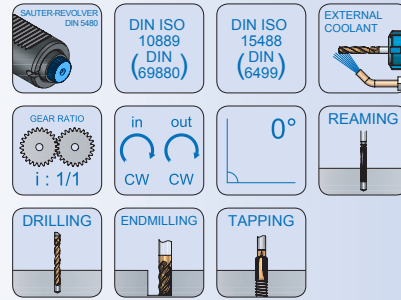
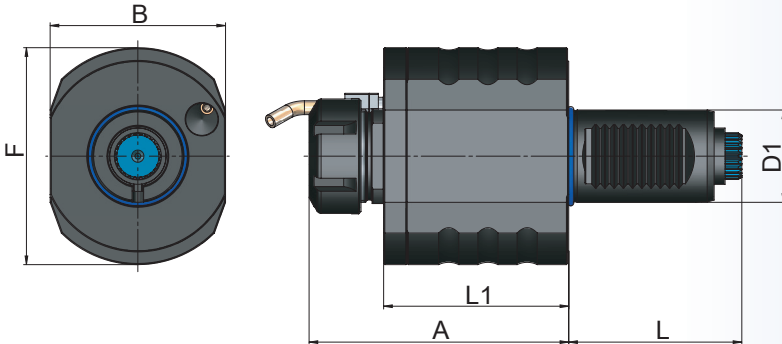

Bestell-Nr. Order Nr. Reference Sipariş Nr.	D1	Spannbereich Capacity Capacité Kapasite	A	L	L1	B	F	N.Max (1/min)	T.Max. (Nm)	Kg	Euro
80AX25E25066	25	ER25 (2 - 16)	84	57	52,5	65	64,5	6000	25		
80AX30E25090	30	ER25 (2 - 16)	90	67	58	62	70	6000	25	2,05	
80AX40E32112	40	ER32 (2 - 20)	112,5	75	76	76	94	6000	50	4,10	
80AX40E40126	40	ER40 (3 - 26)	126,5	75	76	76	94	6000	50	4,45	
80AX50E32117	50	ER32 (2 - 20)	117,5	93	80	88	102	5000	80	5,75	
80AX50E40122	50	ER40 (3 - 26)	122	93	80	88	102	5000	80	5,85	

Zubehör / Accessories / Accessoires / Yedekler

DIN ISO 15488

 Spannzangen System ER
 Collets System ER
 Pincés de serrage System ER
 Pens ER
 10.11 - 10.18

DIN ISO 15488

 Spannmutter ER
 Clamping nuts ER
 Écrou de serrage ER
 Pens kapağı ER
 10.25 - 10.26

 Spanschlüssel ER
 Wrench ER
 Clé de serrage
 Anahtar ER
 10.48



 AA Schlüssel
 AA Wrench
 Clé AA
 AA Anahtar
 10.47



Axial milling head chuck for cutter arbor

Tetê de fraisage axiale porte - fraise

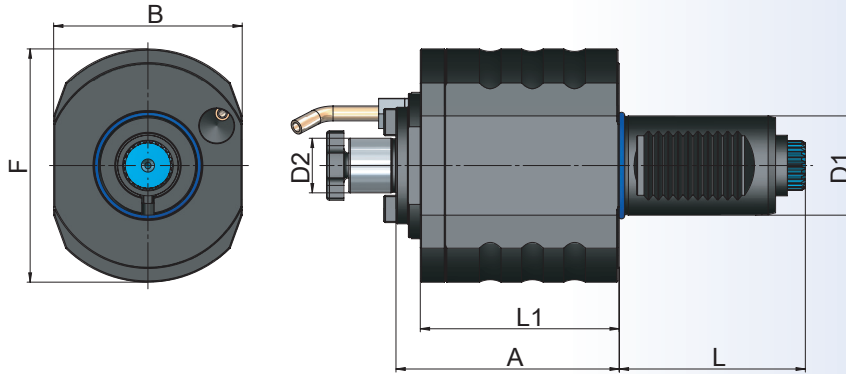
Axial Tahrikli Takım Tutucu Alın Kamalı Malafa



Bestell-Nr. Order Nr. Reference Sipariş Nr.	D1	D2	A	L	L1	B	F	N.Max (1/min)	T.Max. (Nm)	Kg	Euro
80AX30K16071	30	16	71	67	58	62	70	6000	25	2,05	
80AX40K16090	40	16	90	75	76	76	94	6000	50	4,00	
80AX40K22090	40	22	90	75	76	76	94	6000	50	4,30	
80AX50K22095	50	22	95	93	80	88	102	5000	80	5,85	
80AX50K27095	50	27	95	93	80	88	102	5000	80	6,00	

Zubehör / Accessories / Accessoires / Yedekler

DIN 6367



Fräseranzugsschrauben
Drawn in bolt
Vis de serrage
Alın sıkma civatası

10.45



Mitnehmersteine
Drive keys
Entraîneur
Kama

10.44

DIN 6368



Spannschlüssel für Aufsteckdorne
Wrench
Clé de serrage
Alın civatası sıkma anahtar

10.46



Radial drilling - milling head collet chuck

Tête de perçage - fraisage radiale mandrin pour pinces

Radial Tahrikli Takım Tutucu Pens Başlığı

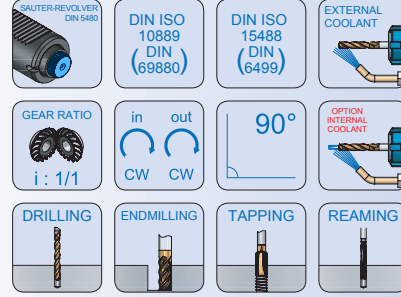
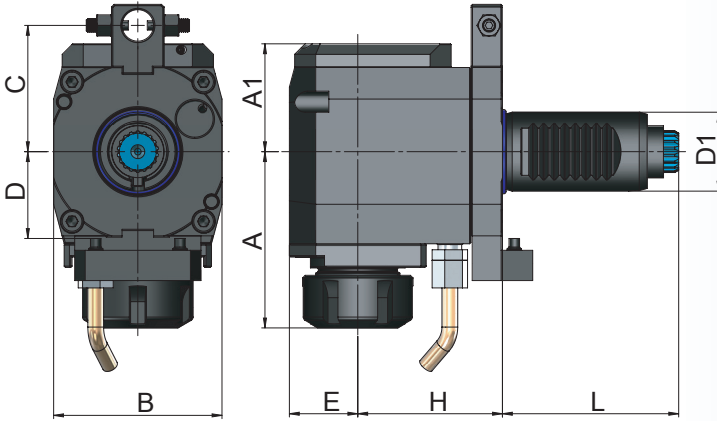

Bestell-Nr. Order Nr. Reference Sipariş Nr.	D1	Spannbereich Capacity Capacité Kapasite	A	A1	E	H	L	B	N.Max (1/min)	T.Max. (Nm)	Kg	Euro
80RA25E25A075	25	ER25 (2 - 16)	84	41	26	75	57	64	6000	25	3,15	
80RA25E25B075	25	ER25 (2 - 16)	84	41	26	75	57	64	6000	25	3,15	
80RA30E25A055	30	ER25 (2 - 16)	67	41	26	55	67	64	6000	25	2,95	
80RA30E25B055	30	ER25 (2 - 16)	67	41	26	55	67	64	6000	25	2,95	
80RA40E32A065	40	ER32 (2 - 20)	85	53	38	65	75	76	6000	50	5,40	
80RA40E32B065	40	ER32 (2 - 20)	85	53	38	65	75	76	6000	50	5,40	
80RA40E40A065	40	ER40 (3 - 26)	98	53	38	65	75	76	6000	50	6,00	
80RA40E40B065	40	ER40 (3 - 26)	98	53	38	65	75	76	6000	50	6,00	
80RA50E32A075	50	ER32 (2 - 20)	92,5	60	44	75	93	88	5000	80	8,95	
80RA50E32B075	50	ER32 (2 - 20)	92,5	60	44	75	93	88	5000	80	8,95	
80RA50E40A075	50	ER40 (3 - 26)	98,5	60	44	75	93	88	5000	80	9,05	
80RA50E40B075	50	ER40 (3 - 26)	98,5	60	44	75	93	88	5000	80	9,05	

	VDI 25	VDI 30	VDI 40	VDI 50
C40	X	X		
C47		X		
C48		X		
C56		X	X	
C63		X	X	X
C64				X
C70			X	X
C90			X	

	VDI 30	VDI 40	VDI 50
D35	X		
D42		X	
D48		X	
D50		X	
D55	X		
D56		X	
D63		X	

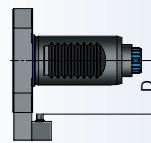

Interne Kühlmittelzufuhr kann als Option bestellt werden.
(Beispiel Bestellnummer: 80RA40E32A065C63IK)

Internal coolant supply can be ordered as option.
(Example order number: 80RA40E32A065C63IK)

L'alimentation interne en liquide de refroidissement peut être commandée en option.
(Exemple numéro de commande: 80RA40E32A065C63IK)

İsteğe bağlı içten su vermeli sipariş edilebilir.
(Örnek Sipariş Nr.: 80RA40E32A065C63IK)

Achtung: Die Lieferung erfolgt mit montage arretierungsklötze! Bitte geben sie C und D masse.
(Beispiel Bestellnummer: 80RA30E25A055C40 oder 80RA30E25A055D35)

Attention: The delivery takes place with assembly lock blocks! Please give C or D dimensions.
(Example order code no.: 80RA30E25A055C40 oder 80RA30E25A055D35)

Attention: La livraison a lieu avec des blocs de verrouillage d'assemblage! Veuillez donner les dimensions C et D.
(Exemple commande no.: 80RA30E25A055C40 oder 80RA30E25A055D35)

Dikkat: Teslimat referans kaması veya dayaması ile gerçekleşir! Lütfen C veya D boyutlarını verin.
(Örnek Sipariş Nr.: 80RA30E25A055C40 oder 80RA30E25A055D35)

Zubehör / Accessories / Accessoires / Yedekler

DIN ISO 15488
Spannzangen System ER
Collets System ER
Pincas de serrage System ER
Pens ER
10.11 - 10.18

DIN ISO 15488
Spannmutter ER
Clamping nuts ER
Écrou de serrage ER
Pens kapağı ER
10.25 - 10.26

Spannschlüssel ER
Wrench ER
Clé de serrage
Anahtar ER
10.48

AA Schlüssel
AA Wrench
Clé AA
AA Anahtar
10.47



Radial drilling - milling head collet chuck - shifted

Tête de perçage - fraisage radiale mandrin pour pinces - décalé

Radial Tahrikli Takım Tutucu Pens Başlığı - Eksenden Kaçığı

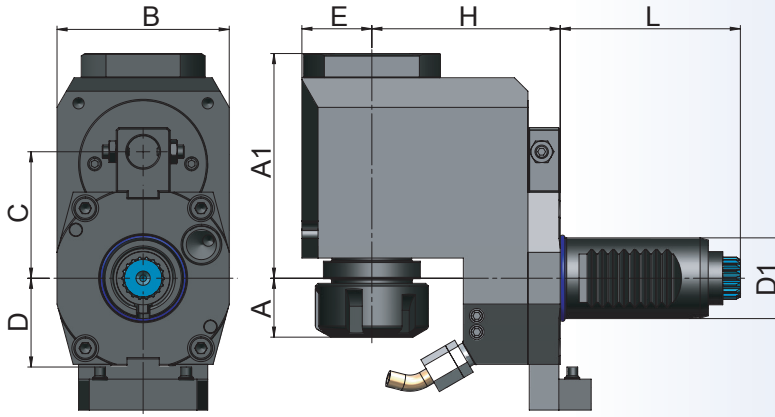

Bestell-Nr. Order Nr. Reference Sipariş Nr.	D1	Spannbereich Capacity Capacité Kapasite	A	A1	E	H	L	B	N.Max (1/min)	T.Max. (Nm)	Kg	Euro
80RK30E25A070	30	ER25 (2 - 16)	25	84	26	70	67	64	6000	40	3,75	
80RK30E25B070	30	ER25 (2 - 16)	25	84	26	70	67	64	6000	40	3,75	
80RK40E32A090	40	ER32 (2 - 20)	35	99,5	38	90	75	76	6000	50	6,80	
80RK40E32B090	40	ER32 (2 - 20)	35	99,5	38	90	75	76	6000	50	6,80	
80RK50E40A112	50	ER40 (3 - 26)	30	126	44	112	93	88	5000	80	12,50	
80RK50E40B112	50	ER40 (3 - 26)	30	126	44	112	93	88	5000	80	12,50	

	VDI 30	VDI 40	VDI 50
C40	X		
C47	X		
C48	X		
C56	X	X	
C63	X	X	X
C64			X
C70		X	X
C90		X	

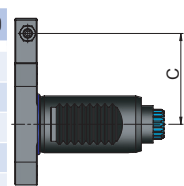

	VDI 30	VDI 40	VDI 50
D35	X		
D42		X	
D48		X	
D50		X	
D55	X		
D56		X	
D63		X	

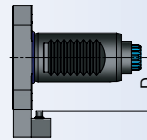

Interne Kühlmittelzufuhr kann als Option bestellt werden.
(Beispiel Bestellnummer: 80RK40E32A090C63IK)

Internal coolant supply can be ordered as option.
(Example order number: 80RK40E32A090C63IK)

L'alimentation interne en liquide de refroidissement
peut être commandée en option.
(Exemple numéro de commande: 80RK40E32A090C63IK)

İsteğe bağlı içten su vermeli sipariş edilebilir.
(Örnek Sipariş Nr.: 80RK40E32A090C63IK)

Achtung: Die Lieferung erfolgt mit montage arretierungsklötze! Bitte geben sie C und D masse.

(Beispiel Bestellnummer: 80RK30E25A070C40 oder 80RK30E25A070D35)

Attention: The delivery takes place with assembly lock blocks! Please give C or D dimensions.

(Example order code no.: 80RK30E25A070C40 oder 80RK30E25A070D35)

Attention: La livraison a lieu avec des blocs de verrouillage d'assemblage! Veuillez donner les dimensions C et D.

(Exemple commande no.: 80RK30E25A070C40 oder 80RK30E25A070D35)

Dikkat: Teslimat referans kaması veya dayaması ile gerçekleşir! Lütfen C veya D boyutlarını verin.

(Örnek Sipariş Nr.: 80RK30E25A070C40 oder 80RK30E25A070D35)

Zubehör / Accessories / Accessoires / Yedekler



Spannzangen System ER
Collets System ER
Pincés de serrage System ER
Pens ER



Spannmutter ER
Clamping nuts ER
Écrou de serrage ER
Pens kapağı ER



Spann Schlüssel ER
Wrench ER
Clé de serrage
Anahtar ER



AA Schlüssel
AA Wrench
Clé AA
AA Anahtar



Radial milling head chuck for cutter arbor

Tête de fraisage radiale porte - fraise

Radial Tahrikli Takım Tutucu Alın Kamalı Malafa

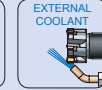
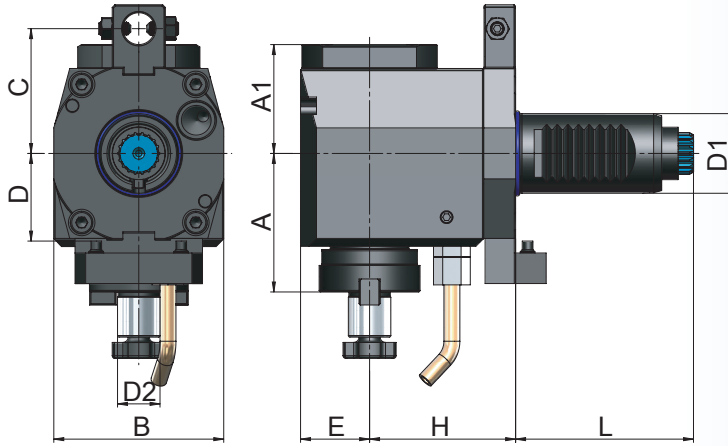

Bestell-Nr. Order Nr. Reference Sipariş Nr.	D1	D2	A	A1	E	H	L	B	N.Max (1/min)	T.Max. (Nm)	Kg	Euro
80RA30K16A055	30	16	52	41	26	55	67	64	6000	25		
80RA30K16B055	30	16	52	41	26	55	67	64	6000	25		
80RA40K16A065	40	16	64	53	38	65	75	76	6000	50		
80RA40K16B065	40	16	64	53	38	65	75	76	6000	50		
80RA40K22A065	40	22	64	53	38	65	75	76	6000	50		
80RA40K22B065	40	22	64	53	38	65	75	76	6000	50		
80RA50K22A075	50	22	71	60	44	75	93	88	5000	80		
80RA50K22B075	50	22	71	60	44	75	93	88	5000	80		
80RA50K27A075	50	27	71	60	44	75	93	88	5000	80		
80RA50K27B075	50	27	71	60	44	75	93	88	5000	80		

	VDI 30	VDI 40	VDI 50
C40	X		
C47	X		
C48	X		
C56	X	X	
C63	X	X	X
C64			X
C70		X	X
C90		X	

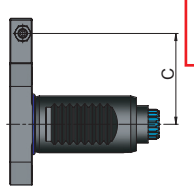

	VDI 30	VDI 40	VDI 50
D35	X		
D42		X	
D48		X	
D50		X	
D55	X		
D56		X	
D63		X	

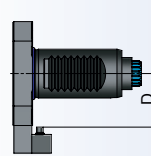

Interne Kühlmittelzufuhr kann als Option bestellt werden.
(Beispiel Bestellnummer: 80RA40K16A065C63IK)

Internal coolant supply can be ordered as option.
(Example order number: 80RA40K16A065C63IK)

L'alimentation interne en liquide de refroidissement
peut être commandée en option.
(Exemple numéro de commande: 80RA40K16A065C63IK)

İsteğe bağlı içten su vermeli sipariş edilebilir.
(Örnek Sipariş Nr: 80RA40K16A065C63IK)

Achtung: Die Lieferung erfolgt mit montage arretierungsklötze! Bitte geben sie C und D masse.
(Beispiel Bestellnummer: 80RA30K16A055C40 oder 80RA30K16A055D35)

Attention: The delivery takes place with assembly lock blocks! Please give C or D dimensions.
(Example order code no.: 80RA30K16A055C40 or 80RA30K16A055D35)

Attention: La livraison a lieu avec des blocs de verrouillage d'assemblage! Veuillez donner les dimensions C et D.
(Exemple commande no.: 80RA30K16A055C40 ou 80RA30K16A055D35)

Dikkat: Teslimat referans kaması veya dayaması ile gerçekleşir! Lütfen C veya D boyutlarını verin.
(Örnek Sipariş Nr.: 80RA30K16A055C40 veya 80RA30K16A055D35)

Zubehör / Accessories / Accessoires / Yedekler

DIN 6367



Fräseranzugsschrauben
Drawn in bolt
Vis de serrage
Alın sıkma civatası

10.45

DIN 6368



Mitnehmersteine
Drive keys
Entraîneur
Kama

10.44

DIN 6367



Spannschlüssel für Aufsteckdorne
Wrench
Clé de serrage
Alın civatası sıkma anahtarı

10.46



Axial drilling - milling head collet chuck

Tetê de percage - fraisage axiale mandrin pour pinces

Axial Tahrikli Takım Tutucu Pens Başlığı

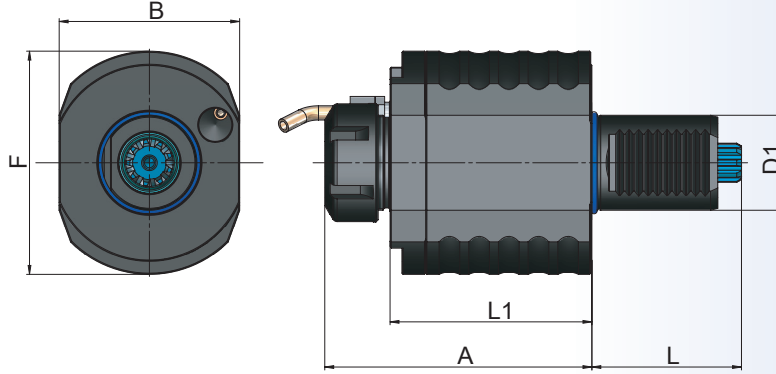

Bestell-Nr. Order Nr. Reference Sipariş Nr.	D1	Spannbereich Capacity Capacité Kapasite	A	L	L1	B	F	N.Max (1/min)	T.Max. (Nm)	Kg	Euro
82AX30E25090	30	ER25 (2 - 16)	90	55	58	62	70	6000	25	1,85	
82AX40E32112	40	ER32 (2 - 20)	112,5	63	76	76	94	6000	50	4,05	
82AX40E40126	40	ER40 (3 - 26)	126,5	63	76	76	94	6000	50	4,30	
82AX50E32117	50	ER32 (2 - 20)	117,5	93	80	88	102	5000	80	5,75	
82AX50E40122	50	ER40 (3 - 26)	122	93	80	88	102	5000	80	5,95	

Zubehör / Accessories / Accessoires / Yedekler



Spannzangen System ER
Collets System ER
Pincés de serrage System ER
Pens ER



Spannmutter ER
Clamping nuts ER
Écrou de serrage ER
Pens kapağı ER



Spannschlüssel ER
Wrench ER
Clé de serrage
Anahtar ER



AA Schlüssel
AA Wrench
Clé AA
AA Anahtar



Axial milling head chuck for cutter arbor

Tetê de fraisage axiale porte - fraise

Axial Tahrıklı Takım Tutucu Alın Kamalı Malafa

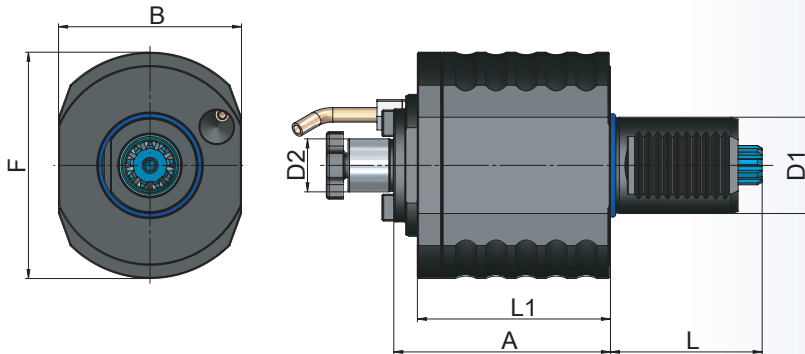

Bestell-Nr. Order Nr. Reference Sipariş Nr.	D1	D2	A	L	L1	B	F	N.Max (1/min)	T.Max. (Nm)	Kg	Euro
82AX30K16071	30	16	71	55	58	62	70	6000	25	1,85	
82AX40K16090	40	16	90	63	76	76	94	6000	50	4,05	
82AX40K22090	40	22	90	63	76	76	94	6000	50	4,15	
82AX50K22095	50	22	95	93	80	88	102	5000	80	5,85	
82AX50K27095	50	27	95	93	80	88	102	5000	80	6,00	

Zubehör / Accessories / Accessoires / Yedekler

DIN 6367



Fräseranzugsschrauben
Drawn in bolt
Vis de serrage
Alın sıkma civatası

10.45



Mitnehmersteine
Drive keys
Entraîneur
Kama

10.44

DIN 6368



Spannschlüssel für Aufsteckdorne
Wrench
Clé de serrage
Alın civatası sıkma anahtarı

10.46



Radial drilling - milling head collet chuck

Tête de perçage - fraisage radiale mandrin pour pinces

Radial Tahrikli Takım Tutucu Pens Başlığı

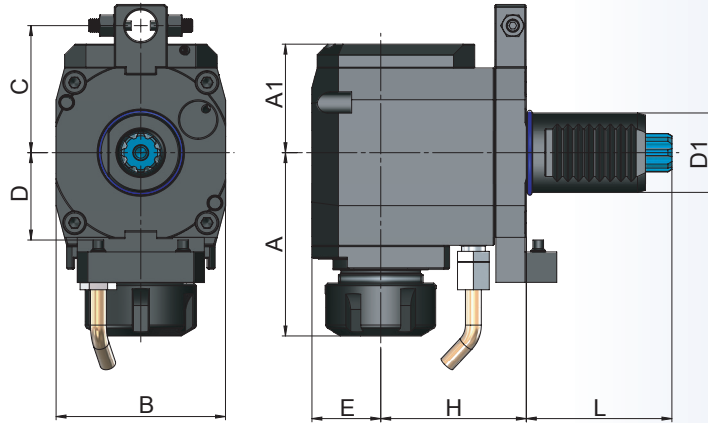

Bestell-Nr. Order Nr. Reference Sipariş Nr.	D1	Spannbereich Capacity Capacité Kapasite	A	A1	E	H	L	B	N.Max (1/min)	T.Max. (Nm)	Kg	Euro
82RA30E25A055	30	ER25 (2 - 16)	67	41	26	55	55	64	6000	25	2,85	
82RA30E25B055	30	ER25 (2 - 16)	67	41	26	55	55	64	6000	25	2,85	
82RA40E32A065	40	ER32 (2 - 20)	85	53	38	65	63	76	6000	50	5,50	
82RA40E32B065	40	ER32 (2 - 20)	85	53	38	65	63	76	6000	50	5,50	
82RA40E40A065	40	ER40 (3 - 26)	98	53	38	65	63	76	6000	50	5,90	
82RA40E40B065	40	ER40 (3 - 26)	98	53	38	65	63	76	6000	50	5,90	
82RA50E32A075	50	ER32 (2 - 20)	92,5	60	44	75	93	88	5000	80	8,80	
82RA50E32B075	50	ER32 (2 - 20)	92,5	60	44	75	93	88	5000	80	8,80	
82RA50E40A075	50	ER40 (3 - 26)	98,5	60	44	75	93	88	5000	80		
82RA50E40B075	50	ER40 (3 - 26)	98,5	60	44	75	93	88	5000	80		

	VDI 30	VDI 40	VDI 50
C40	X		
C47	X		
C48	X		
C56	X	X	
C63	X	X	X
C64			X
C70		X	X
C90		X	

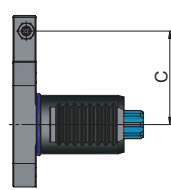

	VDI 30	VDI 40	VDI 50
D35	X		
D42		X	
D48		X	
D50		X	
D55	X		
D56		X	
D63		X	

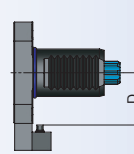

Interne Kühlmittelzufuhr kann als Option bestellt werden.
(Beispiel Bestellnummer: 82RA40E32A065C63IK)

Internal coolant supply can be ordered as option.
(Example order number: 82RA40E32A065C63IK)

L'alimentation interne en liquide de refroidissement
peut être commandée en option.
(Exemple numéro de commande: 82RA40E32A065C63IK)

İsteğe bağlı içten su vermeli sipariş edilebilir.
(Örnek Sipariş Nr.: 82RA40E32A065C63IK)

Achtung: Die Lieferung erfolgt mit montage arretierungsklötze! Bitte geben sie C und D masse.

→ (Beispiel Bestellnummer: 82RA30E25A055C40 oder 82RA30E25A055D35)

Attention: The delivery takes place with assembly lock blocks! Please give C or D dimensions.

→ (Example order code no.: 82RA30E25A055C40 oder 82RA30E25A055D35)

Attention: La livraison a lieu avec des blocs de verrouillage d'assemblage! Veuillez donner les dimensions C et D.

→ (Exemple commande no.: 82RA30E25A055C40 oder 82RA30E25A055D35)

Dikkat: Teslimat referans kaması veya dayaması ile gerçekleşir! Lütfen C veya D boyutlarını verin.

→ (Örnek Sipariş Nr.: 82RA30E25A055C40 oder 82RA30E25A055D35)

Zubehör / Accessories / Accessoires / Yedekler



Spannzangen System ER
Collets System ER
Pincas de serrage System ER
Pens ER



Spannmutter ER
Clamping nuts ER
Écrou de serrage ER
Pens kapağı ER



Spann Schlüssel ER
Wrench ER
Clé de serrage
Anahtar ER



AA Schlüssel
AA Wrench
Clé AA
AA Anahtar



Radial drilling - milling head collet chuck - shifted

Tetê de perçage - fraisage radiale mandrin pour pinces - décalé

Radial Tahrikli Takım Tutucu Pens Başlığı - Eksenden Kaçık

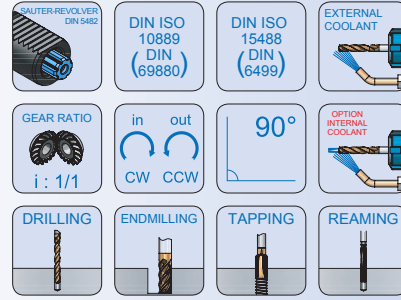
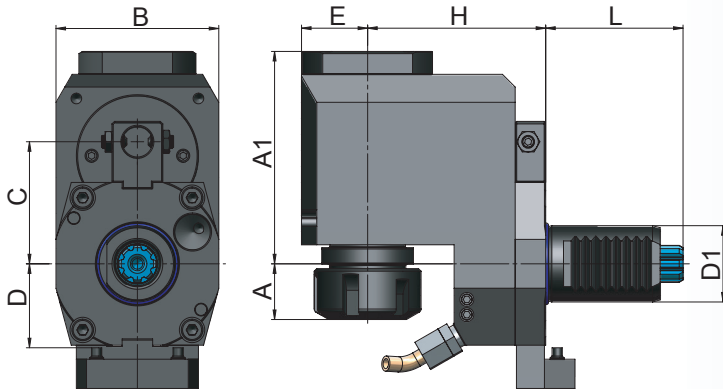

Bestell-Nr. Order Nr. Reference Sipariş Nr.	D1	Spannbereich Capacity Capacité Kapasite	A	A1	E	H	L	B	N.Max (1/min)	T.Max. (Nm)	Kg	Euro
82RK30E25A070	30	ER25 (2 - 16)	25	84	26	70	55	64	6000	40		
82RK30E25B070	30	ER25 (2 - 16)	25	84	26	70	55	64	6000	40		
82RK40E32A090	40	ER32 (2 - 20)	35	99,5	38	90	63	76	6000	50		
82RK40E32B090	40	ER32 (2 - 20)	35	99,5	38	90	63	76	6000	50		
82RK50E40A112	50	ER40 (3 - 26)	30	126	44	112	93	88	5000	80		
82RK50E40B112	50	ER40 (3 - 26)	30	126	44	112	93	88	5000	80		

	VDI 30	VDI 40	VDI 50
C40	X		
C47	X		
C48	X		
C56	X	X	
C63	X	X	X
C64			X
C70		X	X
C90		X	

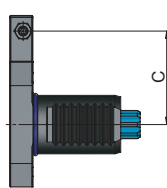

	VDI 30	VDI 40	VDI 50
D35	X		
D42		X	
D48		X	
D50		X	
D55	X		
D56		X	
D63		X	

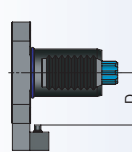

Interne Kühlmittelzufuhr kann als Option bestellt werden.
(Beispiel Bestellnummer: 82RK40E32A090C63IK)

Internal coolant supply can be ordered as option.
(Example order number: 82RK40E32A090C63IK)

L'alimentation interne en liquide de refroidissement
peut être commandée en option.
(Exemple numéro de commande: 82RK40E32A090C63IK)

İsteğe bağlı içten su vermeli sipariş edilebilir.
(Örnek Sipariş Nr.: 82RK40E32A090C63IK)

Achtung: Die Lieferung erfolgt mit montage arretierungsklötze! Bitte geben sie C und D masse.
(Beispiel Bestellnummer: 82RK30E25A070C40 oder 82RK30E25A070D35)

Attention: The delivery takes place with assembly lock blocks! Please give C or D dimensions.
(Example order code no.: 82RK30E25A070C40 or 82RK30E25A070D35)

Attention: La livraison a lieu avec des blocs de verrouillage d'assemblage! Veuillez donner les dimensions C et D.
(Exemple commande no.: 82RK30E25A070C40 ou 82RK30E25A070D35)

Dikkat: Teslimat referans kaması veya dayaması ile gerçekleşir! Lütfen C veya D boyutlarını verin.
(Örnek Sipariş Nr.: 82RK30E25A070C40 veya 82RK30E25A070D35)

Zubehör / Accessories / Accessoires / Yedekler

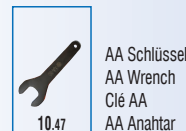
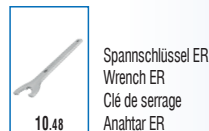



Radial Fräskopf Fräsdornaufnahme

Sauter - Revolver DIN 5482

Radial milling head chuck for cutter arbor

Tetè de fraisage radiale porte - fraise

Radial Tahrikli Takım Tutucu Alın Kamalı Malafa

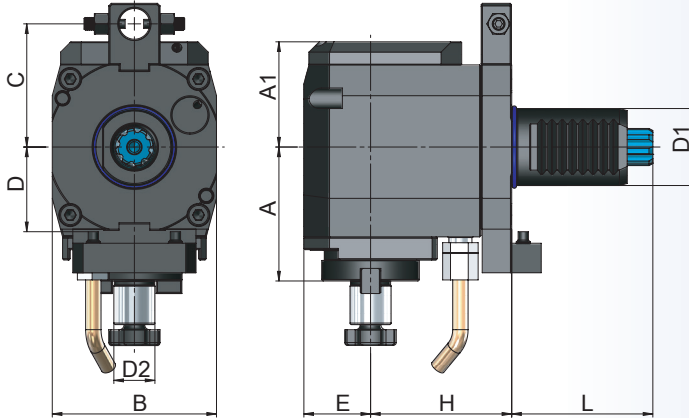

Bestell-Nr. Order Nr. Reference Sipariş Nr.	D1	D2	A	A1	E	H	L	B	N.Max (1/min)	T.Max. (Nm)	Kg	Euro
82RA30K16A055	30	16	52	41	26	55	55	64	6000	25		
82RA30K16B055	30	16	52	41	26	55	55	64	6000	25		
82RA40K16A065	40	16	64	53	38	65	63	76	6000	50		
82RA40K16B065	40	16	64	53	38	65	63	76	6000	50		
82RA40K22A065	40	22	64	53	38	65	63	76	6000	50		
82RA40K22B065	40	22	64	53	38	65	63	76	6000	50		
82RA50K22A075	50	22	71	60	44	75	93	88	5000	80		
82RA50K22B075	50	22	71	60	44	75	93	88	5000	80		
82RA50K27A075	50	27	71	60	44	75	93	88	5000	80		
82RA50K27B075	50	27	71	60	44	75	93	88	5000	80		

	VDI 30	VDI 40	VDI 50
C40	X		
C47	X		
C48	X		
C56	X	X	
C63	X	X	X
C64			X
C70		X	X
C90		X	

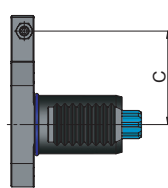

	VDI 30	VDI 40	VDI 50
D35	X		
D42		X	
D48		X	
D50		X	
D55	X		
D56		X	
D63		X	

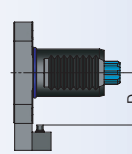

Interne Kühlmittelzufuhr kann als Option bestellt werden.
(Beispiel Bestellnummer: 82RA40K16A065C63IK)

Internal coolant supply can be ordered as option.
(Example order number: 82RA40K16A065C63IK)

L'alimentation interne en liquide de refroidissement peut être commandée en option.
(Exemple numéro de commande: 82RA40K16A065C63IK)

İsteğe bağlı içten su vermeli sipariş edilebilir.
(Örnek Sipariş Nr.: 82RA40K16A065C63IK)

Achtung: Die Lieferung erfolgt mit montage arretierungsklötze! Bitte geben sie C und D masse.

→ (Beispiel Bestellnummer: 82RA30K16A055C40 oder 82RA30K16A055D35)

Attention: The delivery takes place with assembly lock blocks! Please give C or D dimensions.

→ (Example order code no.: 82RA30K16A055C40 oder 82RA30K16A055D35)

Attention: La livraison a lieu avec des blocs de verrouillage d'assemblage! Veuillez donner les dimensions C et D.

→ (Exemple commande no.: 82RA30K16A055C40 oder 82RA30K16A055D35)

Dikkat: Teslimat referans kaması veya dayaması ile gerçekleşir! Lütfen C veya D boyutlarını verin.

→ (Örnek Sipariş Nr.: 82RA30K16A055C40 oder 82RA30K16A055D35)

Zubehör / Accessories / Accessoires / Yedekler

DIN 6367



10.45

Fräseranzugsschrauben
Drive keys
Vis de serrage
Alın sıkması civatası

DIN 6368



10.44

Mitnehmersteine
Drive keys
Entraîneur
Kama

DIN 6368



10.46

Spannschlüssel für Aufsteckdorne
Wrench
Clé de serrage
Alın civatası sıkma anahtar

Axial Bohr - und Fräskopf Spannzangenaufnahme

Mori Seiki BMT32



Axial drilling - milling head collet chuck

Tête de perçage - fraisage axiale mandrin pour pinces

Axial Tahrikli Takım Tutucu Pens Başlığı

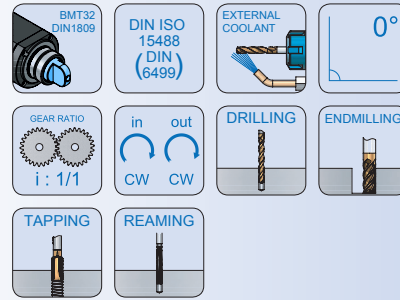
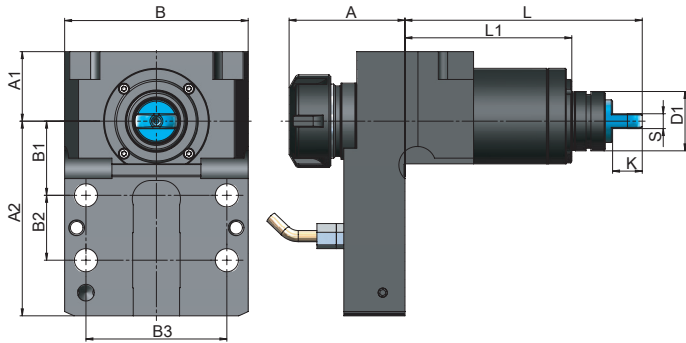

SL 150 / 200 / 250
 ZT 2500 FBT
 Goodway GS 200 / 260 / 280 M-ML-LMS
 CMZ TC 15 / 20 / 25 / 30 / 35
 CMZ TL 20 / 25

Bestell-Nr. Order Nr. Reference Sipariş Nr.	D1	Spannbereich Capacity Capacité Kapasite	A	A1	A2	L	L1	B	B1	B2	B3	K	S	N.Max (1/min)	T.Max. (Nm)	Kg	Euro
GW1AX32E32060	32	ER32 (2 - 20)	60	37,5	105	127	90	99	40	35	76	16	8	6000	50		

Radial Bohr - und Fräskopf Spannzangenaufnahme

Mori Seiki BMT32

Radial drilling - milling head collet chuck

Tête de perçage - fraisage radiale mandrin pour pinces

Radial Tahrikli Takım Tutucu Pens Başlığı

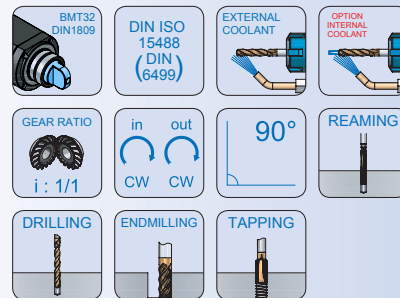
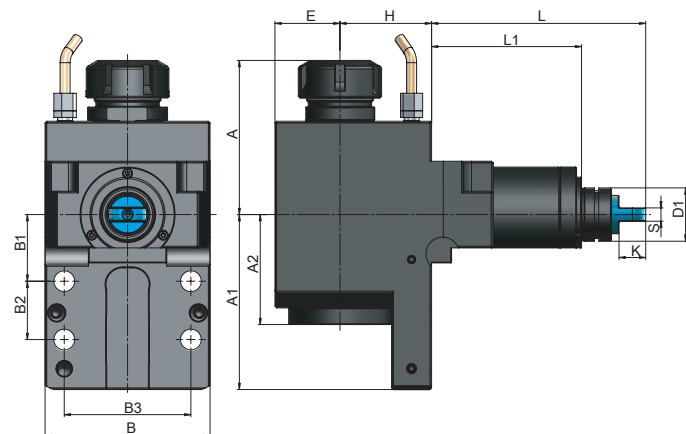

SL 150 / 200 / 250
 ZT 2500 FBT
 Goodway GS 200 / 260 / 280 M-ML-LMS
 CMZ TC 15 / 20 / 25 / 30 / 35
 CMZ TL 20 / 25

Bestell-Nr. Order Nr. Reference Sipariş Nr.	D1	Spannbereich Capacity Capacité Kapasite	A	A1	A2	E	H	L	L1	B	B1	B2	B3	K	S	N.Max (1/min)	T.Max. (Nm)	Kg	Euro
GW1RA32E32AB055	32	ER32 (2 - 20)	60	105	65	39	55	127	90	99	40	35	76	16	8	4000	50	9,50	

Zubehör / Accessories / Accessoires / Yedekler

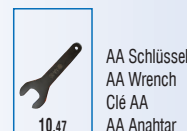



Axial Bohr - und Fräskopf Spannzangenaufnahme

Miyano BMT45

Axial drilling - milling head collet chuck

Tetè de percage - fraisage axiale mandrin pour pinces

Axial Tahrikli Takım Tutucu Pens Başlığı

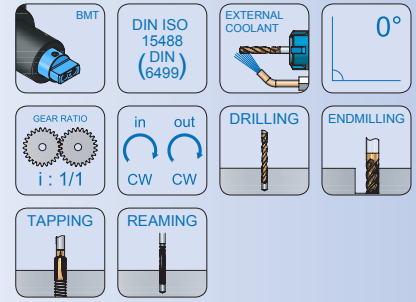
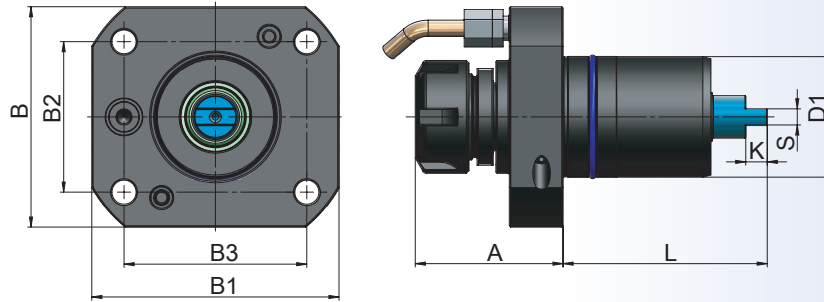

Goodway GLS 1500

Miyano ABX - 15 / 64

* Miyano BND - BNE - BNS 34 / 42 / 51

Bestell-Nr. Order Nr. Reference Sipariş Nr.	D1	Spannbereich Capacity Capacité Kapasite	A	L	B	B1	B2	B3	K	S	N.Max. (1/min)	T.Max. (Nm)	Kg	Euro
GW2AX45E25055	45	ER25 (2 - 16)	55	76	82	92	56	68	8	6	6000	50	1,85	

* Für Maschinen mit Produktionsdatum 2007 und jünger.

* For machines with production date 2007 and younger.

* Pour les machines avec date de production 2007 et plus jeune.

* Üretim tarihi 2007 ve sonrası olan tezgahlar içindir.

Radial Bohr - und Fräskopf Spannzangenaufnahme

Miyano BMT45

Radial drilling - milling head collet chuck

Tetè de percage - fraisage radiale mandrin pour pinces

Radial Tahrikli Takım Tutucu Pens Başlığı

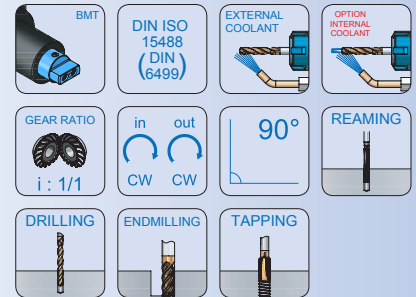
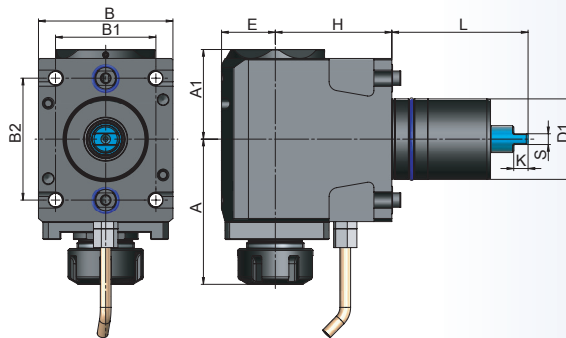

Goodway GLS 1500

Miyano ABX - 15 / 64

* Miyano BND - BNE - BNS 34 / 42 / 51

Bestell-Nr. Order Nr. Reference Sipariş Nr.	D1	Spannbereich Capacity Capacité Kapasite	A	A1	E	H	L	B	B1	B2	K	S	N.Max. (1/min)	T.Max. (Nm)	Kg	Euro
GW2RA45E25AB065	45	ER25 (2 - 16)	85	50,5	30	65	76	82	92	56	8	6	6000	50		

* Für Maschinen mit Produktionsdatum 2007 und jünger.

* For machines with production date 2007 and younger.

* Pour les machines avec date de production 2007 et plus jeune.

* Üretim tarihi 2007 ve sonrası olan tezgahlar içindir.

Zubehör / Accessories / Accessoires / Yedekler



DIN ISO 15488
Spannzangen System ER
Collets System ER
Pincés de serrage System ER
Pens ER



DIN ISO 15488
Spannmutter ER
Clamping nuts ER
Écrou de serrage ER
Pens kapağı ER



Spann Schlüssel ER
Wrench ER
Clé de serrage
Anahtar ER



AA Schlüssel
AA Wrench
Clé AA
AA Anahtar



Axial drilling - milling head collet chuck

Tête de perçage - fraisage axiale mandrin pour pinces

Axial Tahrikli Takım Tutucu Pens Başlığı

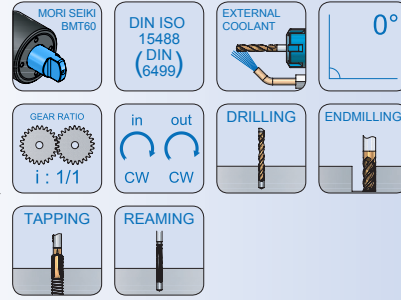
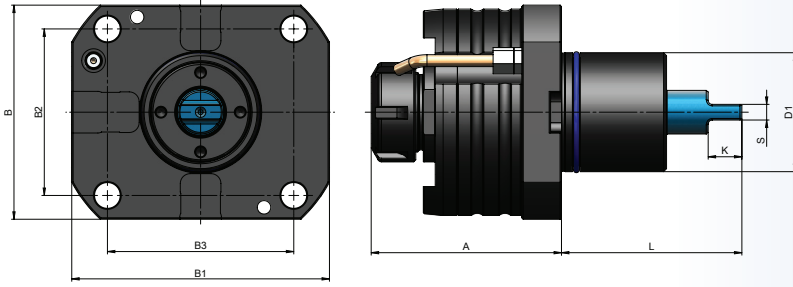

Bestell-Nr. Order Nr. Reference Sipariş Nr.	D1	Spannbereich Capacity Capacité Kapasite	A	L	B	B1	B2	B3	K	S	N.Max (1/min)	T.Max. (Nm)	Kg	Euro
MSAX40E25072	40	ER25 (2 - 16)	72	69	80	110	62	70	14	8	6000	40	2,40	
MSAX60E32096	60	ER32(2-20)	96	91	108	130	84	94	17	8	6000	100	5,75	
MSAX60E40100	60	ER32(2-20)	100	91	108	130	84	94	17	8	6000	100	5,95	

Zubehör / Accessories / Accessoires / Yedekler

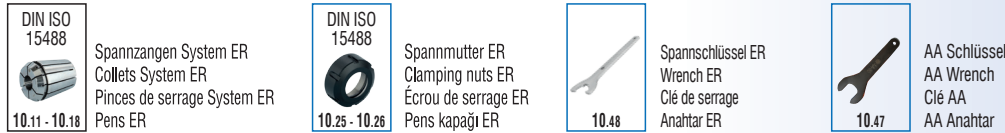

Axial Fräskopf Fräsdornaufnahme

Mori Seiki BMT40 / BMT60

Axial milling head chuck for cutter arbor

Tête de fraisage axiale porte - fraise

Axial Tahrikli Takım Tutucu Alın Kamalı Malafa

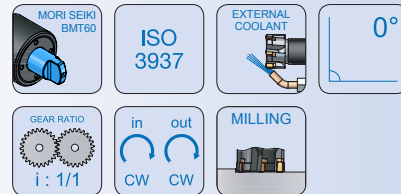
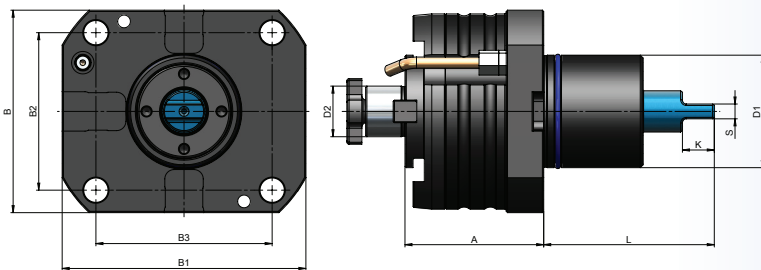

Bestell-Nr. Order Nr. Reference Sipariş Nr.	D1	D2	A	L	B	B1	B2	B3	K	S	N.Max (1/min)	T.Max. (Nm)	Kg	Euro
MSAX40K22054	40	22	54	69	80	110	62	70	14	8	6000	40	2,30	
MSAX60K22074	60	22	74	91	108	130	84	94	17	8	6000	100	6,25	
MSAX60K27074	60	27	74	91	108	130	84	94	17	8	6000	100	6,35	

Zubehör / Accessories / Accessoires / Yedekler





Radial Bohr - und Fräskopf Spannangenaufnahme

Mori Seiki BMT40 / BMT60

Radial drilling - milling head collet chuck

Tetè de percage - fraisage radiale mandrin pour pinces

Radial Tahrıklı Takım Tutucu Pens Başlıđı

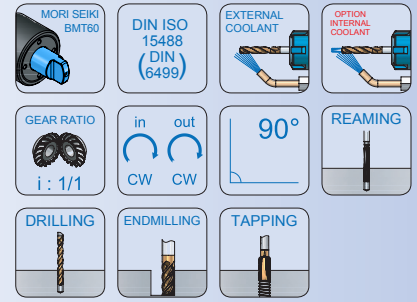
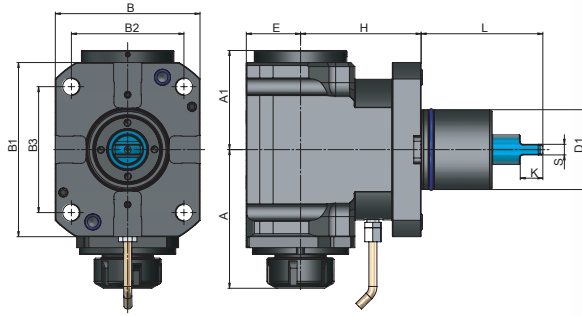

Bestell-Nr. Order Nr. Reference Sipariş Nr.	D1	Spannbereich Capacity Capacité Kapasite	A	A1	E	H	L	B	B1	B2	B3	K	S	N.Max (1/min)	T.Max. (Nm)	Kg	Euro
MSRA40E25AB085	40	ER25 (2 - 16)	110	55	38	85	69	82	110	62	70	14	8	6000	40	8,00	
MSRA60E32AB090	60	ER32 (2 - 20)	103,5	74	40,5	90	91	108	130	84	94	17	8	6000	100	10,60	
MSRA60E40AB090	60	ER40 (3 - 26)	107	74	40,5	90	91	108	130	84	94	17	8	6000	100		

Zubehör / Accessories / Accessoires / Yedekler



Spannmutter System ER
Collets System ER
Pincas de serrage System ER
Pens ER



Spannmutter ER
Clamping nuts ER
Écrou de serrage ER
Pens kapađı ER



Spannschlüssel ER
Wrench ER
Clé de serrage
Anahtar ER



AA Schlüssel
AA Wrench
Clé AA
AA Anahtar

Radial Fräskopf Fräsdornaufnahme

Mori Seiki BMT40 / BMT60

Radial milling head chuck for cutter arbor

Tetè de fraisage radiale porte - fraise

Radial Tahrıklı Takım Tutucu Alın Kamalı Malafı

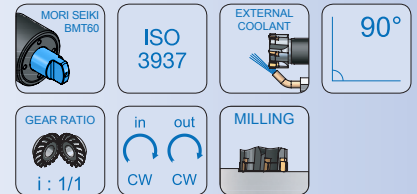
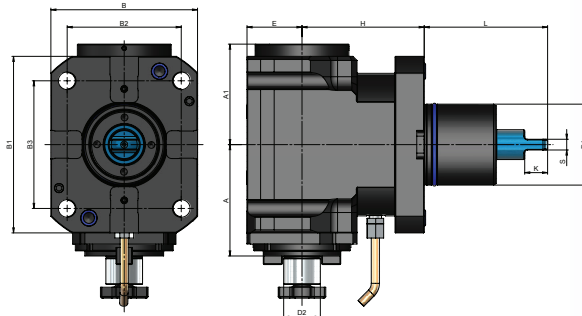

Bestell-Nr. Order Nr. Reference Sipariş Nr.	D1	D2	A	A1	E	H	L	B	B1	B2	B3	K	S	N.Max (1/min)	T.Max. (Nm)	Kg	Euro
MSRA40K22AB085	40	22	90	55	38	85	69	82	110	62	70	14	8	6000	40	8,10	
MSRA60K22AB090	60	22	81	74	40,5	90	91	108	130	84	94	17	8	6000	100		
MSRA60K27AB090	60	27	82	74	40,5	90	91	108	130	84	94	17	8	6000	100		

Zubehör / Accessories / Accessoires / Yedekler



Fräseranzugsschrauben
Drawn in bolt
Vis de serrage
Alın sıkma civatası



Mitnehmersteine
Drive keys
Entraîneur
Kama



Spannschlüssel für Aufsteckdorne
Wrench
Clé de serrage
Alın civatası sıkma anahtar



Axial drilling - milling head collet chuck

Tête de perçage - fraiseage axiale mandrin pour pinces

Axial Tahrikli Takım Tutucu Pens Başlığı

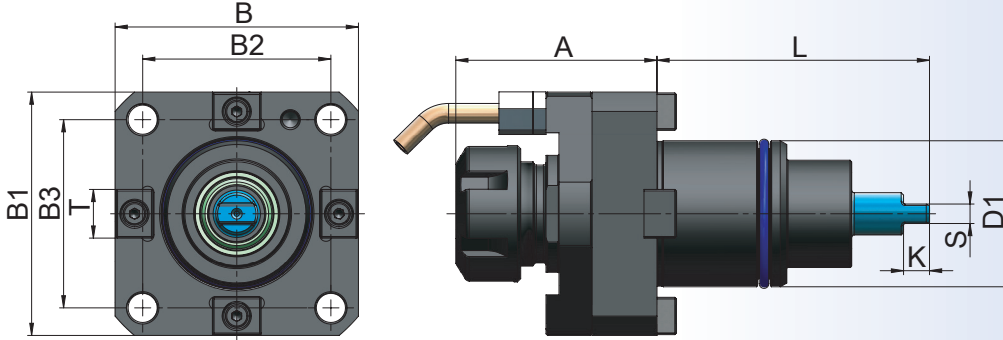
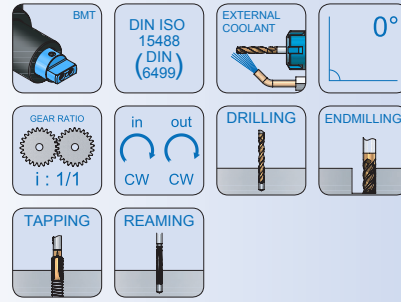

Bestell-Nr. Order Nr. Reference Sipariş Nr.	D1	Spannbereich Capacity Capacité Kapasite	A	L	T	B	B1	B2	B3	K	S	N.Max (1/min)	T.Max. (Nm)	Kg	Euro
BMTAX45E25062	45	ER25 (2 - 16)	62,5	84	15	75	75	58	58	8	6	6000	25	2,05	
BMTAX55E25062	55	ER25 (2 - 16)	62,5	104	15	85	85	64	64	10	8	6000	40	2,90	
BMTAX65E32085	65	ER32 (2 - 20)	85	112	18	94	94	73	70	14	10	4000	70	4,40	
BMTAX75E40115	75	ER40 (3 - 26)	115	110	25	112	112	90	90	15	14	3000	100	9,25	

Zubehör / Accessories / Accessoires / Yedekler

DIN ISO 15488

 Spannzangen System ER
 Collets System ER
 Pincés de serrage System ER
 Pens ER
 10.11 - 10.18

DIN ISO 15488

 Spannmutter ER
 Clamping nuts ER
 Écrou de serrage ER
 Pens kapağı ER
 10.25 - 10.26

 Spanschlüssel ER
 Wrench ER
 Clé de serrage
 Anahtar ER
 10.48

 AA Schlüssel
 AA Wrench
 Clé AA
 AA Anahtar
 10.47



Radial Bohr - und Fräskopf Spannzangenaufnahme

BMT 45-55-65-75

Radial drilling - milling head collet chuck

Tetè de perçage - fraisage radiale mandrin pour pinces

Radial Tahrikli Takım Tutucu Pens Başlığı

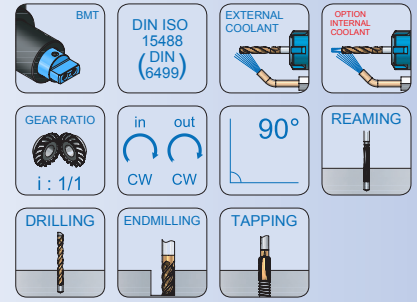
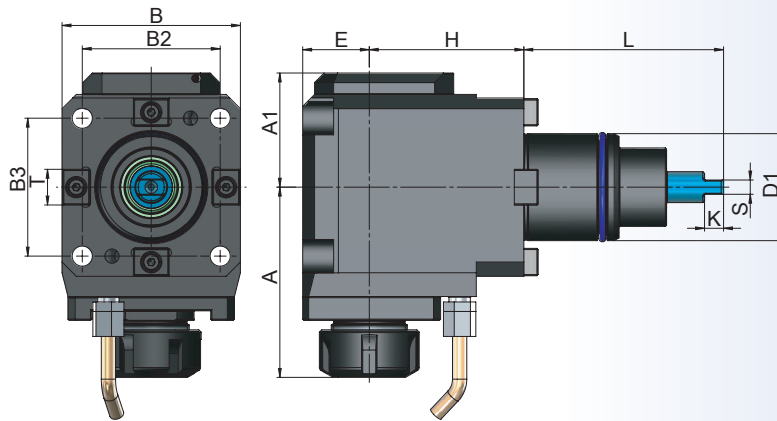

Bestell-Nr. Order Nr. Reference Sipariş Nr.	D1	Spannbereich Capacity Capacité Kapasite	A	A1	E	H	L	T	B	B2	B3	K	S	N.Max (1/min)	T.Max. (Nm)	Kg	Euro
BMTRA45E25AB065	45	ER25 (2 - 16)	80	48	28	65	84	15	75	58	58	8	6	6000	25	4,70	
BMTRA55E25AB070	55	ER25 (2 - 16)	80	55,5	30	70	104	15	85	64	64	10	8	6000	40	5,55	
BMTRA65E32AB072	65	ER32 (2 - 20)	95	54,5	38	72	112	18	94	73	70	14	10	4000	70	9,00	
BMTRA75E40AB060	75	ER40 (3 - 26)	100	65	47	60	110	25	112	90	90	15	14	3000	100	11,90	

Radial Bohr - und Fräskopf Spannzangenaufnahme - versetzt

BMT 45-55-65-75

Radial drilling - milling head collet chuck - shifted

Tetè de perçage - fraisage radiale mandrin pour pinces - décalé

Radial Tahrikli Takım Tutucu Pens Başlığı - Eksenden Kaçık

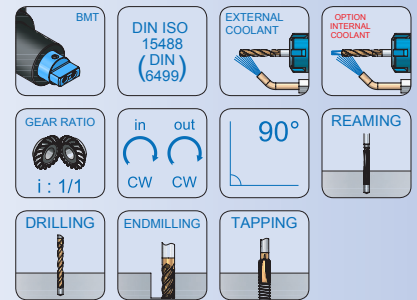
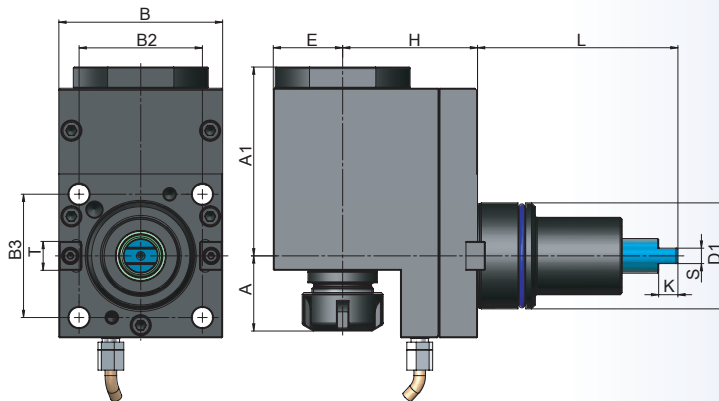

Bestell-Nr. Order Nr. Reference Sipariş Nr.	D1	Spannbereich Capacity Capacité Kapasite	A	A1	E	H	L	T	B	B2	B3	K	S	N.Max (1/min)	T.Max. (Nm)	Kg	Euro
BMTRK55E25AB070	55	ER25 (2 - 16)	40	97,5	36	70	104	15	85	64	64	10	8	6000	40		
BMTRK65E32AB086	65	ER32 (2 - 20)	55	97	38	86	112	18	94	73	70	14	10	4000	70		

Zubehör / Accessories / Accessoires / Yedekler



Spannzangen System ER
Collets System ER
Pincés de serrage System ER
Pens ER



Spannmutter ER
Clamping nuts ER
Écrou de serrage ER
Pens kapağı ER



Spann Schlüssel ER
Wrench ER
Clé de serrage
Anahtar ER



AA Schlüssel
AA Wrench
Clé AA
AA Anahtar

Axial Bohr - und Fräskopf Spannzangenaufnahme - versetzt

Mazak Nexus 200-250



Axial drilling - milling head collet chuck - shifted

Tetê de perçage - fraisage axiale mandrin pour pinces - décalé

Axial Tahrikli Takım Tutucu Pens Başlığı - Eksenden Kaçık

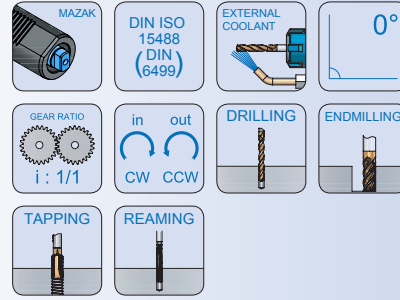
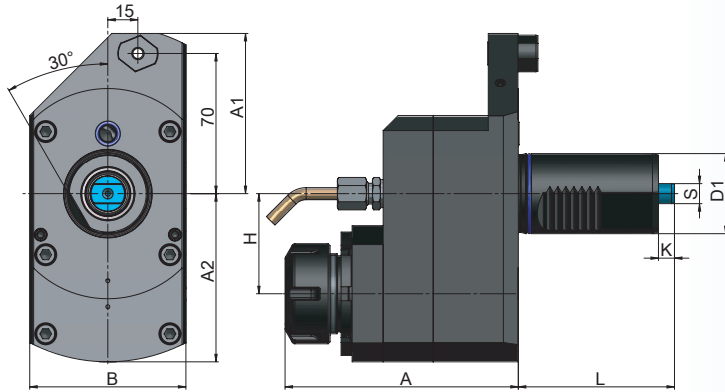

Bestell-Nr. Order Nr. Reference Sipariş Nr.	D1	Spannbereich Capacity Capacité Kapasite	A	A1	A2	H	L	B	K	S	N.Max. (1/min)	T.Max. (Nm)	Kg	Euro
MZ1AK40E32115C70	40	ER32 (2 - 20)	115	80	84	50	78	76	8	10	6000	70	6,00	

Radial Bohr - und Fräskopf Spannzangenaufnahme

Mazak Nexus 200-250

Radial drilling - milling head collet chuck

Tetê de perçage - fraisage radiale mandrin pour pinces

Radial Tahrikli Takım Tutucu Pens Başlığı

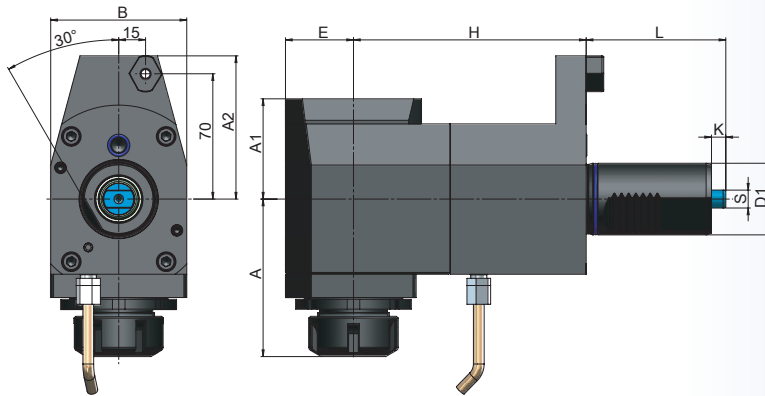

Bestell-Nr. Order Nr. Reference Sipariş Nr.	D1	Spannbereich Capacity Capacité Kapasite	A	A1	A2	E	H	L	B	K	S	N.Max. (1/min)	T.Max. (Nm)	Kg	Euro
MZ1RA40E32130C70	40	ER32 (2 - 20)	90	56	80	38	130	78	76	8	10	6000	70		

Zubehör / Accessories / Accessoires / Yedekler

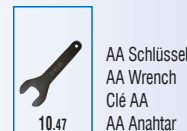
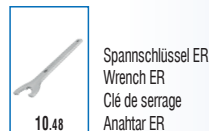

AGW
Driven Tools



Axial Bohr - und Fräskopf Spannzangenaufnahme - versetzt

Mazak Nexus 300-350

Axial drilling - milling head collet chuck - shifted

Tet  de perage - fraissage axiale mandrin pour pinces - d cal 

Axial Tahrikli Takım Tutucu Pens Bařlıđı - Eksenden Kaçık

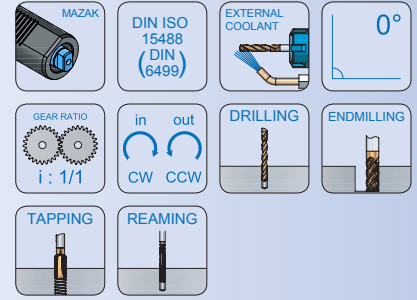
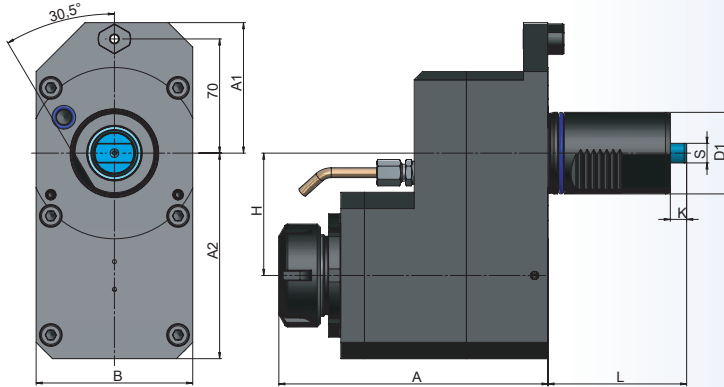

Bestell-Nr. Order Nr. Reference Sipariř Nr.	Spannbereich Capacity Capacit� Kapasite	D1	A	A1	A2	H	L	B	K	S	N.Max (1/min)	T.Max. (Nm)	Kg	Euro
MZ2AK50E40165C70	ER40 (3 - 26)	50	165	80	126	75	85	96	10	12	4000	100		

Radial Bohr - und Fräskopf Spannzangenaufnahme

Mazak Nexus 300-350

Radial drilling - milling head collet chuck

Tet  de perage - fraissage radiale mandrin pour pinces

Radial Tahrikli Takım Tutucu Pens Bařlıđı

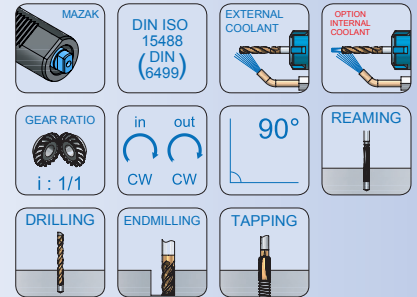
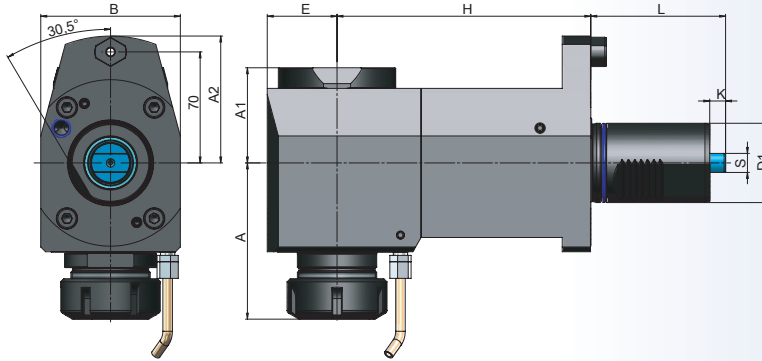

Bestell-Nr. Order Nr. Reference Sipariř Nr.	Spannbereich Capacity Capacit� Kapasite	D1	A	A1	A2	E	H	L	B	K	S	N.Max (1/min)	T.Max. (Nm)	Kg	Euro
MZ2RA50E40160C70	ER40 (3 - 26)	50	95	60	80	44	160	85	88	10	12	4000	100		

Zubeh r / Accessories / Accessoires / Yedekler



Spannzangen System ER
Collets System ER
Pinces de serrage System ER
Pens ER



Spannmutter ER
Clamping nuts ER
 crou de serrage ER
Pens kapađı ER



Spannchl ssel ER
Wrench ER
Cl  de serrage
Anahtar ER



AA Schl ssel
AA Wrench
Cl  AA
AA Anahtar

Axial Bohr - und Fräskopf Spannzangenaufnahme - versetzt

Mazak Nexus 100 MY



Axial drilling - milling head collet chuck - shifted

Tetê de perçage - fraisage axiale mandrin pour pinces - décalé

Axial Tahrikli Takım Tutucu Pens Başlığı - Eksenden Kaçık

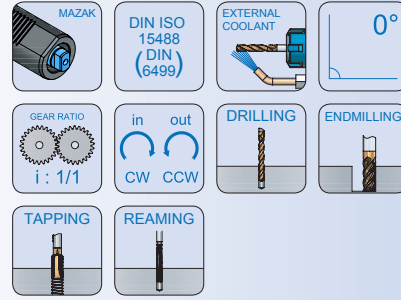
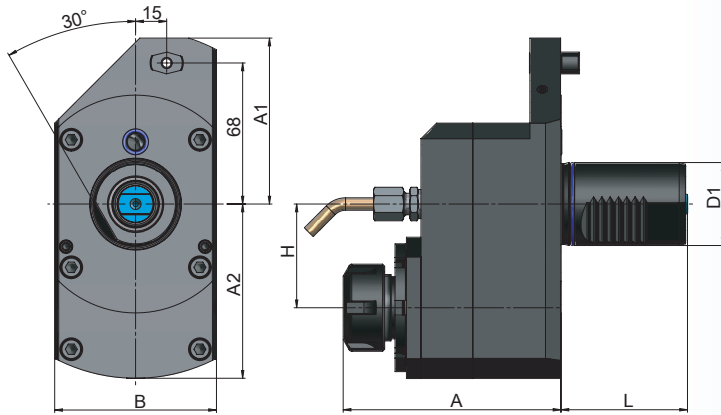

Bestell-Nr. Order Nr. Reference Sipariş Nr.	D1	Spannbereich Capacity Capacité Kapasite	A	A1	A2	H	L	B	K	S	N.Max. (1/min)	T.Max. (Nm)	Kg	Euro
MZ3AK40E25105C68	40	ER25 (2 - 16)	105	80	84	50	61	78	8	10	6000	70		
MZ3AK40E25115C68	40	ER25 (2 - 16)	115	80	84	50	61	78	8	10	6000	70		
MZ3AK40E32105C68	40	ER32 (2 - 20)	105	80	84	50	61	78	8	10	6000	70		
MZ3AK40E32115C68	40	ER32 (2 - 20)	115	80	84	50	61	78	8	10	6000	70		

Radial Bohr - und Fräskopf Spannzangenaufnahme

Mazak Nexus 100 MY

Radial drilling - milling head collet chuck

Tetê de perçage - fraisage radiale mandrin pour pinces

Radial Tahrikli Takım Tutucu Pens Başlığı

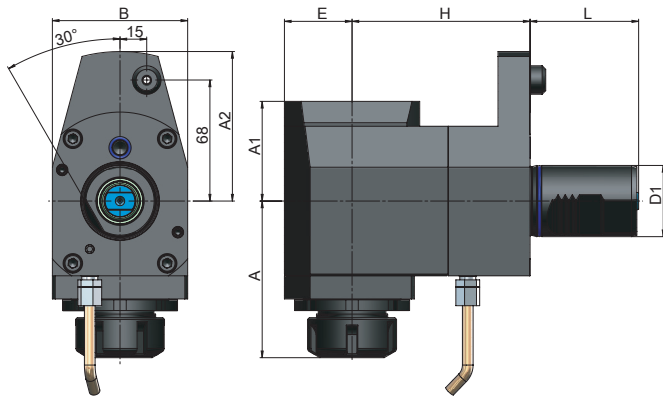

Bestell-Nr. Order Nr. Reference Sipariş Nr.	D1	Spannbereich Capacity Capacité Kapasite	A	A1	A2	E	H	L	B	K	S	N.Max. (1/min)	T.Max. (Nm)	Kg	Euro
MZ3RA40E32100C68	40	ER32 (2 - 20)	87	56	84	38	100	61	76	8	10	6000	100		

Zubehör / Accessories / Accessoires / Yedekler

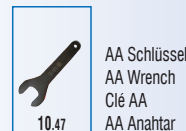



Axial Bohr - und Fräskopf Spannzangenaufnahme

Mazak MP 420/620/625/6200/6250

Axial drilling - milling head collet chuck

Tetè de perçage - fraisage axiale mandrin pour pinces

Axial Tahrikli Takım Tutucu Pens Başlığı

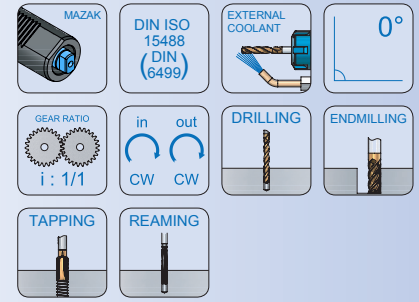
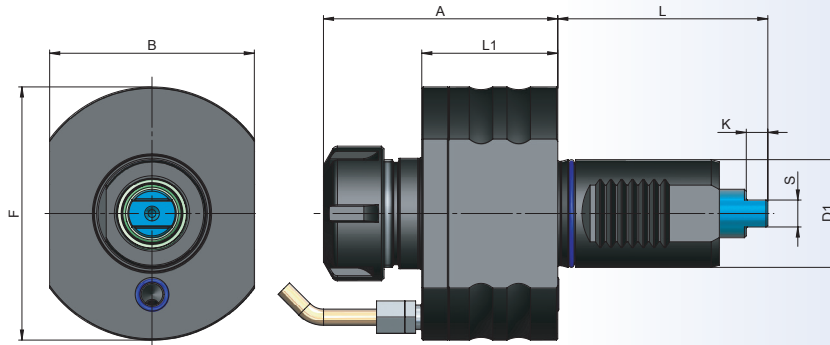

Bestell-Nr. Order Nr. Reference Sipariş Nr.	D1	Spannbereich Capacity Capacité Kapasite	A	L	L1	B	F	K	S	N.Max. (1/min)	T.Max. (Nm)	Kg	Euro
MZ4AX40E32087	40	ER32 (2 - 20)	87	78	50,5	76	94	8	10	6000	25	3,20	

Radial Bohr - und Fräskopf Spannzangenaufnahme

Mazak MP 420/620/625/6200/6250

Radial drilling - milling head collet chuck

Tetè de perçage - fraisage radiale mandrin pour pinces

Radial Tahrikli Takım Tutucu Pens Başlığı

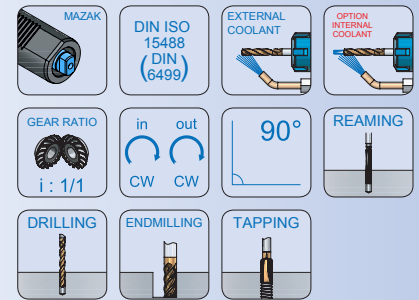
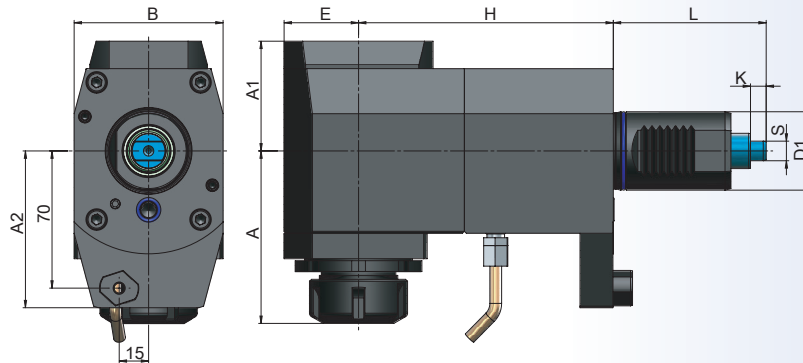

Bestell-Nr. Order Nr. Reference Sipariş Nr.	D1	Spannbereich Capacity Capacité Kapasite	A	A1	A2	E	H	L	B	K	S	N.Max. (1/min)	T.Max. (Nm)	Kg	Euro
MZ4RA40E32130C70	40	ER32 (2 - 20)	88	55	56	38	130	78	76	8	10	6000	25	8,85	

Zubehör / Accessories / Accessoires / Yedekler



Spannzangen System ER
Collets System ER
Pincés de serrage System ER
Pens ER



Spannmutter ER
Clamping nuts ER
Écrou de serrage ER
Pens kapağı ER



Spann Schlüssel ER
Wrench ER
Clé de serrage
Anahtar ER



AA Schlüssel
AA Wrench
Clé AA
AA Anahtar



Axial drilling - milling head collet chuck

Tête de perçage - fraisage axiale mandrin pour pinces

Axial Tahrikli Takım Tutucu Pens Başlığı

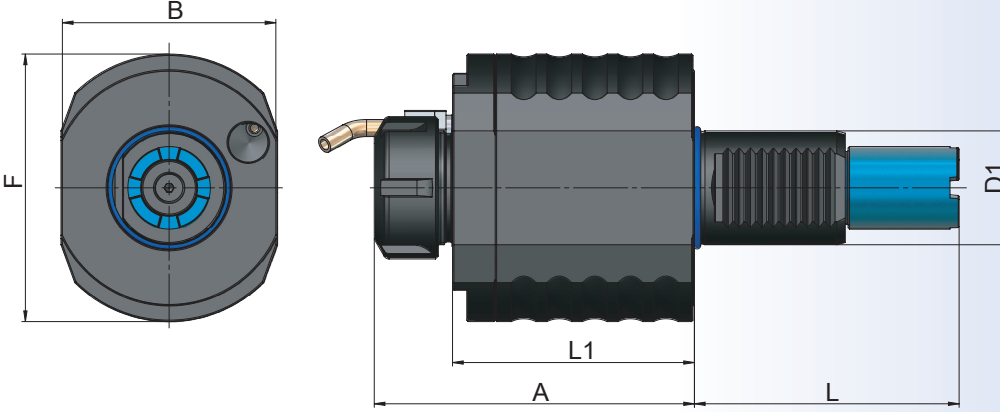
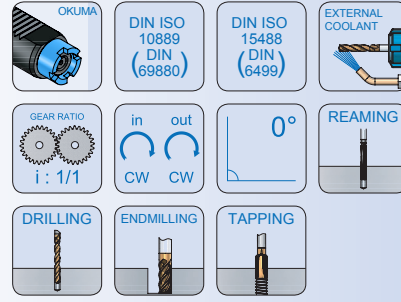

Bestell-Nr. Order Nr. Reference Sipariş Nr.	D1	Spannbereich Capacity Capacité Kapasite	A	L	L1	B	F	N.Max (1/min)	T.Max. (Nm)	Kg	Euro
O1AX30E25090	30	ER25 (2 - 16)	90	69	58	62	70	6000	40	2,50	
O2AX40E32112	40	ER32 (2 - 20)	112,5	93	76	76	94	6000	50		
O3AX50E32112	40	ER32 (2 - 20)	112,5	101	76	76	94	6000	50		
O4AX40E32112	40	ER32 (2 - 20)	112,5	93	76	76	94	6000	50		

Zubehör / Accessories / Accessoires / Yedekler

DIN ISO 15488

 Spannzangen System ER
 Collets System ER
 Pincés de serrage System ER
 Pens ER
 10.11 - 10.18

DIN ISO 15488

 Spannmutter ER
 Clamping nuts ER
 Écrou de serrage ER
 Pens kapağı ER
 10.25 - 10.26

 Spannschlüssel ER
 Wrench ER
 Clé de serrage
 Anahtar ER
 10.48



 AA Schlüssel
 AA Wrench
 Clé AA
 AA Anahtar
 10.47



Radial drilling - milling head collet chuck

Tête de perçage - fraisage radiale mandrin pour pinces

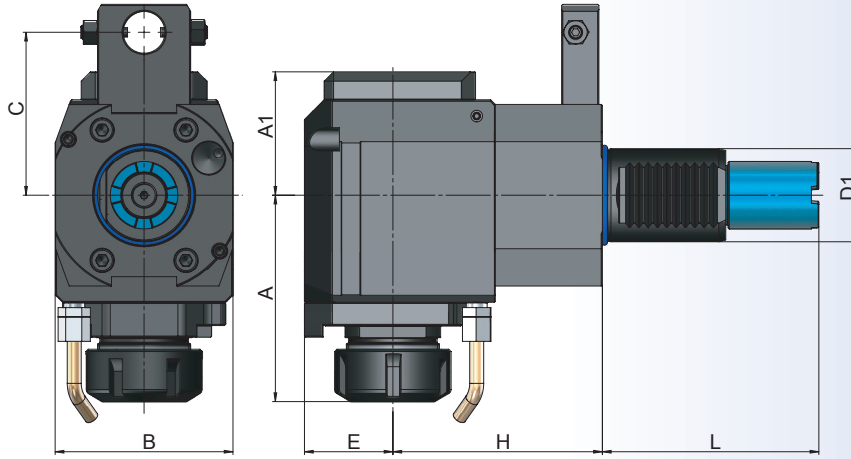
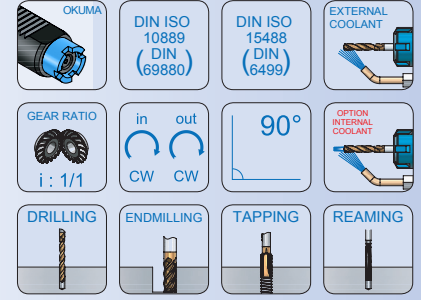
Radial Tahrikli Takım Tutucu Pens Başlığı



Bestell-Nr. Order Nr. Reference Sipariş Nr.	D1	Spannbereich Capacity Capacité Kapasite	A	A1	E	H	L	B	C	N.Max (1/min)	T.Max. (Nm)	Kg	Euro
O1RA30E25A090C63	30	ER25 (2 - 16)	67	41	26	90	69	64	63	6000	40	3,85	
O1RA30E25B090C63	30	ER25 (02 - 16)	67	41	26	90	69	64	63	6000	40	3,85	
O2RA40E32A090C70	40	ER32 (2 - 20)	85	53	38	90	93	76	70	5000	70	6,68	
O2RA40E32B090C70	40	ER32 (2 - 20)	85	53	38	90	93	76	70	5000	70	6,68	
O3RA40E32A090C70	40	ER32 (2 - 20)	85	53	38	90	101	76	70	5000	70		
O3RA40E32B090C70	40	ER32 (2 - 20)	85	53	38	90	101	76	70	5000	70		
O4RA40E32A090C90	40	ER32 (2 - 20)	85	53	38	90	93	76	90	5000	70	6,68	
O4RA40E32B090C90	40	ER32 (2 - 20)	85	53	38	90	93	76	90	5000	70	6,68	

Zubehör / Accessories / Accessoires / Yedekler



Spannzangen System ER
Collets System ER
Pincés de serrage System ER
Pens ER



Spannmutter ER
Clamping nuts ER
Écrou de serrage ER
Pens kapağı ER



Spann Schlüssel ER
Wrench ER
Clé de serrage
Anahtar ER



AA Schlüssel
AA Wrench
Clé AA
AA Anahtar



Radial drilling - milling head collet chuck - shifted

Tête de perçage - fraisage radiale mandrin pour pinces - décalé

Radial Tahrikli Takım Tutucu Pens Başlığı - Eksenden Kaçık

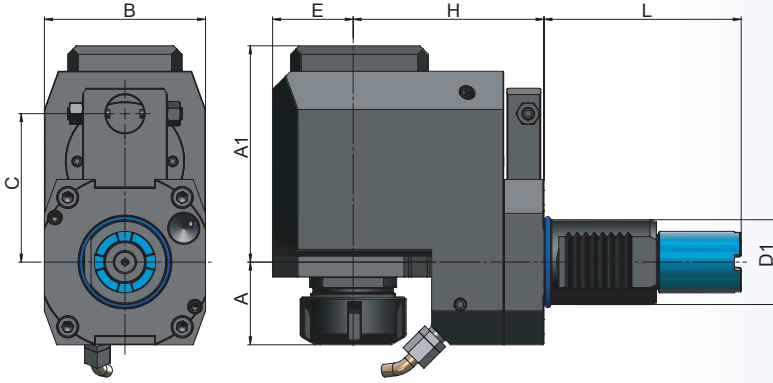
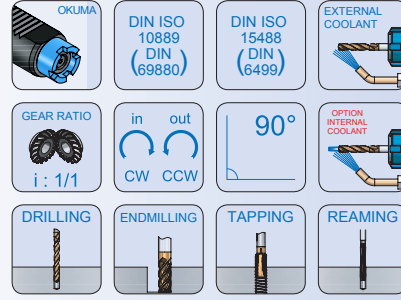

Bestell-Nr. Order Nr. Reference Sipariş Nr.	D1	Spannbereich Capacity Capacité Kapasite	A	A1	E	H	L	B	C	N.Max. (1/min)	T.Max. (Nm)	Kg	Euro
O1RK30E25A070C63	30	ER25 (02 - 16)	25	84	26	70	69	64	63	6000	40	3,85	
O1RK30E25B070C63	30	ER25 (02 - 16)	25	84	26	70	69	64	63	6000	40	3,85	
O2RK40E32A090C70	40	ER32 (2 - 20)	35	99,5	38	90	93	76	70	4000	70		
O2RK40E32B090C70	40	ER32 (2 - 20)	35	99,5	38	90	93	76	70	4000	70		
O3RK40E32A090C70	40	ER32 (2 - 20)	35	99,5	38	90	101	76	70	5000	70		
O3RK40E32B090C70	40	ER32 (2 - 20)	35	99,5	38	90	101	76	70	5000	70		

Zubehör / Accessories / Accessoires / Yedekler

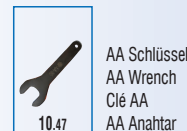
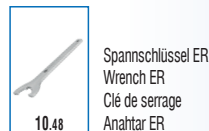



Radial Bohr - und Fräskopf Spannzangenaufnahme - versetzt

Okuma LT 300 M

Radial drilling - milling head collet chuck - shifted

Têté de perçage - fraissage radiale mandrin pour pinces - décalé

Radial Tahrikli Takım Tutucu Pens Başlığı - Eksenden Kaçık

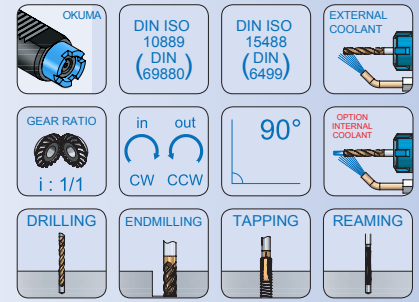
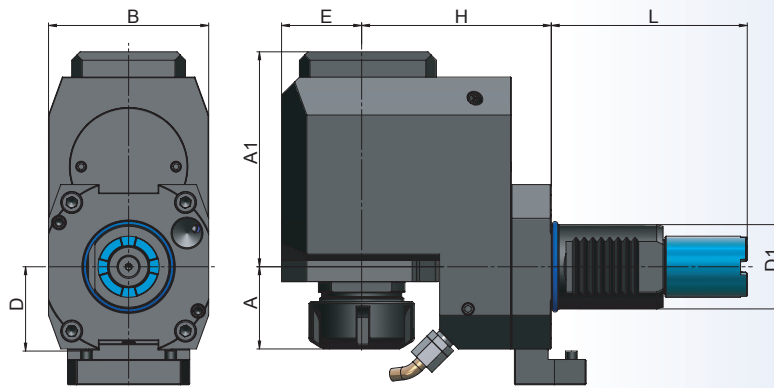

Bestell-Nr. Order Nr. Reference Sipariş Nr.	D1	Spannbereich Capacity Capacité Kapasite	A	A1	E	H	L	B	D	N.Max (1/min)	T.Max. (Nm)	Kg	Euro
O2RK40E32A090D50	40	ER32 (2 - 20)	35	99,5	38	90	93	76	50	4000	70		
O2RK40E32B090D50	40	ER32 (2 - 20)	35	99,5	38	90	93	76	50	4000	70		

Radial Bohr - und Fräskopf Spannzangenaufnahme

Okuma LT 300 M

Radial drilling - milling head collet chuck

Têté de perçage - fraissage radiale mandrin pour pinces

Radial Tahrikli Takım Tutucu Pens Başlığı

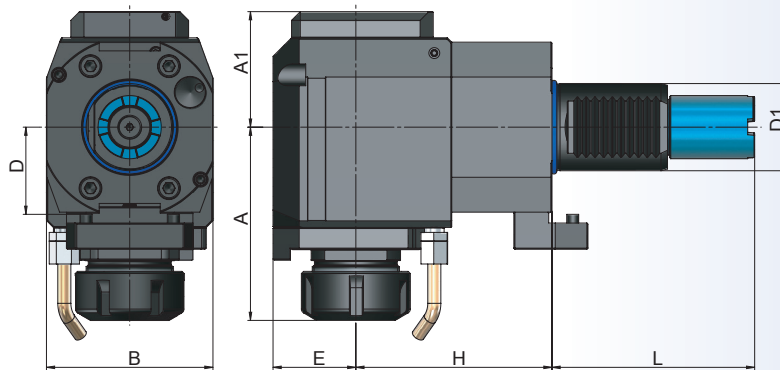

Bestell-Nr. Order Nr. Reference Sipariş Nr.	D1	Spannbereich Capacity Capacité Kapasite	A	A1	E	H	L	B	D	N.Max (1/min)	T.Max. (Nm)	Kg	Euro
O2RA40E32A090D50	40	ER32 (2 - 20)	85	53	38	90	93	76	50	5000	70		
O2RA40E32B090D50	40	ER32 (2 - 20)	85	53	38	90	93	76	50	5000	70		

Zubehör / Accessories / Accessoires / Yedekler



Spannzangen System ER
Collets System ER
Pincés de serrage System ER
Pens ER



Spannmutter ER
Clamping nuts ER
Écrou de serrage ER
Pens kapağı ER



Spannschlüssel ER
Wrench ER
Clé de serrage
Anahtar ER



AA Schlüssel
AA Wrench
Clé AA
AA Anahtar

Axial Bohr - und Fräskopf Spannzangenaufnahme

Okuma LB 2000 / 2500 / 3000



Axial drilling - milling head collet chuck

Tête de perçage - fraisage axiale mandrin pour pinces

Axial Tahrikli Takım Tutucu Pens Başlığı

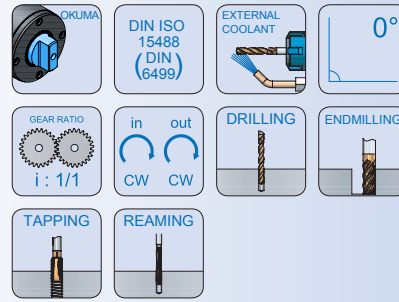
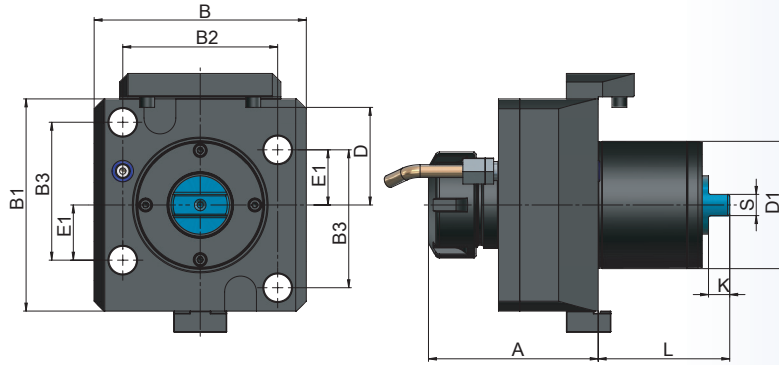

Bestell-Nr. Order Nr. Reference Sipariş Nr.	Spannbereich Capacity Capacité Kapasite	A	E1	L	B	B1	B2	B3	D	K	S	N.Max (1/min)	T.Max. (Nm)	Kg	Euro
O5AX60E32080	ER32 (2 - 20)	80	26	62	97	100	73	65	50	13	10	6000	70		

Radial Bohr - und Fräskopf Spannzangenaufnahme

Okuma LB 2000 / 2500 / 3000

Radial drilling - milling head collet chuck

Tête de perçage - fraisage radiale mandrin pour pinces

Radial Tahrikli Takım Tutucu Pens Başlığı

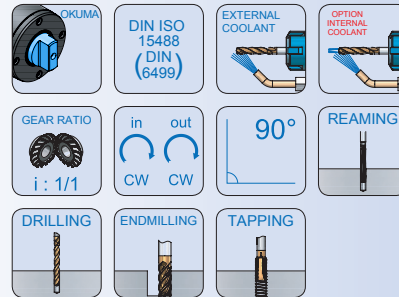
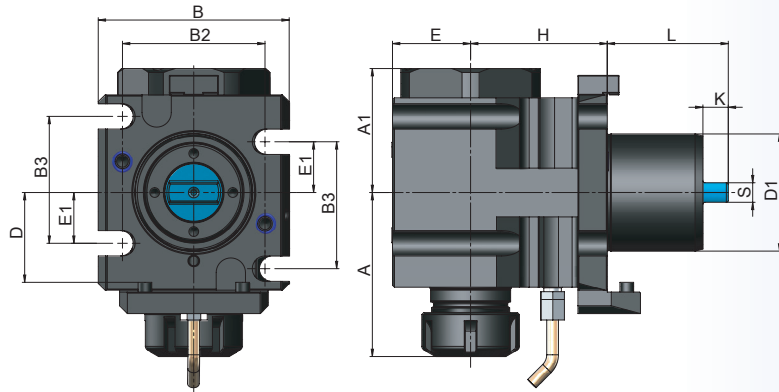

Bestell-Nr. Order Nr. Reference Sipariş Nr.	Spannbereich Capacity Capacité Kapasite	A	A1	E	E1	H	L	B	B2	B3	D	K	S	N.Max (1/min)	T.Max. (Nm)	Kg	Euro
O5RA60E32AB070	ER32 (2 - 20)	80	63,5	40	26	70	62	98	73	65	50	13	10	6000	70		

Zubehör / Accessories / Accessoires / Yedekler

DIN ISO 15488
Spannzangen System ER
Collets System ER
Pincés de serrage System ER
Pens ER
10.11 - 10.18

DIN ISO 15488
Spannmutter ER
Clamping nuts ER
Écrou de serrage ER
Pens kapağı ER
10.25 - 10.26

Spannschlüssel ER
Wrench ER
Clé de serrage
Anahtar ER
10.48

AA Schlüssel
AA Wrench
Clé AA
AA Anahtar
10.47



Axial Bohr - und Fräskopf Spannzangenaufnahme

Okuma LB 4000

Axial drilling - milling head collet chuck

Tetè de perçage - fraisage axiale mandrin pour pinces

Axial Tahrikli Takım Tutucu Pens Başlığı

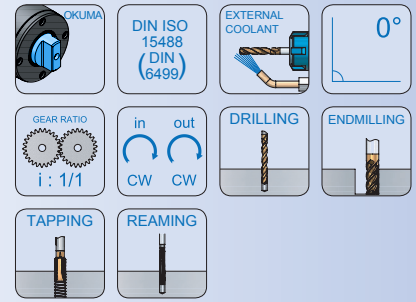
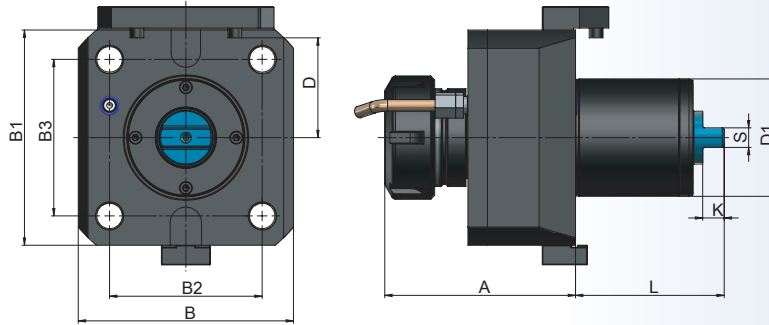

Bestell-Nr. Order Nr. Reference Sipariş Nr.	D1	Spannbereich Capacity Capacité Kapasite	A	L	B	B1	B2	B3	D	K	S	N.Max (1/min)	T.Max. (Nm)	Kg	Euro
O6AX60E40095	60	ER32 (3 - 26)	95	76	110	110	78	80	55	11	10	6000	100		

Radial Bohr - und Fräskopf Spannzangenaufnahme

Okuma LB 4000

Radial drilling - milling head collet chuck

Tetè de perçage - fraisage radiale mandrin pour pinces

Radial Tahrikli Takım Tutucu Pens Başlığı

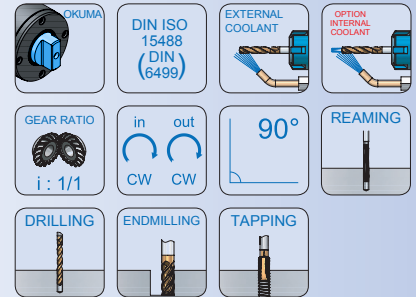
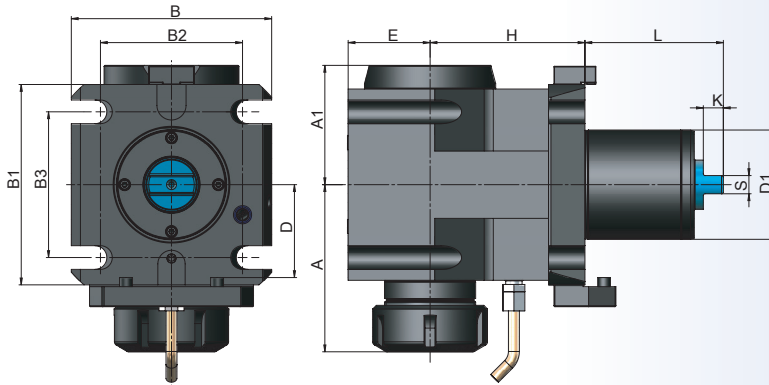

Bestell-Nr. Order Nr. Reference Sipariş Nr.	D1	Spannbereich Capacity Capacité Kapasite	A	A1	E	H	L	B	B1	B2	B3	D	K	S	N.Max (1/min)	T.Max. (Nm)	Kg	Euro
O6RA60E40AB085	60	ER40 (3 - 26)	92	65	45	85	76	110	110	78	80	55	11	10	6000	100		

Zubehör / Accessories / Accessoires / Yedekler



Spannzangen System ER
Collets System ER
Pincés de serrage System ER
Pens ER



Spannmutter ER
Clamping nuts ER
Écrou de serrage ER
Pens kapağı ER



Spannschlüssel ER
Wrench ER
Clé de serrage
Anahtar ER



AA Schlüssel
AA Wrench
Clé AA
AA Anahtar

Axial Bohr - und Fräskopf Spannzangenaufnahme

Okuma LT 2000 EX V16



Axial drilling - milling head collet chuck

Tête de perçage - fraisage axiale mandrin pour pinces

Axial Tahrikli Takım Tutucu Pens Başlığı

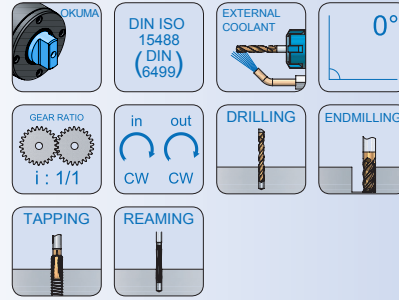
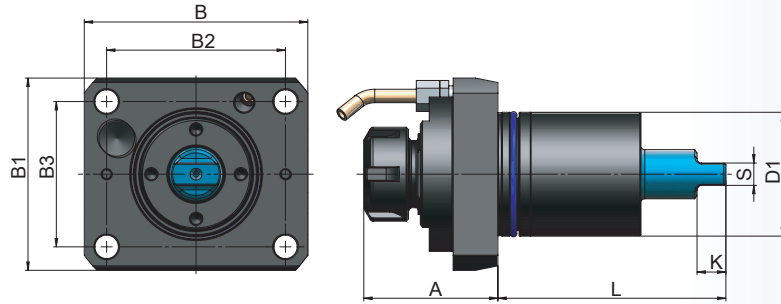

Bestell-Nr. Order Nr. Reference Sipariş Nr.	D1	Spannbereich Capacity Capacité Kapasite	A	L	B	B1	B2	B3	K	S	N.Max (1/min)	T.Max. (Nm)	Kg	Euro
new O7AX55E25060	55	ER25 (2 - 16)	60	102	86	100	65	80	13	10	6000	70		

Radial Bohr - und Fräskopf Spannzangenaufnahme

Okuma LT 2000 EX V16

Radial drilling - milling head collet chuck

Tête de perçage - fraisage radiale mandrin pour pinces

Radial Tahrikli Takım Tutucu Pens Başlığı

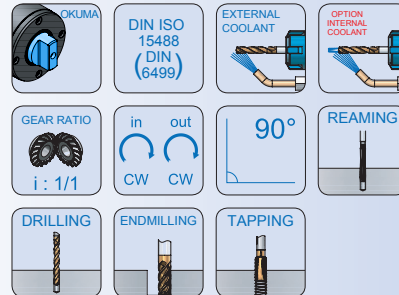
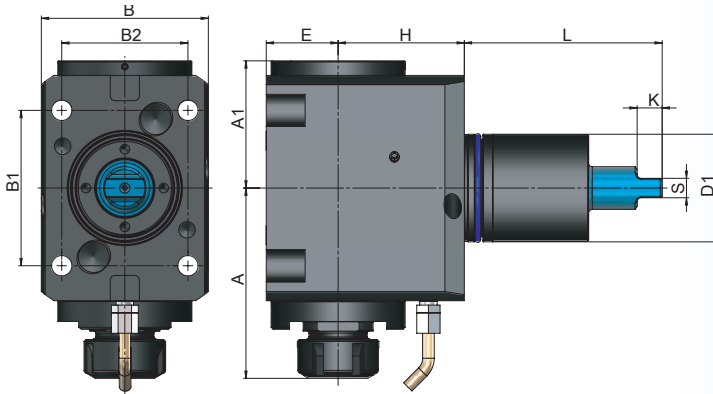

Bestell-Nr. Order Nr. Reference Sipariş Nr.	D1	Spannbereich Capacity Capacité Kapasite	A	A1	E	H	L	B	B1	B2	K	S	N.Max (1/min)	T.Max. (Nm)	Kg	Euro
new O7RA55E25AB065	55	ER25 (2 - 16)	98	65,5	37	65	102	86	65	80	13	10	6000	70		

Zubehör / Accessories / Accessoires / Yedekler

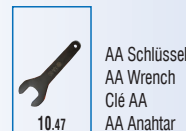

AGW
Driven Tools



Axial Bohr - und Fräskopf Spannzangenaufnahme

Takizawa EX 308 / 310 / 508 / 510

Axial drilling - milling head collet chuck

Tetè de perçage - fraisage axiale mandrin pour pinces

Axial Tahrikli Takım Tutucu Pens Başlığı

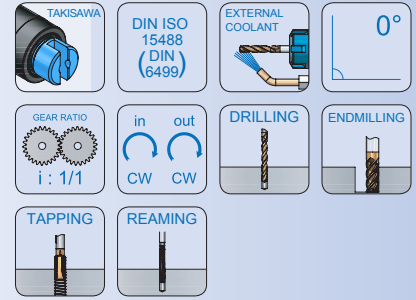
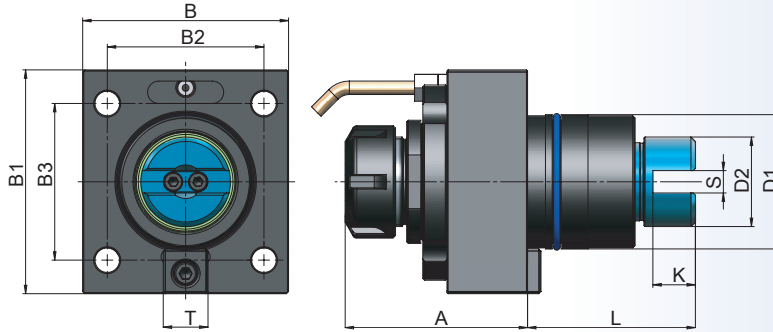

Bestell-Nr. Order Nr. Reference Sipariş Nr.	D1	Spannbereich Capacity Capacité Kapasite	D2	A	L	T	B	B1	B2	B3	K	S	N.Max (1/min)	T.Max. (Nm)	Kg	Euro
TS1AX60E32080	60	ER32 (3 - 26)	40	80	75	20	92	100	70	70	19	10	6000	50	4,30	

Radial Bohr - und Fräskopf Spannzangenaufnahme

Takizawa EX 308 / 310 / 508 / 510

Radial drilling - milling head collet chuck

Tetè de perçage - fraisage radiale mandrin pour pinces

Radial Tahrikli Takım Tutucu Pens Başlığı

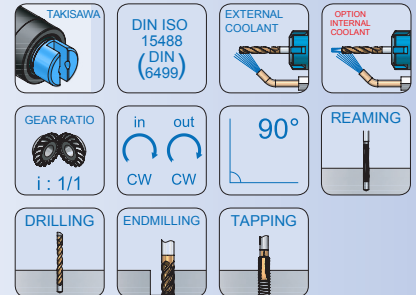
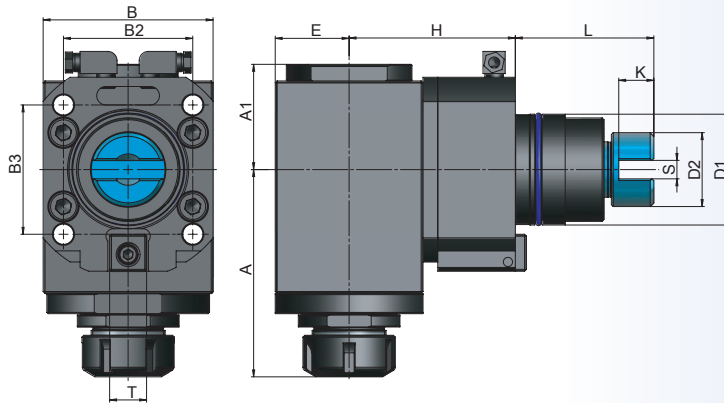

Bestell-Nr. Order Nr. Reference Sipariş Nr.	D1	Spannbereich Capacity Capacité Kapasite	A	A1	E	H	L	T	B	B2	B3	K	S	N.Max (1/min)	T.Max. (Nm)	Kg	Euro
TS1RA60E32AB090	60	ER40 (3 - 26)	111,5	62	40	90	75	20	92	70	70	19	10	6000	50	11,00	

Zubehör / Accessories / Accessoires / Yedekler



Spannzangen System ER
Collets System ER
Pincès de serrage System ER
Pens ER



Spannmutter ER
Clamping nuts ER
Écrou de serrage ER
Pens kapağı ER



Spannschlüssel ER
Wrench ER
Clé de serrage
Anahtar ER



AA Schlüssel
AA Wrench
Clé AA
AA Anahtar

Axial Bohr - und Fräskopf Spannzangenaufnahme

Takisawa TY 2000



Axial drilling - milling head collet chuck

Tête de perçage - fraisage axiale mandrin pour pinces

Axial Tahrikli Takım Tutucu Pens Başlığı

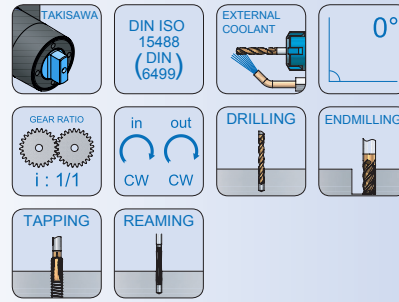
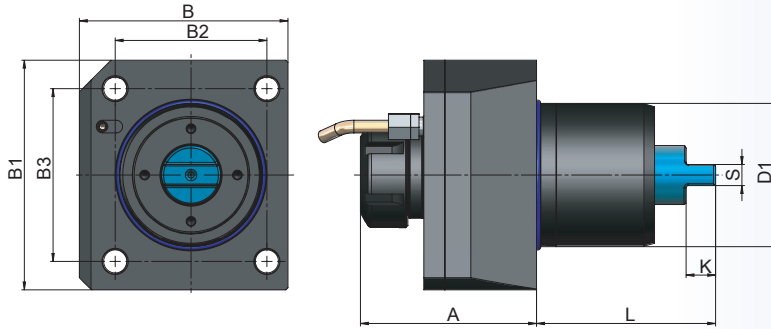

Bestell-Nr. Order Nr. Reference Sipariş Nr.	D1	Spannbereich Capacity Capacité Kapasite	A	L	B	B1	B2	B3	K	S	N.Max (1/min)	T.Max. (Nm)	Kg	Euro
TS2AX68E32086	68	ER32 (2 - 20)	80	85	109	99	82	72	14	10	6000	100	6,00	

Radial Bohr - und Fräskopf Spannzangenaufnahme

Takisawa TY 2000

Radial drilling - milling head collet chuck

Tête de perçage - fraisage radiale mandrin pour pinces

Radial Tahrikli Takım Tutucu Pens Başlığı

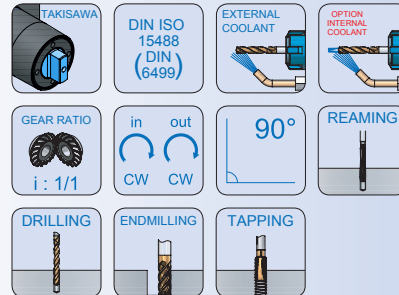
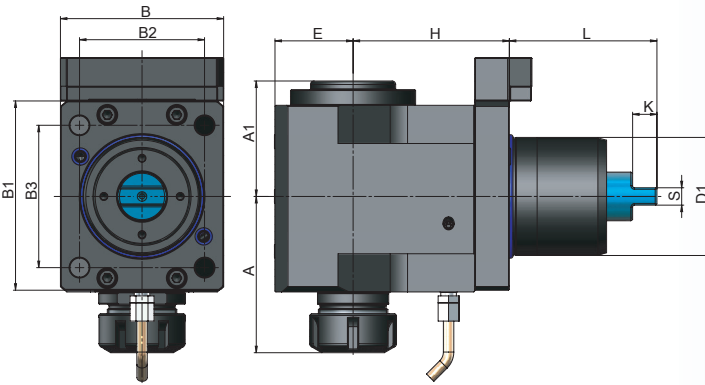

Bestell-Nr. Order Nr. Reference Sipariş Nr.	D1	Spannbereich Capacity Capacité Kapasite	A	A1	E	H	L	B	B1	B2	B3	K	S	N.Max (1/min)	T.Max. (Nm)	Kg	Euro
TS2RA68E32090	68	ER32 (2 - 20)	86,5	66,5	45	90	85	135	93,5	82	72	14	10	6000	100		

Zubehör / Accessories / Accessoires / Yedekler

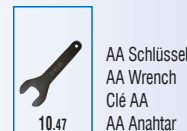
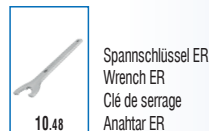



Axial Bohr - und Fräskopf Spannzangenaufnahme

Takisawa TC 250

Axial drilling - milling head collet chuck

Tetè de perçage - fraisage axiale mandrin pour pinces

Axial Tahrikli Takım Tutucu Pens Başlığı

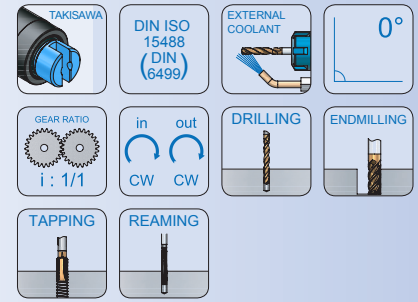
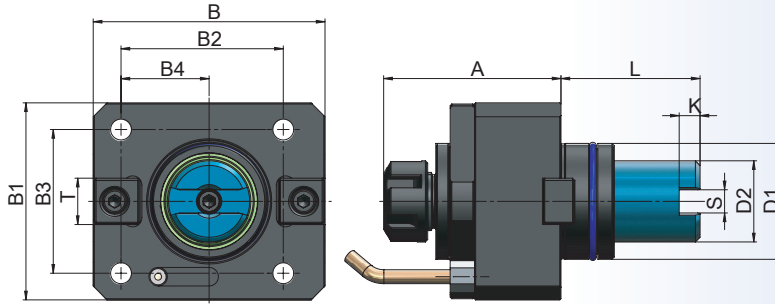

Bestell-Nr. Order Nr. Reference Sipariş Nr.	D1	Spannbereich Capacity Capacité Kapasite	D2	A	L	T	B	B1	B2	B3	B4	K	S	N.Max (1/min)	T.Max. (Nm)	Kg	Euro
TS3AX50E20075	50	ER20 (2 - 13)	35	75	60	20	100	85	70	62	38	9	10	6000	30	3,60	

Radial Bohr - und Fräskopf Spannzangenaufnahme

Takisawa TC 250

Radial drilling - milling head collet chuck

Tetè de perçage - fraisage radiale mandrin pour pinces

Radial Tahrikli Takım Tutucu Pens Başlığı

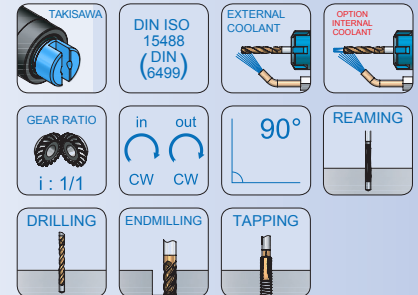
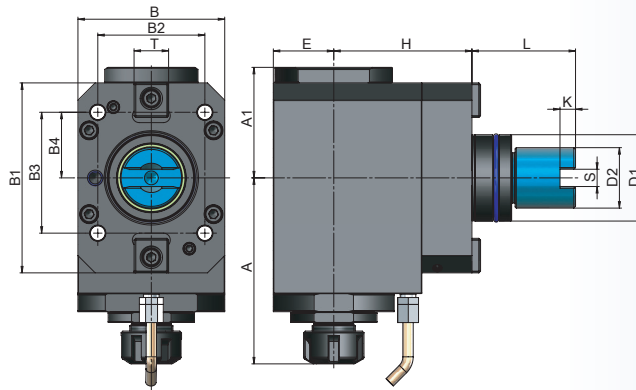

Bestell-Nr. Order Nr. Reference Sipariş Nr.	D1	Spannbereich Capacity Capacité Kapasite	D2	A	A1	E	H	L	T	B	B1	B2	B3	B4	K	S	N.Max (1/min)	T.Max. (Nm)	Kg	Euro
TS3RA50E20AB080	50	ER20 (2 - 13)	35	160	64	35	80	60	20	85	110	62	70	38	9	10	6000	50		

Zubehör / Accessories / Accessoires / Yedekler



Spannzangen System ER
Collets System ER
Pincés de serrage System ER
Pens ER

10.11 - 10.18



Spannmutter ER
Clamping nuts ER
Écrou de serrage ER
Pens kapağı ER

10.25 - 10.26



Spannschlüssel ER
Wrench ER
Clé de serrage
Anahtar ER

10.48



AA Schlüssel
AA Wrench
Clé AA
AA Anahtar

10.47

Axial Bohr - und Fräskopf Spannzangenaufnahme

Takisawa TS 4000Y



Axial drilling - milling head collet chuck

Tête de perçage - fraisage axiale mandrin pour pinces

Axial Tahrikli Takım Tutucu Pens Başlığı

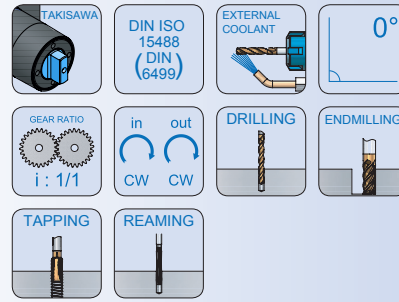
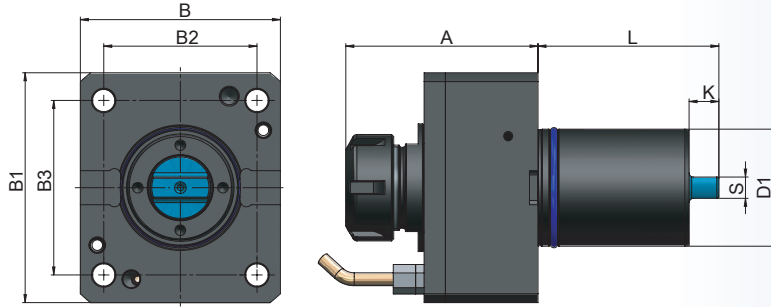

Bestell-Nr. Order Nr. Reference Sipariş Nr.	D1	Spannbereich Capacity Capacité Kapasite	A	L	B	B1	B2	B3	K	S	N.Max (1/min)	T.Max. (Nm)	Kg	Euro
new TS4AX55E32088	55	ER32 (2 - 20)	88	85	94	108	72	82	14	10	6000	70	3,56	

Radial Bohr - und Fräskopf Spannzangenaufnahme

Takisawa TY 2000

Radial drilling - milling head collet chuck

Tête de perçage - fraisage radiale mandrin pour pinces

Radial Tahrikli Takım Tutucu Pens Başlığı

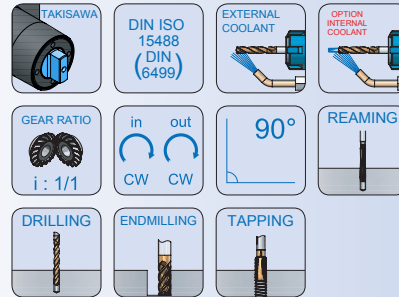
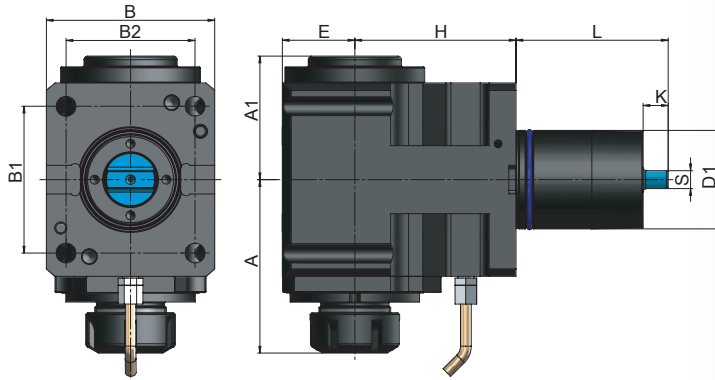

Bestell-Nr. Order Nr. Reference Sipariş Nr.	D1	Spannbereich Capacity Capacité Kapasite	A	A1	E	H	L	B	B1	B2	K	S	N.Max (1/min)	T.Max. (Nm)	Kg	Euro
new TS4RA55E32AB90	55	ER32 (2 - 20)	100	69	40,5	90	85	94	72	82	14	10	6000	70	9,60	

Zubehör / Accessories / Accessoires / Yedekler

DIN ISO 15488
Spannzangen System ER
Collets System ER
Pincés de serrage System ER
Pens ER
10.11 - 10.18

DIN ISO 15488
Spannmutter ER
Clamping nuts ER
Écrou de serrage ER
Pens kapağı ER
10.25 - 10.26

Spannschlüssel ER
Wrench ER
Clé de serrage
Anahtar ER
10.48

AA Schlüssel
AA Wrench
Clé AA
AA Anahtar
10.47



Axial drilling - milling head collet chuck

Tetê de perçage - fraisage axiale mandrin pour pinces

Axial Tahrikli Takım Tutucu Pens Başlığı

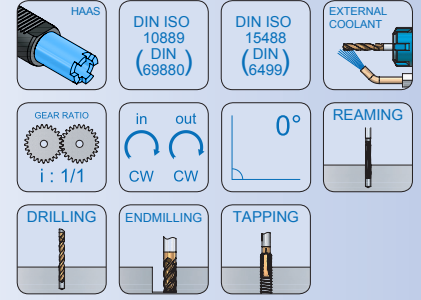
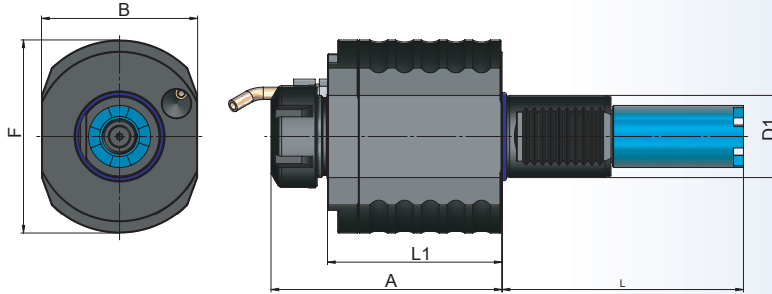

Bestell-Nr. Order Nr. Reference Sipariş Nr.	D1	Spannbereich Capacity Capacité Kapasite	A	L	L1	B	F	N.Max (1/min)	T.Max. (Nm)	Kg	Euro
SL2AX40E32112	40	ER32 (2 - 20)	112,5	104,85	76	76	94	6000	50		
SL2AX40E40126	40	ER40 (3 - 26)	126	104,85	76	76	94	6000	50		
SL4AX40E32112	40	ER32 (2 - 20)	112,5	117,55	76	76	94	6000	50	4,60	
SL4AX40E40126	40	ER40 (3 - 26)	126	117,55	76	76	94	6000	50		

Zubehör / Accessories / Accessoires / Yedekler



Spannzangen System ER
Collets System ER
Pincés de serrage System ER
Pens ER



Spannmutter ER
Clamping nuts ER
Écrou de serrage ER
Pens kapağı ER



Spannschlüssel ER
Wrench ER
Clé de serrage
Anahtar ER



AA Schlüssel
AA Wrench
Clé AA
AA Anahtar

Axial Fräskopf Fräsdornaufnahme

HAAS SL20 / SL40



Axial milling head chuck for cutter arbor

Tetê de fraisage axiale porte - fraise

Axial Tahrikli Takım Tutucu Alın Kamalı Malafa

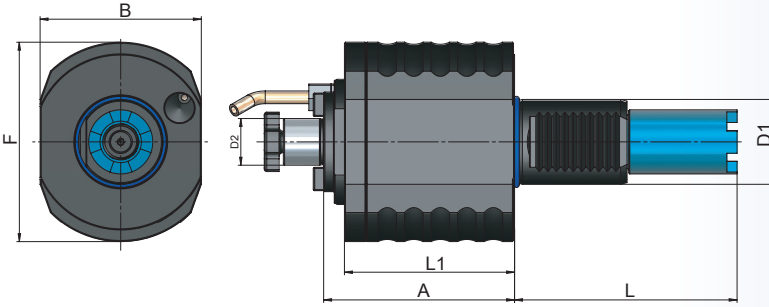
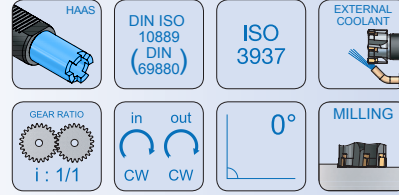

Bestell-Nr. Order Nr. Reference Sipariş Nr.	D1	D2	A	L	L1	B	F	N.Max (1/min)	T.Max. (Nm)	Kg	Euro
SL2AX40K16090	40	16	90	104,85	76	76	94	6000	50		
SL2AX40K22090	40	22	90	104,85	76	76	94	6000	50		
SL4AX40K16090	40	16	90	117,55	76	76	94	6000	50		
SL4AX40K22090	40	22	90	117,55	76	76	94	6000	50		

Zubehör / Accessories / Accessoires / Yedekler

DIN 6367



10.45

Fräseranzugsschrauben
Drawn in bolt
Vis de serrage
Alın sıkma civatası

DIN 6368



10.46

Mitnehmersteine
Drive keys
Entraîneur
Kama

DIN 6367



10.45

Spannschlüssel für Aufsteckdorne
Wrench
Clé de serrage
Alın civatası sıkma anahtarı



Radial drilling - milling head collet chuck

Tête de perçage - fraisage radiale mandrin pour pinces

Radial Tahrikli Takım Tutucu Pens Başlığı

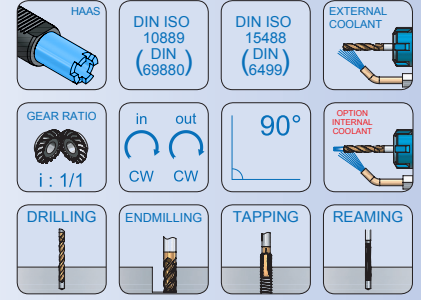
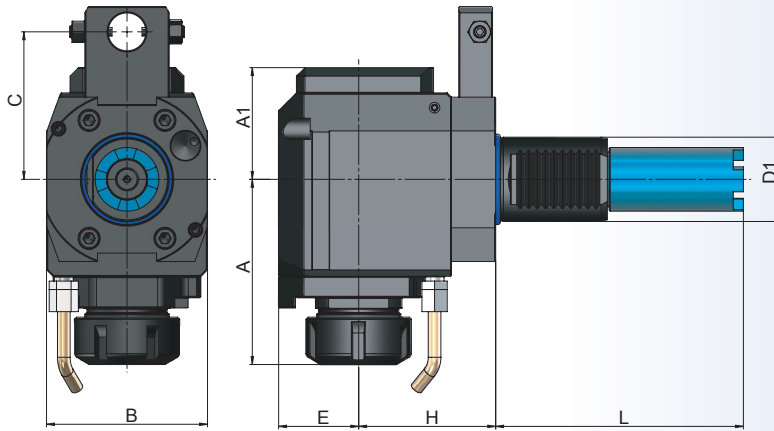

Bestell-Nr. Order Nr. Reference Sipariş Nr.	D1	Spannbereich Capacity Capacité Kapasite	A	A1	E	H	L	B	C	N.Max (1/min)	T.Max. (Nm)	Kg	Euro
SL2RA40E32A065C70	40	ER32 (2 - 20)	85	53	38	65	104,85	76	70	6000	50		
SL2RA40E32B065C70	40	ER32 (2 - 20)	85	53	38	65	104,85	76	70	6000	50		
SL2RA40E40A065C70	40	ER40 (3 - 26)	95	53	38	65	104,85	76	70	6000	50		
SL2RA4E40B065C70	40	ER40 (3 - 26)	95	53	38	65	104,85	76	70	6000	50		
SL4RA40E32A065C70	40	ER32 (2 - 20)	85	53	38	65	117,55	76	70	6000	50	5,85	
SL4RA40E32B065C70	40	ER32 (2 - 20)	85	53	38	65	117,55	76	70	6000	50	5,85	
SL4RA40E40A065C70	40	ER40 (3 - 26)	95	53	38	65	117,55	76	70	6000	50		
SL4RA4E40B065C70	40	ER40 (3 - 26)	95	53	38	65	117,55	76	70	6000	50		

Zubehör / Accessories / Accessoires / Yedekler



Spannzangen System ER
Collets System ER
Pincés de serrage System ER
Pens ER



Spannmutter ER
Clamping nuts ER
Écrou de serrage ER
Pens kapağı ER



Spann Schlüssel ER
Wrench ER
Clé de serrage
Anahtar ER



AA Schlüssel
AA Wrench
Clé AA
AA Anahtar



Radial milling head chuck for cutter arbor

Tête de fraisage radiale porte - fraise

Radial Tahrikli Takım Tutucu Alın Kamalı Malafa

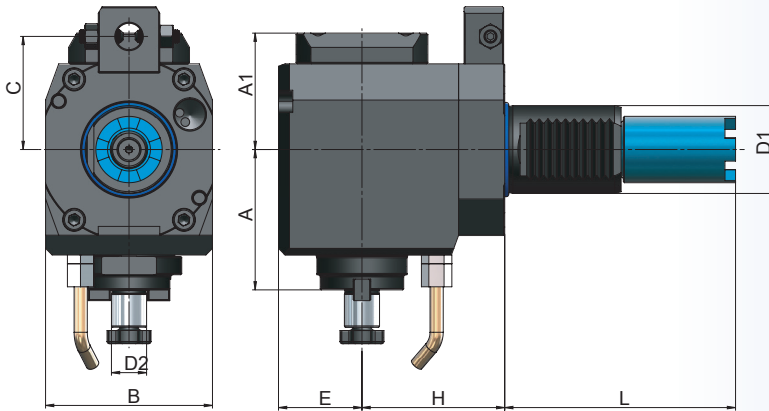
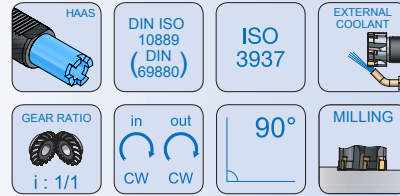

Bestell-Nr. Order Nr. Reference Sipariş Nr.	D1	D2	A	A1	E	H	L	B	C	N.Max (1/min)	T.Max. (Nm)	Kg	Euro
SL2RA40K16A065C70	40	16	64	53	38	65	104,85	76	70	6000	50		
SL2RA40K16B065C70	40	16	64	53	38	65	104,85	76	70	6000	50		
SL2RA40K22A065C70	40	22	64	53	38	65	104,85	76	70	6000	50		
SL2RA4K22B065C70	40	22	64	53	38	65	104,85	76	70	6000	50		
SL4RA40K16A065C70	40	16	64	53	38	65	117,55	76	70	6000	50		
SL4RA40K16B065C70	40	16	64	53	38	65	117,55	76	70	6000	50		
SL4RA40K22A065C70	40	22	64	53	38	65	117,55	76	70	6000	50		
SL4RA4K22B065C70	40	22	64	53	38	65	117,55	76	70	6000	50		

Zubehör / Accessories / Accessoires / Yedekler

DIN 6367



10.45

Fräseranzugsschrauben
Drawn in bolt
Vis de serrage
Alın sıkma civatası

DIN 6368



10.44

Mitnehmersteine
Drive keys
Entraîneur
Kama

DIN 6368



10.46

Spannschlüssel für Aufsteckdorne
Wrench
Clé de serrage
Alın civatası sıkma anahtarı



Radial drilling - milling head collet chuck - shifted

Tête de perçage - fraisage radiale mandrin pour pinces - décalé

Radial Tahrikli Takım Tutucu Pens Başlığı - Eksenden Kaçık

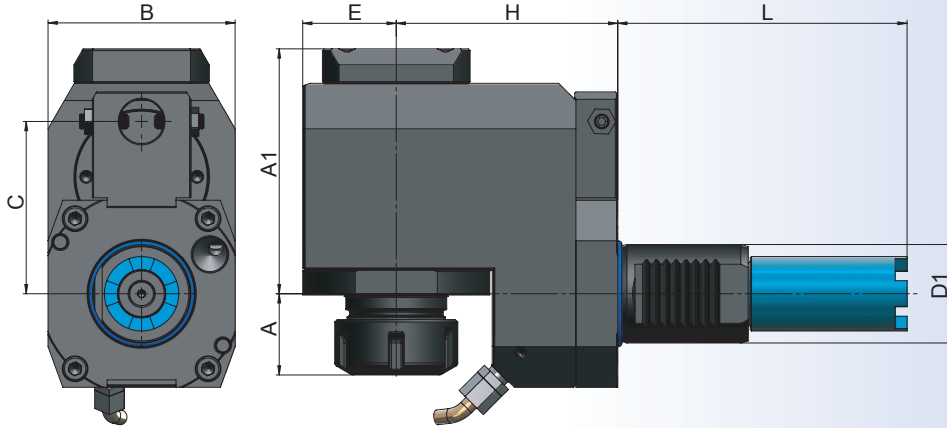

Bestell-Nr. Order Nr. Reference Sipariş Nr.	D1	Spannbereich Capacity Capacité Kapasite	A	A1	E	H	L	B	C	N.Max. (1/min)	T.Max. (Nm)	Kg	Euro
SL2RA40E32A065C70	40	ER32 (2 - 20)	35	99,5	38	90	104,85	64	70	5000	70		
SL2RA40E32B065C70	40	ER32 (2 - 20)	35	99,5	38	90	104,85	64	70	5000	70		
SL4RA40E32A065C70	40	ER32 (2 - 20)	35	99,5	38	90	117,55	76	70	5000	70		
SL4RA40E32B065C70	40	ER32 (2 - 20)	35	99,5	38	90	117,55	76	70	5000	70		

Zubehör / Accessories / Accessoires / Yedekler



Spannzangen System ER
Collets System ER
Pincés de serrage System ER
Pens ER



Spannmutter ER
Clamping nuts ER
Écrou de serrage ER
Pens kapağı ER



Spann Schlüssel ER
Wrench ER
Clé de serrage
Anahtar ER



AA Schlüssel
AA Wrench
Clé AA
AA Anahtar

Axial Bohr - und Fräskopf Spannzangenaufnahme

Nakamura



Axial drilling - milling head collet chuck

Tête de perçage - fraisage axiale mandrin pour pinces

Axial Tahrikli Takım Tutucu Pens Başlığı

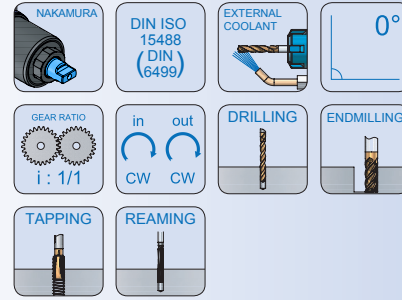
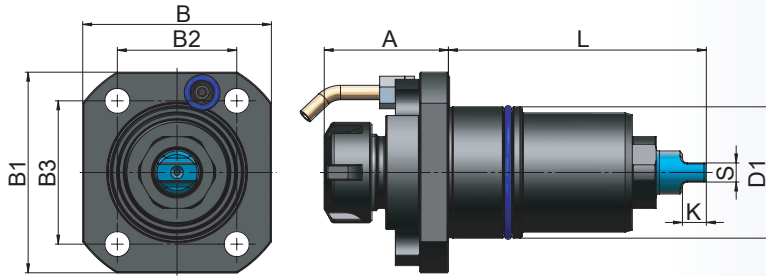

Bestell-Nr. Order Nr. Reference Sipariş Nr.	D1	Spannbereich Capacity Capacité Kapasite	A	L	B	B1	B2	B3	K	S	N.Max (1/min)	T.Max. (Nm)	Kg	Euro
new NKAX55E25051	55	ER25 (2 - 16)	51	108	79	82	50	60	10	8	6000	50	2,15	

Radial Bohr - und Fräskopf Spannzangenaufnahme

Nakamura

Radial drilling - milling head collet chuck

Tête de perçage - fraisage radiale mandrin pour pinces

Radial Tahrikli Takım Tutucu Pens Başlığı

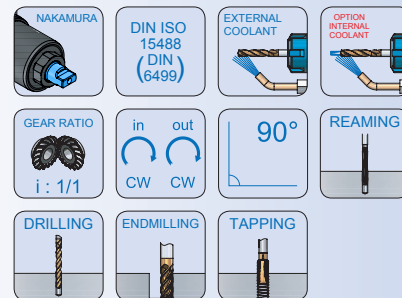
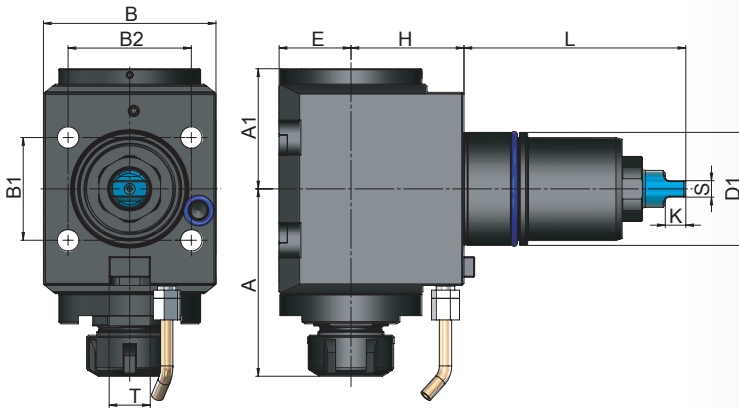

Bestell-Nr. Order Nr. Reference Sipariş Nr.	D1	Spannbereich Capacity Capacité Kapasite	A	A1	E	H	L	T	B	B1	B2	K	S	N.Max (1/min)	T.Max. (Nm)	Kg	Euro
new NKRA55E25AB055	55	ER25 (2 - 16)	90	58,5	35	55	108	20	84	65	80	10	8	6000	50	6,95	

Zubehör / Accessories / Accessoires / Yedekler

DIN ISO 15488
Spannzangen System ER
Collets System ER
Pincés de serrage System ER
Pens ER
10.11 - 10.18

DIN ISO 15488
Spannmutter ER
Clamping nuts ER
Écrou de serrage ER
Pens kapağı ER
10.25 - 10.26

Spannschlüssel ER
Wrench ER
Clé de serrage
Anahtar ER
10.48

AA Schlüssel
AA Wrench
Clé AA
AA Anahtar
10.47



Axial Bohr - und Fräskopf short Spannzangenaufnahme

Tsugami M06SY / M08SY

Axial drilling - milling head short collet chuck

Tetê de perçage - fraisage axiale short mandrin pour pinces

Axial Tahrikli Takım Tutucu Short Pens Başlığı

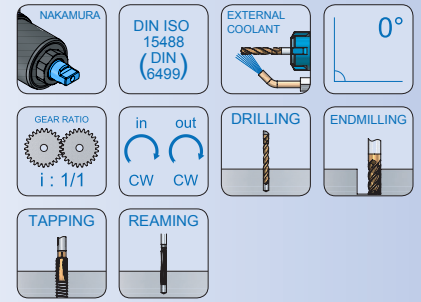
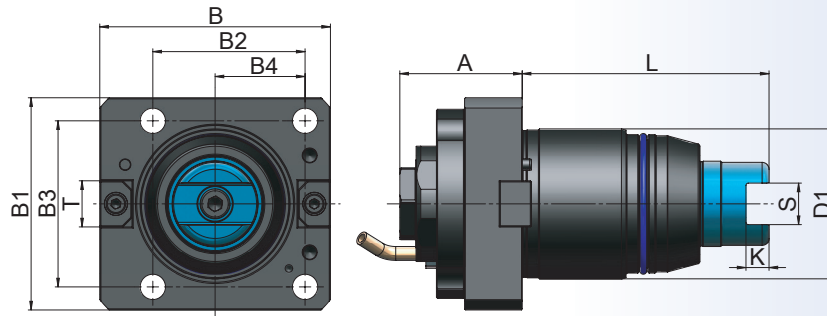

Bestell-Nr. Order Nr. Reference Sipariş Nr.	D1	Spannbereich Capacity Capacité Kapasite	A	L	T	B	B1	B2	B3	B4	K	S	N.Max (1/min)	T.Max. (Nm)	Kg	Euro
new TSUAX65E32S053	65	ER32 (2 - 20)	53	107	20	92	100	72	66	27	10	18	6000	50	3,80	

Radial Bohr - und Fräskopf short Spannzangenaufnahme

Tsugami M06SY / M08SY

Radial drilling - milling head short collet chuck

Tetê de perçage - fraisage radiale short mandrin pour pinces

Radial Tahrikli Takım Tutucu Short Pens Başlığı

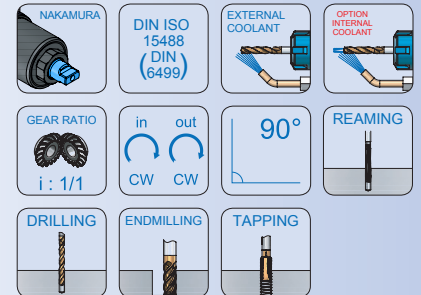
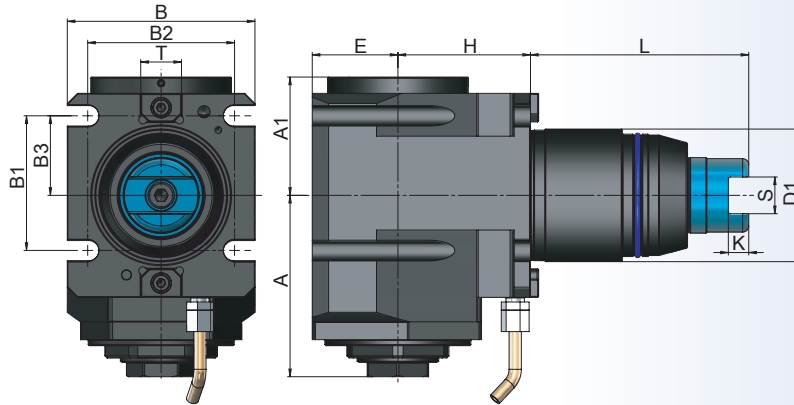

Bestell-Nr. Order Nr. Reference Sipariş Nr.	D1	Spannbereich Capacity Capacité Kapasite	A	A1	E	H	L	T	B	B1	B2	B3	K	S	N.Max (1/min)	T.Max. (Nm)	Kg	Euro
new TSURA65E32S065	65	ER32 (2 - 20)	89	58	42	65	107	20	92	72	66	27	10	18	6000	50	8,70	

Zubehör / Accessories / Accessoires / Yedekler



Spannzangen System ER
Collets System ER
Pincés de serrage System ER
Pens ER



Spannmutter ER
Clamping nuts ER
Écrou de serrage ER
Pens kapağı ER



Spannschlüssel ER
Wrench ER
Clé de serrage
Anahtar ER



AA Schlüssel
AA Wrench
Clé AA
AA Anahtar



Radial drilling - milling head collet chuck - shifted

Tetê de perçage - fraissage radiale mandrin pour pinces - décalé

Radial Tahrikli Takım Tutucu Pens Başlığı - Eksenden Kaçık

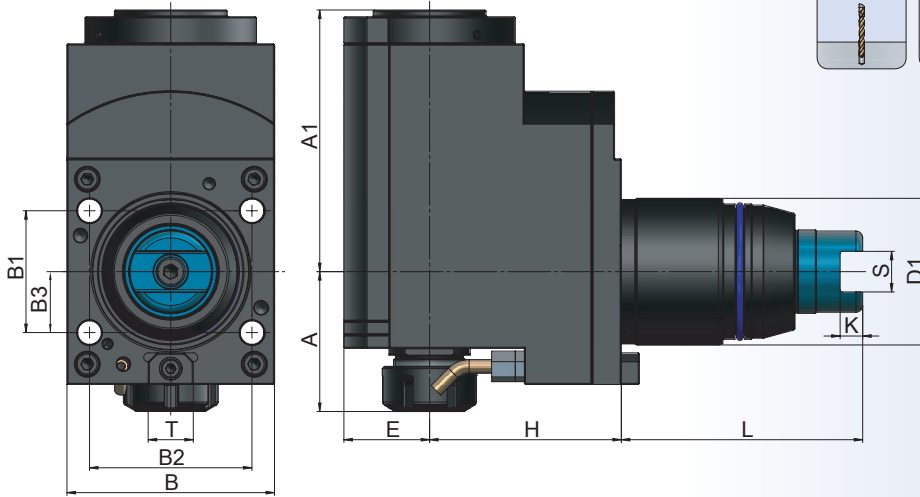
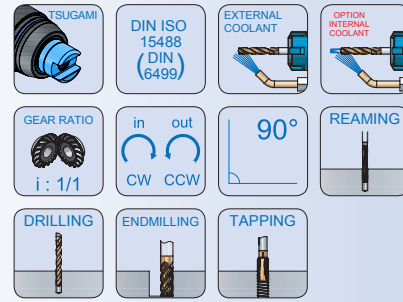

Bestell-Nr. Order Nr. Reference Sipariş Nr.	D1	Spannbereich Capacity Capacité Kapasite	A	A1	E	H	L	T	B	B1	B2	B3	K	S	N.Max (1/min)	T.Max. (Nm)	Kg	Euro
new TSURK65E25B085	65	ER25 (2 - 16)	64	116	38	85	107	20	92	72	66	27	10	18	6000	50		

Zubehör / Accessories / Accessoires / Yedekler

DIN ISO 15488

 Spannzangen System ER
 Collets System ER
 Pincés de serrage System ER
 Pens ER
 10.11 - 10.18

DIN ISO 15488

 Spannmutter ER
 Clamping nuts ER
 Écrou de serrage ER
 Pens kapağı ER
 10.24

 Spannschlüssel ER
 Wrench ER
 Clé de serrage
 Anahtar ER
 10.48

 AA Schlüssel
 AA Wrench
 Clé AA
 AA Anahtar
 10.47

