

PRODUCT NEWS

PN-E-015

SERIES EXPANSION

NEW

For high efficient roughing

SKS-G II

for high feed machining with 4corners.

SKG/MSGtype

- Face mill type: $\varnothing 50 \sim \varnothing 160$
- Modular head type: $\varnothing 25 \sim \varnothing 42$



G-Body



"SKS-G II" SKG / MSG type, innovative high feed cutter achieved extremely excellent chip removal rate!

DIJET GmbH • www.dijet.de

Feature of product

“SKS-G II” SKG / MSG type, innovative high feed cutter achieved extremely excellent chip removal rate!

Features 1

Applicable to deep cutting of mold material or high feed machine aircraft parts that made of titanium alloy & stainless steel.



Features 2

Adopted economical 4 corners positive insert, achieved stable high feed machining.

Features 3

Large Δp machining is possible.
(Max. $\Delta p=1.5\text{mm}$ in case of using insert SPNW10-type &
Max. $\Delta p=2.5\text{mm}$ in case of using SPNW14-type insert)



Features 4

Two types inserts with chipbreaker are available for hard-to-cut material or mold material).

Due to low cutting force geometry insert, stable machining in mold material is possible even in case of using low power machine or long overhung tool.



SM breaker insert for hard-to-cut material



PM breaker insert for mold material



Features 5

3 insert grades "JC8118", "JC8050" & "JC7550" can be widely applied from general & mold steel to hard-to-cut materials such as high hardened die steel, titanium alloy & stainless steel.

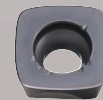

JC8118

For mold steel more than 38HRC & high hardened die steel less than 50HRC.

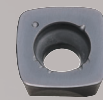

JC8050

For general & mold steel less than 36HRC.



JC7550

For titanium alloy & stainless steel.

Application

ISO	P					M					K				S				H		
	P01	P10	P20	P30	P40	M01	M10	M20	M30	M40	K01	K10	K20	K30	S01	S10	S20	S30	H01	H10	H20
Applicable range	JC8118										JC8118								JC8118		
	JC8050																				
						JC7550									JC7550						

Features 6

Large chip pocket achieved excellent chip removal.

Cutting performance

Cutting force comparison

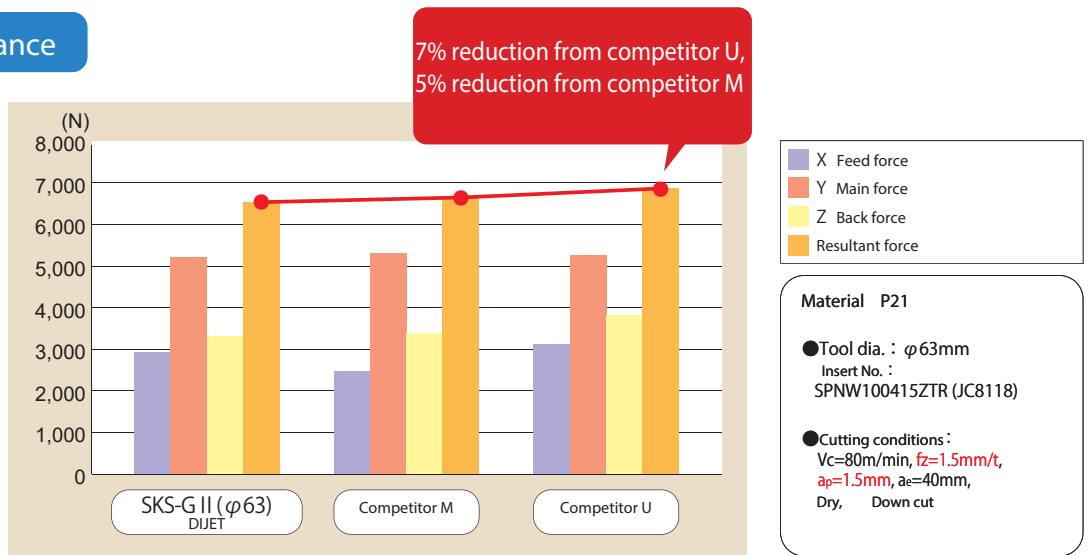

Tool life comparison

① Insert without chipbreaker

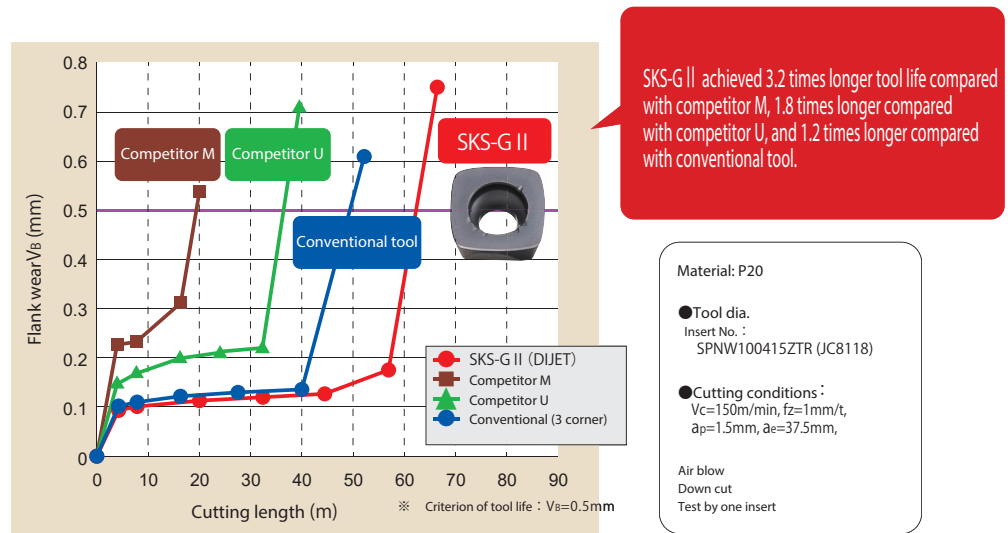

② Insert with chipbreaker

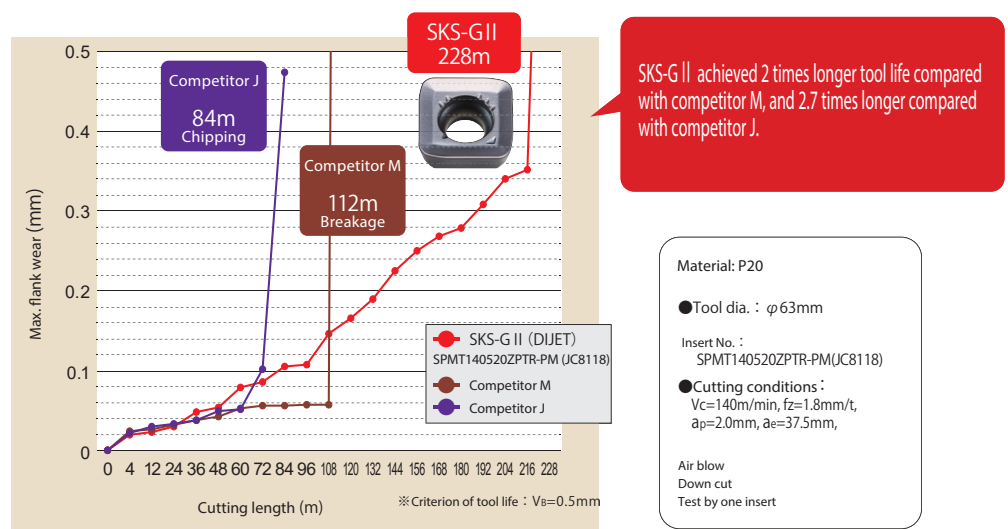

Line up

● Facemill type (Insert 10-type)

G-Body



● Through coolant hole

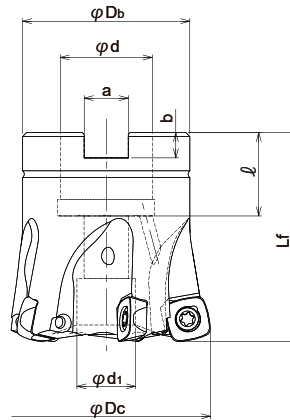

● Body

Type	Cat. No.	Stock	No. of inserts	Dimensions (mm)								Set bolt	Weight (kg)	Applicable inserts	
				φDc	Lf	φDb	φd	$\varphi d1$	a	b	l				
Metric Bore	SKG-4050R-10-22	●	4	50	50	40	22	14	10.4	6.3	20	M10×1.5×35★	Head cap screw (Slim head)	0.3	 SPNW10** SPET10** SPMT10**
	SKG-5050R-10-22	●	5	50	50	40	22	14	10.4	6.3	20	M10×1.5×35★	0.3		
	SKG-5052R-10-22	●	5	52	50	40	22	16.6	10.4	6.3	20	M10	0.3		
	SKG-5063R-10-22	□	5	63	50	48	22	17	10.4	6.3	20	M10	Head cap screw (JIS standard)	0.5	 Clamp screw TSW-3509H
	SKG-5063R-10-27	□	5	63	50	48	27	20	12.4	7	22	M12×1.75×30★		0.5	
	SKG-6063R-10-22	●	6	63	50	48	22	17	10.4	6.3	20	M10		0.5	
	SKG-6063R-10-27	●	6	63	50	48	27	20	12.4	7	22	M12×1.75×30★		0.5	
	SKG-6066R-10-27	●	6	66	50	50	27	20	12.4	7	22	M12×1.75×30★		0.6	
	SKG-6080R-10-27	●	6	80	50	60	27	20	12.4	7	22	M12×1.75×30★		0.9	

- : Standard stock items.
- : Stock in Japan. (7-10 days delivery upon ordering)

- Note) 1. All cutters are supplied without inserts.
 2. ★ mark shows: these cutter body are equipped with the set bolt because of the specified bolt size. Except for these cutter body, please use the set bolt equipped with arbor.
 3. Set bolt (M10×1.5×35) is slim head type with φ13 head dia.
 4. All cutters are supplied without wrench & MOLY since February 2019 for our stock production.

Wrench



A-15T

Clamp screw	Recommended torque (N·m)
TSW-3509H	3.0

G-Body

Adopted GN surface-hardening treatment on thermal resistant high strength steel gives high hardness over 65HRC and secure insert pocket and holder against thermal deformation, improved body durability and tool life by 30% or more. Make it difficult to be damaged even under severe cutting conditions. Also rust-proof and anti-welding effect is much improved.

Line up

MSG-10
Modular head type (Insert 10-type)



● Through coolant hole

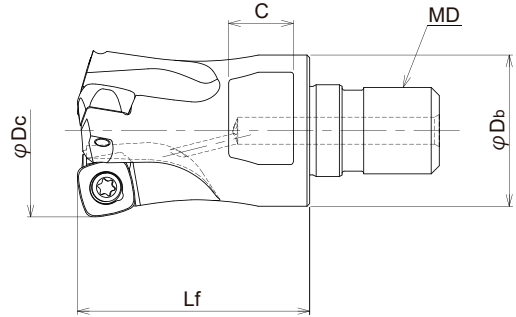
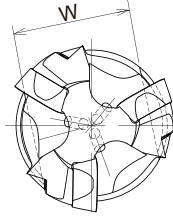

Body

Cat. No.	Stock	No. of inserts	Dimensions (mm)					Applicable inserts	Parts	
			φDc	Lf	φDb	MD	C		W	Clamp screw
MSG-2025-10-M12	●	2	25	35	23	M12	11	SPNW10** SPET10** SPMT10**	TSW-3509H	A-15
MSG-3032-10-M16	●	3	32	43	28	M16	12			
NEW MSG-3035-10-M16	□	3	35	43	30	M16	14			
MSG-4040-10-M16	●	4	40	43	32	M16	14			
MSG-4042-10-M16	●	4	42	43	32	M16	14			

●: Standard stock items
□: Stock in Japan (7-10 days delivery upon ordering)

- Note) 1. All cutters are supplied without inserts.
2. Please see page 17 for recommended tightening torque.
3. In case of using MSG-4040/4042-10-M16, recommend combining with MSN carbide shank straight arbor type.
4. All cutters are supplied without wrench & MOLY since February 2019 for our stock production.

Clamp screw	Recommended torque (N·m)
TSW-3509H	3.0

Insert 10-type



Fig.1 SPNW100415ZTR



Fig.2 SPET100415ZPER-SM



Fig.3 SPMT100415ZPER-SM



Fig.4 SPMT100415ZPTR-PM

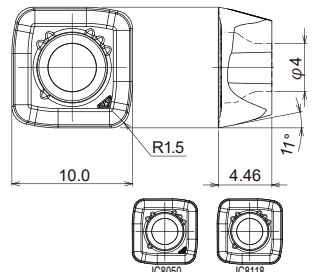
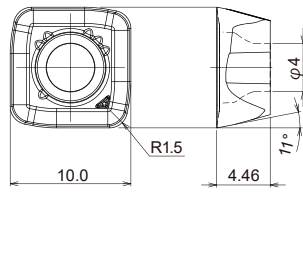
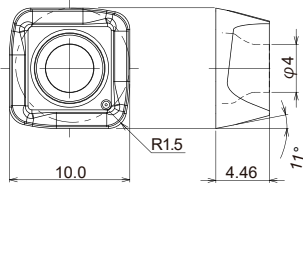
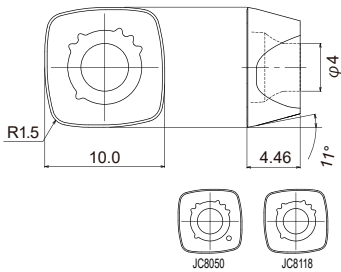

Cat. No.	Tolerance	PVD Coated			Fig.
		JC7550	JC8050	JC8118	
SPNW100415ZTR	N		●	●	1
SPET100415ZPER-SM	E	●			2
SPMT100415ZPER-SM	M	●			3
NEW SPMT100415ZPTR-PM	M		●	●	4

●: Standard stock items
10 inserts per case.

MSN Carbide shank arbor

End mill shank type

- Through coolant hole
- For high productivity

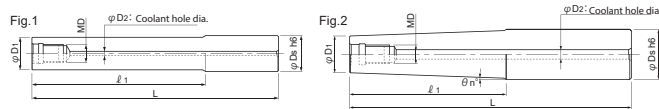

Cat. No.	Stock	Dimensions (mm)						Weight (kg)	Fig.	
		φD_s	l_1	L	φD_1	θn°	MD			
MSN-M12-25-S25C	●	25	25	90	24	-	M12	6	0.53	1
MSN-M12-55-S25C	●	25	55	120	24	-			0.72	1
MSN-M12-100T-S32C	□	32	100	180	23.5	2°			1.61	2
MSN-M12-105-S25C	●	25	105	170	24	-			1.03	1
MSN-M12-135-S25C	●	25	135	215	24	-			1.30	1
MSN-M12-155-S25C	●	25	155	220	24	-			1.34	1
MSN-M12-200-S25C	●	25	200	265	24	-			1.58	1
MSN-M16-25-S32C	●	32	25	90	29	-			M16	8
MSN-M16-55-S32C	●	32	55	120	29	-	1.13	1		
MSN-M16-77-S32C	●	32	77	157	29	-	1.47	1		
MSN-M16-97-S32C	●	32	97	177	29	-	1.64	1		
MSN-M16-105-S32C	●	32	105	170	29	-	1.59	1		
MSN-M16-117T-S32C	□	32	117	197	29	0°38'	1.88	2		
MSN-M16-127-S32C	●	32	127	207	29	-	1.89	1		
MSN-M16-127T-S32C	□	32	127	207	29	0°30'	2.23	2		
MSN-M16-155-S32C	●	32	155	220	29	-	2.04	1		
MSN-M16-177-S32C	●	32	177	257	29	-	2.32	1		
MSN-M16-177T-S32C	●	32	177	257	29	0°23'	2.78	2		
MSN-M16-195-S32C	●	32	195	260	29	-	2.40	1		
MSN-M16-197T-S32C	□	32	197	277	29	0°23'	3.00	2		
MSN-M16-225-S32C	●	32	225	290	29	-	2.57	1		
MSN-M16-245-S32C	●	32	245	310	29	-	2.74	1		
MSN-M16-295-S32C	●	32	295	360	29	-	3.17	1		

- : Standard stock items
 - : Stock in Japan (7-10 days delivery upon ordering)
- Note) Please see page 17 for recommended tightening torque.



Straight arbor type

- Through coolant hole
- For high productivity

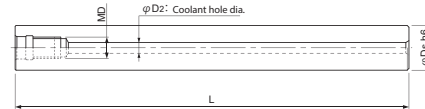

Cat. No.	Stock	Dimensions (mm)				Weight (kg)
		φD_s	L	MD	φD_2	
MSN-M12-185S-S23C	●	23	185	M12	6	0.98
MSN-M12-265S-S23C	●		265			1.42
MSN-M12-185S-S24C	●	24	185	M12	6	1.07
MSN-M12-265S-S24C	●		265			1.54
MSN-M12-145S-S25C	●	25	145	M12	6	0.91
MSN-M12-215S-S25C	●		215			1.36
MSN-M12-285S-S25C	●		285			1.80
MSN-M16-160S-S28C	●	28	160	M16	8	1.22
MSN-M16-230S-S28C	●		230			1.77
MSN-M16-310S-S28C	●		310			2.41
MSN-M16-157S-S32C	●	32	157	M16	8	1.61
MSN-M16-217S-S32C	●		217			2.22
MSN-M16-287S-S32C	●		287			2.94
MSN-M16-357S-S32C	●		357			3.66

- : Standard stock items
- Note) Please see page 17 for recommended tightening torque.



MGN G-Body steel shank holder

- Adopted ultra-rigid and improved body durability "G-Body".
- Short type
- Cost-effective and high strength steel shank holder.

End mill shank type

- Through coolant hole

G-Body

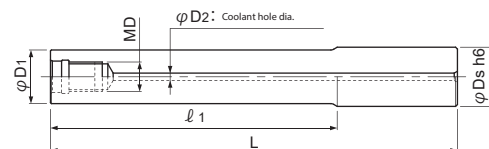
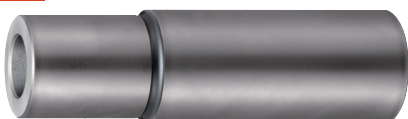

Cat. No.	Stock	Dimensions (mm)						Weight (kg)	
		φD_s	l_1	L	φD_1	θn°	MD		
MGN-M12-35-S25	□	25	35	105	24	-	M12	4	0.36
MGN-M12-85-S25	□	25	85	165	24	-	M12	4	0.57
MGN-M16-37-S32	□	32	37	107	29	-	M16	6	0.56
MGN-M16-77-S32	□	32	77	157	29	-	M16	6	0.83

□: Stock in Japan (7-10 days delivery upon ordering)

- Note) 1. In case of using modular head combined with MGN steel shank holder, apply the recommended cutting conditions sheet (see page 13).
2. Please see page 17 for recommended tightening torque.

Line up

● SKG-14 Facemill type (Insert 14-type)



● fig.1
Through coolant hole
($\varphi D_c \leq \varphi 100$)

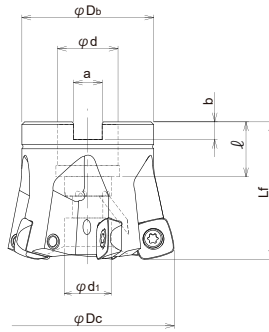

● fig.2
Without coolant hole
($\varphi D_c \geq \varphi 125$)

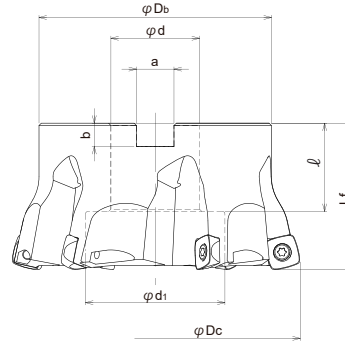

● Body

Type	Cat. No.	Stock	No. of inserts	Dimensions (mm)								Set bolt	Weight (kg)	Fig.	Applicable inserts	
				φD_c	L_f	φD_b	φd	φd_1	a	b	ℓ					
Metric Bore	SKG-4050R-14-22	●	4	50	50	40	22	9.6	10.4	6.3	19.05	M10×1.5×35★	Head cap screw (Slim head)	0.3	1	SPNW14** SPMT14**
	SKG-4052R-14-22	●	4	52	50	42	22	17	10.4	6.3	19.05	M10×1.5×35★	Head cap screw (Slim head)	0.3	1	
	SKG-4063R-14-22	●	4	63	50	48	22	17	10.4	6.3	20	M10	Head cap screw (JIS Standard)	0.5	1	
	SKG-4063R-14-27	●	4	63	50	48	27	20	12.4	7	22	M12×1.75×35★		0.5	1	
	SKG-5066R-14-27	●	5	66	50	50	27	20	12.4	7	22	M12×1.75×35★		0.5	1	
	SKG-5080R-14-27	●	5	80	50	60	27	37	12.4	7	22	M12×1.75×35★		0.8	1	
	SKG-6100R-14-32	●	6	100	63	70	32	45	14.4	8	25	M16		1.6	1	

●: Standard stock items

- Note) 1. All cutters are supplied without inserts.
- 2. ★ mark shows: these cutter body are equipped with the set bolt because of the specified bolt size. Except for these cutter body, please use the set bolt equipped with arbor.
- 3. Set bolt (M10×1.5×35) is slim head type with $\varphi 13$ head dia.
- 4. All cutters are supplied without wrench & MOLY since February 2019 for our stock production.

Parts
Clamp screw

CSW-513H

Wrench

A-20

Clamp screw	Recommended torque (N·m)
CSW-513H	5.5

● Insert 14-type

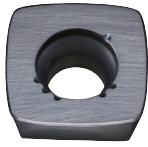

Fig.1 SPNW140515ZTR



Fig.2 SPMT140520ZPER-SM



Fig.3 SPMT140520ZPTR-PM

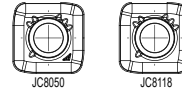
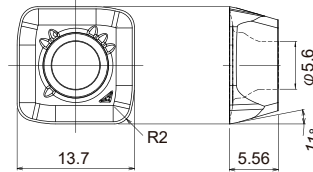
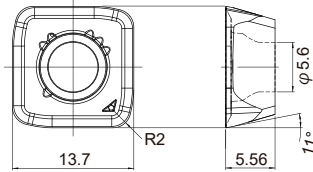
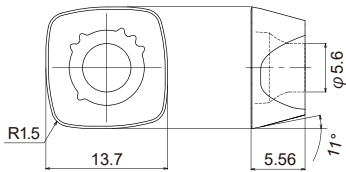

Cat. No.	Tolerance	PVD Coated			Fig.
		JC7550	JC8050	JC8118	
SPNW140515ZTR	N		●	●	1
NEW SPMT140520ZPER-SM	M	●			2
NEW SPMT140520ZPTR-PM	M		●	●	3

● : Standard stock items
10 inserts per case.

Cutting data

① High feed machining on mold steel (Insert 10-type)

Overhung length : 130mm
Contouring & slotting

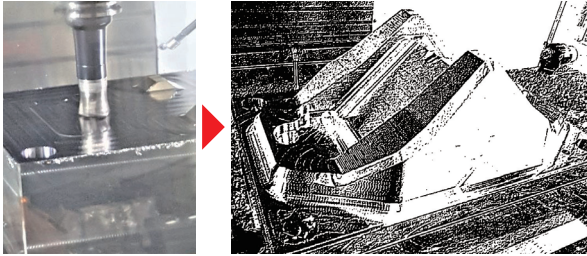

Result
Achieved high metal removal rate ($Q=126\text{cm}^3/\text{min}$) by 1.8 times compared with competitor's tool. And finished all the job with one corner, no wear or breakage, with a contact time of 3h 40min.

Work	Part name	Plastic mold	
	Material	Mold steel (1.2311)	
	Hardness	32-34HRC	
Tool	Tool No.	MSG-3032-10-M16	
	Insert No.	SPNW100415ZTR (JC8118)	
Cutting conditions	Cutting speed	n	2,000 (min^{-1})
		V_c	201 (m/min)
	Feed speed	V_f	6,300 (mm/min)
		f_z	1.1 (mm/t)
	a_p		0.8 (mm)
	a_e		25 (mm)
	Coolant		Air blow
	Machine		Vertical MC

② High feed machining on mold steel (Insert 14-type)

Overhung length : 220mm

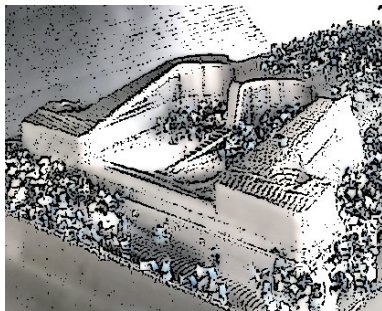

Result
Achieved high metal removal rate ($Q=330\text{cm}^3/\text{min}$) by 1.2 times compared with competitor's tool. And able to machine about 3 hours per 1 corner.

Work	Part name	Plastic mold	
	Material	Mold steel (1.2738)	
	Hardness	36HRC	
Tool	Tool No.	SKG-6080R-14-27	
	Insert No.	SPNW140515ZTR (JC8118)	
Cutting conditions	Cutting speed	n	560 (min^{-1})
		V_c	140 (m/min)
	Feed speed	V_f	4,000 (mm/min)
		f_z	1.2 (mm/t)
	a_p		1.5 (mm)
	a_e		55 (mm)
	Coolant		Air blow
	Machine		Vertical MC

③ High efficient machining on Ti-alloy (Insert 10-type)

Overhung length : 110mm

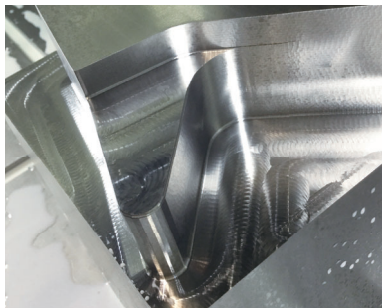

Result
Machining test piece shaped like aircraft parts. No chatter & smooth cutting, and achieved good chip removal.

Work	Part name	Test piece	
	Material	Ti-6Al-4V	
	Hardness	50HRC	
Tool	Tool No.	MSG-3032-10-M16	
	Insert No.	SPET100415ZPER-SM (JC7550)	
Cutting conditions	Cutting speed	n	597 (min^{-1})
		V_c	60 (m/min)
	Feed speed	V_f	1,075 (mm/min)
		f_z	0.6 (mm/t)
	a_p		1 (mm)
	a_e		12.8 (mm)
	Coolant		Wet (internal)
	Machine		Vertical MC

Definition of corner shape for programming

■ SPNW100415ZTR type inserts

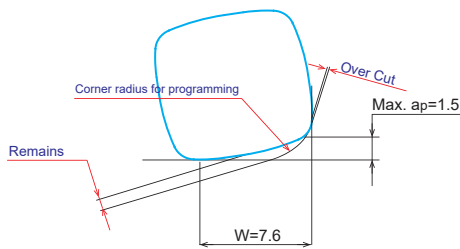

Corner R for programming	Over cut	Remains
R2.5	0	0.99
R3.0 (Standard)	0	0.84
R3.5	0.09	0.71
R4.0	0.23	0.59

■ SPE(M)T100415ZPER-SM type or SPMT100415ZPTR-PM type inserts

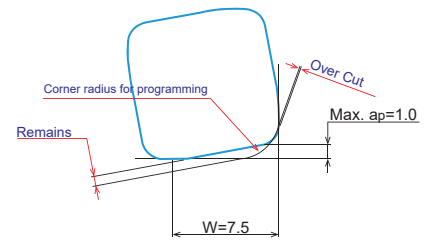

Corner R for programming	Over cut	Remains
R2.5 (Standard)	0	0.77
R3.0	0.09	0.68
R3.5	0.25	0.60
R4.0	0.43	0.52

■ SPNW140515ZTR type inserts

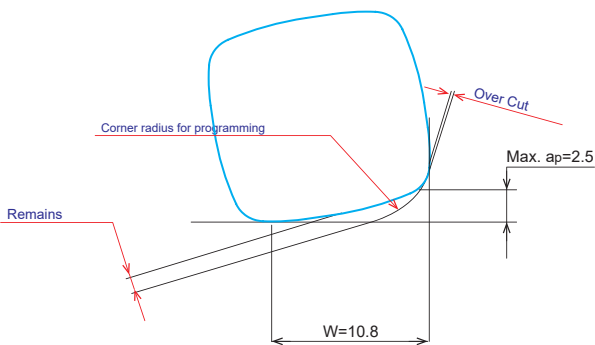

Corner R for programming	Over cut	Remains
R3.5	0	1.60
R4.0 (Standard)	0	1.46
R4.5	0.06	1.32
R5.0	0.17	1.19

■ SPMT140520ZPER-SM type or SPMT140520ZPTR-PM type inserts

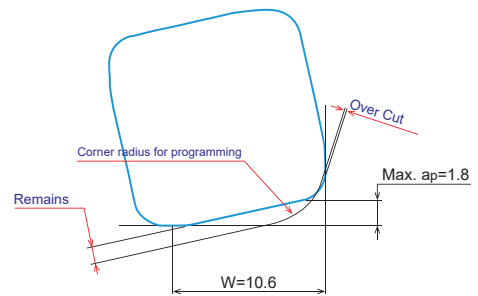

Corner R for programming	Over cut	Remains
R3.5 (Standard)	0	1.35
R4.0	0.02	1.25
R4.5	0.14	1.12
R5.0	0.29	1.05

Attention for profile milling

Ramping

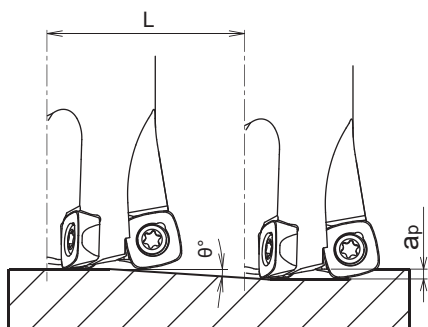

Helical interpolation

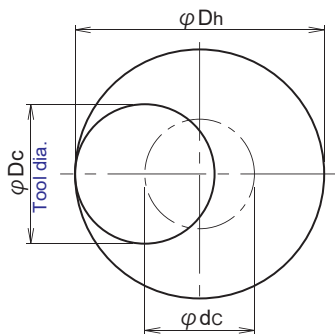

● Calculation of tool pass dia.

$$\varphi dc = \varphi Dh - \varphi Dc$$

Tool pass dia. Bore dia. Tool dia.

● Depth of cut per one circuit should not exceed max. depth of cut ap.

● Down cutting is recommended, so tool pass rotation should be counterclockwise.

◎ In case of ramping and helical interpolation, apply 70% or less feed speed from standard cutting condition table.

■ SPNW100415ZTR or SPNW140515ZTR type inserts

Cat. No.	Tool dia. (mm)	Eff. Cutting dia. (mm)	Max. depth of cut (mm)	Ramping		Helical interpolation	
				Max. ramping angle θ°	Total cutting length at Max. ap	Min. bore dia. Dh min (mm)	Max. bore dia. Dh max (mm)
MSG-2025-10	25	9.8	1.5	1°	85.9	36	48
MSG-3032-10	32	16.8	1.5	1°	85.9	50	62
MSG-3035-10	35	19.8	1.5	1°	85.9	56	70
MSG-4040-10	40	24.8	1.5	1°	85.9	66	78
MSG-4042-10	42	26.8	1.5	1°	85.9	70	82
SKG-*050R-10	50	34.8	1.5	1°	85.9	86	98
SKG-5052R-10	52	36.8	1.5	1°	85.9	90	102
SKG-*063R-10	63	47.8	1.5	0°45'	114.6	112	124
SKG-6066R-10	66	50.8	1.5	0°45'	114.6	118	130
SKG-6080R-10	80	64.8	1.5	0°30'	171.9	146	158
SKG-4050R-14	50	28.4	2.5	1°	143.2	80	98
SKG-4052R-14	52	30.4	2.5	1°	143.2	84	102
SKG-*063R-14	63	41.4	2.5	0°45'	191	106	124
SKG-5066R-14	66	44.4	2.5	0°45'	191	112	130
SKG-5080R-14	80	58.4	2.5	0°30'	286.5	140	158
SKG-6100R-14	100	78.4	2.5	0°20'	430	180	198
SKG-6125R-14	125	103.4	2.5	0°20'	430	230	248
SKG-7160R-14	160	138.4	2.5	0°15'	573	300	318

■ SPE (M) T100415ZPER-SM type or SPMT100415ZPTR-PM type

■ SPMT140520ZPER-SM type or SPMT140520ZPTR-PM type

Cat. No.	Tool dia. (mm)	Eff. Cutting dia. (mm)	Max. depth of cut (mm)	Ramping		Helical interpolation	
				Max. ramping angle θ°	Total cutting length at Max. ap	Min. bore dia. Dh min (mm)	Max. bore dia. Dh max (mm)
MSG-2025-10	25	10	1.0	1°	57.3	36	48
MSG-3032-10	32	17	1.0	1°	57.3	50	62
MSG-3035-10	35	20	1.0	1°	57.3	56	70
MSG-4040-10	40	25	1.0	1°	57.3	66	78
MSG-4042-10	42	27	1.0	1°	57.3	70	82
SKG-*050R-10	50	35	1.0	1°	57.3	86	98
SKG-5052R-10	52	37	1.0	1°	57.3	90	102
SKG-*063R-10	63	48	1.0	0°45'	76.4	112	124
SKG-6066R-10	66	51	1.0	0°45'	76.4	118	130
SKG-6080R-10	80	65	1.0	0°30'	114.6	146	158
SKG-4050R-14	50	28.8	1.8	1°	103.1	80	98
SKG-4052R-14	52	30.8	1.8	1°	103.1	84	102
SKG-*063R-14	63	41.8	1.8	0°45'	137.5	106	124
SKG-5066R-14	66	44.8	1.8	0°45'	137.5	112	130
SKG-5080R-14	80	58.8	1.8	0°30'	206.3	140	158
SKG-6100R-14	100	78.8	1.8	0°20'	206.3	180	198
SKG-6125R-14	125	123.8	1.8	0°20'	206.3	230	248
SKG-7160R-14	160	138.8	1.8	0°15'	412.5	300	318

Recommended cutting conditions

MSG-10 Modular head type (Insert 10-type)

Work materials	Grades	Tool dia. (mm)														
		25					32/35					40/42				
		No. of teeth 2N					No. of teeth 3N					No. of teeth 4N				
		l (mm)	a_p (mm)	a_e (mm)	n (min ⁻¹)	V_f (mm/min)	l (mm)	a_p (mm)	a_e (mm)	n (min ⁻¹)	V_f (mm/min)	l (mm)	a_p (mm)	a_e (mm)	n (min ⁻¹)	V_f (mm/min)
Carbon steel (C50,C55) Below 250HB	JC8050 (JC8118) SPNW type SPMT-PM type	~75	1	~9	2,290	6,870	~100	1	~14	1,640	7,380	~100	1	~24	1,430	8,580
		125	0.8	~9	2,290	6,870	150	0.8	~14	1,640	7,380	150	0.8	~24	1,430	8,580
		175	0.6	~9	2,290	6,410	210	0.6	~14	1,640	6,890	210	0.6	~24	1,430	8,010
Die steel (1.2344,1.2379) Below 255HB	JC8050 (JC8118) SPNW type SPMT-PM type	~75	1	~9	1,910	5,730	~100	1	~14	1,360	6,120	~100	1	~24	1,190	7,140
		125	0.8	~9	1,910	5,730	150	0.8	~14	1,360	6,120	150	0.8	~24	1,190	7,140
		175	0.6	~9	1,910	5,350	210	0.6	~14	1,360	5,710	210	0.6	~24	1,190	6,660
Mold steel (1.2311,P20) 30-36HRC	JC8050 (JC8118) SPNW type SPMT-PM type	~75	1	~9	1,910	5,730	~100	1	~14	1,360	6,120	~100	1	~24	1,190	7,140
		125	0.8	~9	1,910	5,730	150	0.8	~14	1,360	6,120	150	0.8	~24	1,190	7,140
		175	0.6	~9	1,910	5,350	210	0.6	~14	1,360	5,710	210	0.6	~24	1,190	6,660
Mold steel (1.2311,P21) 38-43HRC	JC8118 (JC8050) SPNW type SPMT-PM type	~75	1	~9	1,400	3,640	~100	1	~14	1,000	3,900	~100	1	~24	880	4,580
		125	0.8	~9	1,400	3,640	150	0.8	~14	1,000	3,900	150	0.8	~24	880	4,580
		175	0.6	~9	1,400	3,360	210	0.6	~14	1,000	3,600	210	0.6	~24	880	4,220
Hardened die steel (1.2344, 1.2379) 42-52HRC	JC8118 SPNW type	~75	0.6	~9	1,270	3,050	~100	0.6	~14	910	3,280	~100	0.6	~24	800	3,840
		125	0.4	~9	1,270	3,050	150	0.4	~14	910	3,280	150	0.4	~24	800	3,840
		175	0.3	~9	1,270	2,540	210	0.3	~14	910	2,730	210	0.3	~24	800	3,200
Grey & Nodular cast iron (GG, GGG) Below 300HB	JC8118 SPNW type SPMT-PM type	~75	1.2★	~9	2,290	6,870	~100	1.2★	~14	1,640	7,380	~100	1.2★	~24	1,430	8,580
		125	1	~9	2,290	6,870	150	1	~14	1,640	7,380	150	1	~24	1,430	8,580
		175	0.8	~9	2,290	6,870	210	0.8	~14	1,640	7,380	210	0.8	~24	1,430	8,580
Stainless steel Below 250HB	JC7550 SPMT-SM type SPET-SM type	~75	1	~9	1,910	3,820	~100	1	~14	1,360	4,080	~100	1	~24	1,190	4,760
		125	0.8	~9	1,910	3,820	150	0.8	~14	1,360	4,080	150	0.8	~24	1,190	4,760
		175	0.6	~9	1,660	2,990	210	0.6	~14	1,180	3,190	210	0.6	~24	1,030	3,710
Titanium alloy (Ti-6Al-4V)	JC7550 SPMT-SM type SPET-SM type	~75	1	~9	760	910	~100	1	~14	550	990	~100	1	~24	480	1,150
		125	0.8	~9	760	910	150	0.8	~14	550	990	150	0.8	~24	480	1,150
		175	0.6	~9	760	760	210	0.6	~14	550	830	210	0.6	~24	480	960

l : Overhung length a_p : Axial depth of cut a_e : Radial depth of cut n : Spindle speed V_f : Feed speed

Note:

*1. The figure to be adjusted according to the machine rigidity or work rigidity.

*2. In case of chatter occurring, recommend to reduce the depth of cut a_p or Spindle speed and keep feed per tooth.

*3. If machine does not have enough power, recommend to reduce the depth of cut a_p or Spindle speed and

Feed speed.

*4. Use air blow.

★ : Reduce the depth of cut a_p to below 1.0mm in case of using SPMT / SPET type insert.

Recommended cutting conditions

SKG-10 Facemill type (Insert 10-type)

Work materials	Grades	Tool dia. (mm)														
		50					50/52					63				
		No. of teeth 4N					No. of teeth 5N					No. of teeth 5N				
		l (mm)	a_p (mm)	a_e (mm)	n (min ⁻¹)	V_f (mm/min)	l (mm)	a_p (mm)	a_e (mm)	n (min ⁻¹)	V_f (mm/min)	l (mm)	a_p (mm)	a_e (mm)	n (min ⁻¹)	V_f (mm/min)
Carbon steel (C50,C55) Below 250HB	JC8050 (JC8118) SPNW type SPMT-PM type	~150	1.5★	~32	1,020	7,340	~150	1.5★	~32	1,020	9,180	~150	1.5★	~44	810	7,290
		200	1.2★	~32	1,020	7,340	200	1.2★	~32	1,020	9,180	200	1.5★	~44	810	7,290
		250	0.8	~32	890	5,340	250	0.8	~32	890	6,680	250	1.2★	~44	710	5,330
		300	0.6	~32	830	4,980	300	0.6	~32	830	6,230	300	1	~44	660	4,950
		350	0.5	~32	830	4,650	350	0.5	~32	830	5,810	350	0.5	~44	660	4,620
Die steel (1.2344, 1.2379) Below 255HB	JC8050 (JC8118) SPNW type SPMT-PM type	~150	1.5★	~32	1,020	7,340	~150	1.5★	~32	1,020	9,180	~150	1.5★	~44	810	7,290
		200	1.2★	~32	1,020	7,340	200	1.2★	~32	1,020	9,180	200	1.5★	~44	810	7,290
		250	0.8	~32	890	5,340	250	0.8	~32	890	6,680	250	1.2★	~44	710	5,330
		300	0.6	~32	830	4,980	300	0.6	~32	830	6,230	300	1	~44	660	4,950
		350	0.5	~32	830	4,650	350	0.5	~32	830	5,810	350	0.5	~44	660	4,620
Mold steel (1.2311,P20) 30-36HRC	JC8050 (JC8118) SPNW type SPMT-PM type	~150	1.5★	~32	1,020	7,340	~150	1.5★	~32	1,020	9,180	~150	1.5★	~44	810	7,290
		200	1.2★	~32	1,020	7,340	200	1.2★	~32	1,020	9,180	200	1.5★	~44	810	7,290
		250	0.8	~32	890	5,340	250	0.8	~32	890	6,680	250	1.2★	~44	710	5,330
		300	0.6	~32	830	4,980	300	0.6	~32	830	6,230	300	1	~44	660	4,950
		350	0.5	~32	830	4,650	350	0.5	~32	830	5,810	350	0.5	~44	660	4,620
Mold steel (1.2311,P21) 38-43HRC	JC8118 (JC8050) SPNW type SPMT-PM type	~150	1.2★	~32	700	4,200	~150	1.2★	~32	700	5,250	~150	1.2★	~44	560	4,200
		200	1	~32	700	4,200	200	1	~32	700	5,250	200	1.2★	~44	560	4,200
		250	0.7	~32	640	3,840	250	0.7	~32	640	4,800	250	1	~44	510	3,830
		300	0.6	~32	510	2,860	300	0.6	~32	510	3,570	300	0.5	~44	400	2,800
		350	-	-	-	-	350	-	-	-	-	350	-	-	-	-
Hardened die steel (1.2344, 1.2379) 42-52HRC	JC8118 SPNW type	~150	1	~32	640	3,580	~150	1	~32	640	4,480	~150	1	~44	510	3,570
		200	0.8	~32	640	3,330	200	0.8	~32	640	4,160	200	0.8	~44	510	3,320
		250	0.6	~32	640	3,070	250	0.6	~32	640	3,840	250	0.6	~44	510	3,060
		300	-	-	-	-	300	-	-	-	-	300	-	-	-	-
		350	-	-	-	-	350	-	-	-	-	350	-	-	-	-
Grey & Nodular cast iron (GG, GGG) Below 300HB	JC8118 SPNW type SPMT-PM type	~150	1.5★	~32	1,150	8,280	~150	1.5★	~32	1,150	10,350	~150	1.5★	~44	910	8,190
		200	1.5★	~32	1,150	8,280	200	1.5★	~32	1,150	10,350	200	1.5★	~44	910	8,190
		250	1.2★	~32	1,150	6,900	250	1.2★	~32	1,150	8,630	250	1.2★	~44	910	6,830
		300	0.8	~32	1,020	6,120	300	0.8	~32	1,020	7,650	300	0.8	~44	810	6,080
		350	0.5	~32	1,020	6,120	350	0.5	~32	1,020	7,650	350	0.5	~44	810	6,080
Stainless steel Below 250HB	JC7550 SPMT-SM type SPET-SM type	~150	1	~32	950	4,940	~150	1	~32	950	6,180	~150	1	~44	760	5,320
		200	1	~32	950	4,940	200	1	~32	950	6,180	200	1	~44	760	4,940
		250	0.8	~32	830	3,980	250	0.8	~32	830	4,980	250	0.8	~44	660	3,960
		300	0.6	~32	760	3,040	300	0.6	~32	760	3,800	300	0.6	~44	610	3,050
		350	0.4	~32	640	2,560	350	0.4	~32	640	3,200	350	0.5	~44	510	2,550
Titanium alloy (Ti-6Al-4V)	JC7550 SPMT-SM type SPET-SM type	~150	1	~32	380	910	~150	1	~32	380	1,140	~150	1	~44	300	900
		200	0.8	~32	380	910	200	0.8	~32	380	1,140	200	0.8	~44	300	900
		250	0.6	~32	380	760	250	0.6	~32	380	950	250	0.6	~44	300	750
		300	0.4	~32	380	610	300	0.4	~32	380	760	300	0.4	~44	300	600
		350	-	-	-	-	350	-	-	-	-	350	-	-	-	-

l : Overhung length a_p : Axial depth of cut a_e : Radial depth of cut n : Spindle speed V_f : Feed speed

Note:

- *1. The figure to be adjusted according to the machine rigidity or work rigidity.
- *2. In case of chatter occurring, recommend to reduce the depth of cut a_p or Spindle speed and keep feed per tooth.
- *3. If machine does not have enough power, recommend to reduce the depth of cut a_p or Spindle speed and Feed speed.
- *4. Use air blow.

★ : Reduce the depth of cut a_p to below 1.0mm in case of using SPMT / SPET type insert.

Work materials	Grades	Tool dia. (mm)									
		63/66					80				
		No. of teeth 6N					No. of teeth 6N				
		l (mm)	a_p (mm)	a_e (mm)	n (min ⁻¹)	V_f (mm/min)	l (mm)	a_p (mm)	a_e (mm)	n (min ⁻¹)	V_f (mm/min)
Carbon steel (C50,C55) Below 250HB	JC8050 (JC8118) SPNW type SPMT-PM type	~150	1.5★	~44	810	8,750	~150	1.5★	~60	640	6,910
		200	1.5★	~44	810	8,750	200	1.5★	~60	640	6,910
		250	1.2★	~42	710	6,390	250	1.2★	~55	560	5,040
		300	1	~42	660	5,940	300	1	~55	520	4,680
		350	0.5	~42	660	5,540	350	0.5	~55	520	4,370
Die steel (1.2344, 1.2379) Below 255HB	JC8050 (JC8118) SPNW type SPMT-PM type	~150	1.5★	~44	810	8,750	~150	1.5★	~60	640	6,910
		200	1.5★	~44	810	8,750	200	1.5★	~60	640	6,910
		250	1.2★	~42	710	6,390	250	1.2★	~55	560	5,040
		300	1	~42	660	5,940	300	1	~55	520	4,680
		350	0.5	~42	660	5,540	350	0.5	~55	520	4,370
Mold steel (1.2311,P20) 30-36HRC	JC8050 (JC8118) SPNW type SPMT-PM type	~150	1.5★	~44	810	8,750	~150	1.5★	~60	640	6,910
		200	1.5★	~44	810	8,750	200	1.5★	~60	640	6,910
		250	1.2★	~42	710	6,390	250	1.2★	~55	560	5,040
		300	1	~42	660	5,940	300	1	~55	520	4,680
		350	0.5	~42	660	5,540	350	0.5	~55	520	4,370
Mold steel (1.2311,P21) 38-43HRC	JC8118 (JC8050) SPNW type SPMT-PM type	~150	1.2★	~44	560	5,040	~150	1.2★	~60	440	3,960
		200	1.2★	~44	560	5,040	200	1.2★	~60	440	3,960
		250	1	~42	510	4,590	250	1	~55	400	3,600
		300	0.5	~42	400	3,360	300	0.5	~55	320	2,690
		350	-	-	-	-	350	-	-	-	-
Hardened die steel (1.2344, 1.2379) 42-52HRC	JC8118 SPNW type	~150	1	~44	510	4,280	~150	1	~60	400	3,360
		200	0.8	~44	510	3,980	200	0.8	~60	400	3,120
		250	0.6	~42	510	3,670	250	0.6	~55	400	2,880
		300	-	-	-	-	300	-	-	-	-
		350	-	-	-	-	350	-	-	-	-
Grey & Nodular cast iron (GG, GGG) Below 300HB	JC8118 SPNW type SPMT-PM type	~150	1.5★	~44	910	9,830	~150	1.5★	~60	720	7,780
		200	1.5★	~44	910	9,830	200	1.5★	~60	720	7,780
		250	1.2★	~42	910	8,190	250	1.2★	~55	720	6,480
		300	0.8	~42	810	7,290	300	0.8	~55	640	5,760
		350	0.5	~42	810	7,290	350	0.5	~55	640	5,760
Stainless steel Below 250HB	JC7550 SPMT-SM type SPET-SM type	~150	1	~44	760	6,380	~150	1	~60	600	5,040
		200	1	~44	760	5,930	200	1	~60	600	4,680
		250	0.8	~42	660	4,750	250	0.8	~55	520	3,740
		300	0.6	~42	610	3,660	300	0.6	~55	480	2,880
		350	0.5	~42	510	3,060	350	0.5	~55	400	2,400
Titanium alloy (Ti-6Al-4V)	JC7550 SPMT-SM type SPET-SM type	~150	1	~44	300	1,080	~150	1	~60	240	860
		200	0.8	~44	300	1,080	200	0.8	~60	240	860
		250	0.6	~42	300	900	250	0.6	~55	240	720
		300	0.4	~42	300	720	300	0.4	~55	240	580
		350	-	-	-	-	350	-	-	-	-

l : Overhung length a_p : Axial depth of cut a_e : Radial depth of cut n : Spindle speed V_f : Feed speed

Note:

*1. The figure to be adjusted according to the machine rigidity or work rigidity.

*2. In case of chatter occurring, recommend to reduce the depth of cut a_p or spindle speed and keep feed per tooth.

*3. If machine does not have enough power, recommend to reduce the depth of cut a_p or spindle speed and Feed speed.

*4. Use air blow.

★ : Reduce the depth of cut a_p to below 1.0mm in case of using SPMT / SPET type insert.

Recommended cutting conditions

SKG-14 Facemill type (Insert 14-type)

Work materials	Grades	Tool dia. (mm)														
		50/52					63					66				
		No. of teeth 4N					No. of teeth 4N					No. of teeth 5N				
		l (mm)	a_p (mm)	a_e (mm)	n (min ⁻¹)	V_f (mm/min)	l (mm)	a_p (mm)	a_e (mm)	n (min ⁻¹)	V_f (mm/min)	l (mm)	a_p (mm)	a_e (mm)	n (min ⁻¹)	V_f (mm/min)
Carbon steel (C50,C55) Below 250HB	JC8050 (JC8118) SPNW type SPMT-PM type	~150	2★	~28	890	6,410	~150	2★	~40	710	5,110	~150	2★	~44	680	6,120
		200	1.8	~28	890	6,410	200	1.8	~40	710	5,110	200	1.8	~44	680	6,120
		250	1.5	~28	830	4,980	250	1.5	~40	660	3,960	250	1.5	~44	630	4,730
		300	0.8	~28	760	4,560	300	0.8	~40	610	3,660	300	0.8	~44	580	4,350
		350	0.6	~28	640	3,580	350	0.6	~40	510	2,860	350	0.6	~44	480	3,360
Die steel (1.2344, 1.2379) Below 255HB	JC8050 (JC8118) SPNW type SPMT-PM type	~150	2★	~28	890	6,410	~150	2★	~40	710	5,110	~150	2★	~44	680	6,120
		200	1.8	~28	890	6,410	200	1.8	~40	710	5,110	200	1.8	~44	680	6,120
		250	1.5	~28	830	4,980	250	1.5	~40	660	3,960	250	1.5	~44	630	4,730
		300	0.8	~28	760	4,560	300	0.8	~40	610	3,660	300	0.8	~44	580	4,350
		350	0.6	~28	640	3,580	350	0.6	~40	510	2,860	350	0.6	~44	480	3,360
Mold steel (1.2311,P20) 30-36HRC	JC8050 (JC8118) SPNW type SPMT-PM type	~150	2★	~28	890	6,410	~150	2★	~40	710	5,110	~150	2★	~44	680	6,120
		200	1.8	~28	890	6,410	200	1.8	~40	710	5,110	200	1.8	~44	680	6,120
		250	1.5	~28	830	4,980	250	1.5	~40	660	3,960	250	1.5	~44	630	4,730
		300	0.8	~28	760	4,560	300	0.8	~40	610	3,660	300	0.8	~44	580	4,350
		350	0.6	~28	640	3,580	350	0.6	~40	510	2,860	350	0.6	~44	480	3,360
Mold steel (1.2311,P21) 38-43HRC	JC8118 (JC8050) SPNW type SPMT-PM type	~150	1.6	~28	640	3,840	~150	1.6	~40	510	3,060	~150	1.6	~44	480	3,600
		200	1.4	~28	640	3,840	200	1.4	~40	510	3,060	200	1.4	~44	480	3,600
		250	1.2	~28	640	3,840	250	1.2	~40	510	3,060	250	1.2	~40	480	3,600
		300	0.7	~28	510	2,860	300	0.7	~40	400	2,240	300	0.7	~40	390	2,730
		350	-	-	-	-	350	-	-	-	-	350	-	-	-	-
Hardened die steel (1.2344, 1.2379) 42-52HRC	JC8118 SPNW type	~150	1	~28	570	2,740	~150	1	~40	450	2,160	~150	1	~44	430	2,580
		200	1	~28	570	2,280	200	1	~40	450	1,800	200	1	~44	430	2,150
		250	0.8	~28	570	1,820	250	0.8	~40	450	1,440	250	0.8	~40	430	1,720
		300	0.5	~28	450	1,260	300	0.5	~40	350	980	300	0.5	~40	340	1,190
		350	-	-	-	-	350	-	-	-	-	350	-	-	-	-
Grey & Nodular cast iron (GG, GGG) Below 300HB	JC8118 SPNW type SPMT-PM type	~150	2★	~28	1,150	8,280	~150	2★	~40	910	6,550	~150	2★	~44	870	7,830
		200	1.8	~28	1,150	8,280	200	1.8	~40	910	6,550	200	1.8	~44	870	7,830
		250	1.5	~28	1,150	6,900	250	1.5	~40	910	5,460	250	1.5	~44	870	6,530
		300	0.8	~28	1,020	6,120	300	0.8	~40	810	4,860	300	0.8	~44	770	5,780
		350	0.6	~28	1,020	5,710	350	0.6	~40	810	4,540	350	0.6	~44	770	5,390
Stainless steel Below 250HB	JC7550 SPMT-SM type	~150	1.3	~28	950	4,940	~150	1.3	~40	760	4,260	~150	1.3	~44	760	5,320
		200	1.3	~28	950	4,940	200	1.3	~40	760	3,950	200	1.3	~44	760	4,940
		250	1.1	~28	830	3,980	250	1.1	~40	660	3,170	250	1.1	~40	660	3,960
		300	0.9	~28	760	3,040	300	0.9	~40	610	2,440	300	0.9	~40	610	3,050
		350	0.7	~28	640	2,560	350	0.7	~40	510	2,040	350	0.7	~40	510	2,550
Titanium alloy (Ti-6Al-4V)	JC7550 SPMT-SM type	~150	1.3	~28	380	910	~150	1.3	~40	300	720	~150	1.3	~44	300	900
		200	1.1	~28	380	910	200	1.1	~40	300	720	200	1.1	~44	300	900
		250	0.9	~28	380	760	250	0.9	~40	300	600	250	0.9	~40	300	750
		300	0.7	~28	380	610	300	0.7	~40	300	480	300	0.7	~40	300	600
		350	-	-	-	-	350	-	-	-	-	350	-	-	-	-

l : Overhung length a_p : Axial depth of cut a_e : Radial depth of cut n : Spindle speed V_f : Feed speed

- Note:
 *1. The figure to be adjusted according to the machine rigidity or work rigidity.
 *2. In case of chatter occurring, recommend to reduce the depth of cut a_p or Spindle speed and keep feed per tooth.
 *3. If machine does not have enough power, recommend to reduce the depth of cut a_p or Spindle speed and Feed speed.
 *4. Use air blow.

★ : Reduce the depth of cut a_p to below 1.8mm in case of using SPMT type insert.

Work materials	Grades	Tool dia. (mm)														
		80					100					125				
		No. of teeth 5N					No. of teeth 6N					No. of teeth 6N				
		l (mm)	a_p (mm)	a_e (mm)	n (min ⁻¹)	V_f (mm/min)	l (mm)	a_p (mm)	a_e (mm)	n (min ⁻¹)	V_f (mm/min)	l (mm)	a_p (mm)	a_e (mm)	n (min ⁻¹)	V_f (mm/min)
Carbon steel (C50,C55) Below 250HB	JC8050 (JC8118) SPNW type SPMT-PM type	~150	2★	~56	600	5,400	~150	2★	~70	480	5,180	~150	2★	~87	380	4,100
		200	1.8	~56	600	5,400	200	1.8	~70	480	5,180	200	1.8	~87	380	4,100
		250	1.5	~56	560	4,200	250	1.5	~70	450	4,050	250	1.5	~87	360	3,240
		300	0.8	~56	520	3,900	300	0.8	~70	410	3,690	300	0.8	~87	330	2,970
Die steel (1.2344, 1.2379) Below 255HB	JC8050 (JC8118) SPNW type SPMT-PM type	~150	2★	~56	600	5,400	~150	2★	~70	480	5,180	~150	2★	~87	380	4,100
		200	1.8	~56	600	5,400	200	1.8	~70	480	5,180	200	1.8	~87	380	4,100
		250	1.5	~56	560	4,200	250	1.5	~70	450	4,050	250	1.5	~87	360	3,240
		300	0.8	~56	520	3,900	300	0.8	~70	410	3,690	300	0.8	~87	330	2,970
Mold steel (1.2311,P20) 30-36HRC	JC8050 (JC8118) SPNW type SPMT-PM type	~150	2★	~56	600	5,400	~150	2★	~70	480	5,180	~150	2★	~87	380	4,100
		200	1.8	~56	600	5,400	200	1.8	~70	480	5,180	200	1.8	~87	380	4,100
		250	1.5	~56	560	4,200	250	1.5	~70	450	4,050	250	1.5	~87	360	3,240
		300	0.8	~56	520	3,900	300	0.8	~70	410	3,690	300	0.8	~87	330	2,970
Mold steel (1.2311,P21) 38-43HRC	JC8118 (JC8050) SPNW type SPMT-PM type	~150	1.6	~56	400	3,000	~150	1.6	~70	320	2,880	~150	1.6	~87	250	2,250
		200	1.4	~56	400	3,000	200	1.4	~70	320	2,880	200	1.4	~87	250	2,250
		250	1.2	~56	400	3,000	250	1.2	~70	320	2,880	250	1.2	~87	250	2,250
		300	0.7	~56	320	2,240	300	0.7	~70	250	2,100	300	0.7	~87	200	1,680
Hardened die steel (1.2311, 1.2379) 42-52HRC	JC8118 SPNW type	~150	1	~56	360	2,160	~150	1	~70	290	2,090	~150	1	~87	230	1,660
		200	1	~56	360	1,800	200	1	~70	290	1,740	200	1	~87	230	1,380
		250	0.8	~52	360	1,440	250	0.8	~60	290	1,390	250	0.8	~75	230	1,100
		300	0.5	~52	280	980	300	0.5	~60	220	920	300	0.5	~75	180	760
Grey & Nodular cast iron (GG, GGG) Below 300HB	JC8118 SPNW type SPMT-PM type	~150	2★	~56	720	6,480	~150	2★	~70	570	6,160	~150	2★	~87	460	4,970
		200	1.8	~56	720	6,480	200	1.8	~70	570	6,160	200	1.8	~87	460	4,970
		250	1.5	~56	720	5,400	250	1.5	~70	570	5,130	250	1.5	~87	460	4,140
		300	0.8	~56	640	4,800	300	0.8	~70	510	4,590	300	0.8	~87	410	3,690
Stainless steel Below 250HB	JC7550 SPMT-SM type	~150	1.5	~56	600	4,200	~150	1.5	~70	480	4,030	~150	1.5	~87	380	3,190
		200	1.5	~56	600	3,900	200	1.5	~70	480	3,740	200	1.5	~87	380	2,960
		250	1.3	~52	520	3,120	250	1.3	~60	410	2,950	250	1.3	~75	330	2,380
		300	1.1	~52	480	2,400	300	1.1	~60	380	2,280	300	1.1	~75	310	1,860
Titanium alloy (Ti-6Al-4V)	JC7550 SPMT-SM type	~150	1.3	~56	240	720	~150	1.3	~70	190	680	~150	1.3	~87	150	540
		200	1.1	~56	240	720	200	1.1	~70	190	680	200	1.1	~87	150	540
		250	0.9	~52	240	600	250	0.9	~60	190	570	250	0.9	~75	150	450
		300	0.7	~52	240	480	300	0.7	~60	190	460	300	0.7	~75	150	360
350	-	-	-	-	350	-	-	-	-	350	-	-	-	-		

l : Overhung length a_p : Axial depth of cut a_e : Radial depth of cut n : Spindle speed V_f : Feed speed

Note:

*1. The figure to be adjusted according to the machine rigidity or work rigidity.

*2. In case of chatter occurring, recommend to reduce the depth of cut a_p or Spindle speed and keep feed per tooth.

*3. If machine does not have enough power, recommend to reduce the depth of cut a_p or Spindle speed and

Feed speed.

*4. Use air blow.

★ : Reduce the depth of cut a_p to below 1.8mm in case of using SPMT type insert.

3/3

Work materials	Grades	Tool dia. (mm)				
		160				
		No. of teeth 7N				
		l (mm)	a_p (mm)	a_e (mm)	n (min ⁻¹)	V_f (mm/min)
Carbon steel (C50,C55) Below 250HB	JC8050 (JC8118) SPNW type SPMT-PM type	~150	2★	~112	300	3,780
		200	1.8	~112	300	3,780
		250	1.5	~112	280	2,940
		300	0.8	~112	260	2,730
		350	0.6	~112	220	2,160
Die steel (1.2344,1.2379) Below 255HB	JC8050 (JC8118) SPNW type SPMT-PM type	~150	2★	~112	300	3,780
		200	1.8	~112	300	3,780
		250	1.5	~112	280	2,940
		300	0.8	~112	260	2,730
		350	0.6	~112	220	2,160
Mold steel (1.2311,P20) 30-36HRC	JC8050 (JC8118) SPNW type SPMT-PM type	~150	2★	~112	300	3,780
		200	1.8	~112	300	3,780
		250	1.5	~112	280	2,940
		300	0.8	~112	260	2,730
		350	0.6	~112	220	2,160
Mold steel (1.2311,P21) 38-43HRC	JC8118 (JC8050) SPNW type SPMT-PM type	~150	1.6	~112	200	2,100
		200	1.4	~112	200	2,100
		250	1.2	~112	200	2,100
		300	0.7	~112	160	1,570
		350	-	-	-	-
Hardened die steel (1.2344, 1.2379) 42-52HRC	JC8118 SPNW type	~150	1	~112	180	1,510
		200	1	~112	180	1,260
		250	0.8	~100	180	1,010
		300	0.5	~100	140	690
		350	-	-	-	-
Grey & Nodular cast iron (GG, GGG) Below 300HB	JC8118 SPNW type SPMT-PM type	~150	2★	~112	360	4,540
		200	1.8	~112	360	4,540
		250	1.5	~112	360	3,780
		300	0.8	~112	320	3,360
		350	0.6	~112	320	3,140
Stainless steel Below 250HB	JC7550 SPMT-SM type	~150	1.5	~112	300	2,940
		200	1.5	~112	300	2,730
		250	1.3	~100	260	2,180
		300	1.1	~100	240	1,680
		350	0.9	~100	200	1,400
Titanium alloy (Ti-6Al-4V)	JC7550 SPMT-SM type	~150	1.3	~112	120	500
		200	1.1	~112	120	500
		250	0.9	~100	120	420
		300	0.7	~100	120	340
		350	-	-	-	-

l : Overhung length a_p : Axial depth of cut a_e : Radial depth of cut n : Spindle speed V_f : Feed speed

Note:

*1. The figure to be adjusted according to the machine rigidity or work rigidity.

*2. In case of chatter occurring, recommend to reduce the depth of cut a_p or Spindle speed and keep feed per tooth.

*3. If machine does not have enough power, recommend to reduce the depth of cut a_p or Spindle speed and Feed speed.

*4. Use air blow.

★ : Reduce the depth of cut a_p to below 1.8mm in case of using SPMT type insert.

Attention

⚠ Attention to mounting head and MSN/ MGN shank holder.

■ Tightening procedure

① Cleaning

Remove dirt and chips with air from the connecting thread and face of modular head and MSN/MGN shank holder.

② Initial Tightening

Tighten by hand until the head and the shank holder faces touch.

③ Final Tightening

Tighten slowly with torque control spanner wrench or DIJET DS type spanner wrench and confirm that there is no gap.

⚠ NOTE

Note) 1. Only use the torque control spanner wrench or DIJET DS type spanner wrench.

2. Please gently apply pressure on wrench.

3. Please confirm that there is no gap between MSN/MGN shank holder and modular head.

Thread	Tightening torque	Spanner size W(mm)
M6	8.0N·m	8☆
M8	16N·m	10, 12☆
M10	16N·m	14, 15
M12	20N·m	17, 19
M16	25N·m	22, 26

Note) 1. Modular heads are supplied without spanner wrench.

2. In case of choosing torque control spanner wrench, confirm that the wrench size is match to the dimensions W & C of each modular head.
(There are some cases that modifying the thickness of spanner wrench is necessary)

Attention : Final tightening without initial tightening cause connecting thread damage.

⚠ Selection of "MSN Carbide shank holder"

In case of using modular head over $\varphi 16\text{mm}$, please select MSN carbide shank that diameter ($\varphi D1$) is 1mm or more smaller than modular head (φDc). A wrong selection causes damage to the carbide shank.

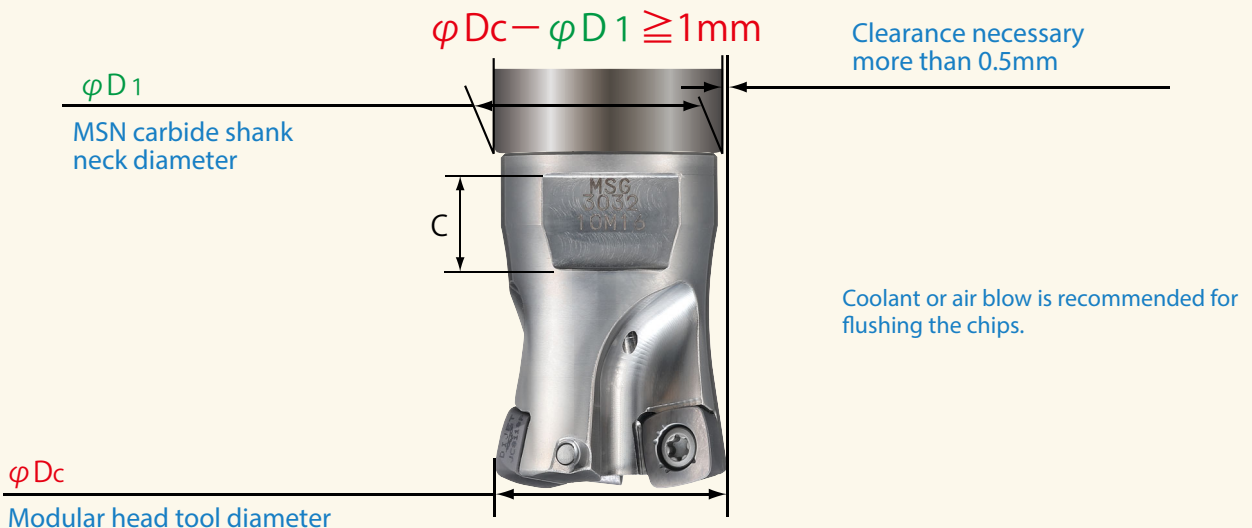

⚠ Caution for the mounting to shrink fit holder.

When you use a carbide shank and a modular head on the shrink fit holder, please shrink fit the only carbide shank without mounting a modular head together. Please mount a modular head after shrinking fit operation.

Note) In case of shrink fit MSN shank + modular head together, it will be difficult to loose due to heat desipation.



HEADQUARTER

DIJET Industrial Co.Ltd.

1-1-18, Kami-Higashi,

Hirano-ku, Osaka 547-0002, Japan

PHONE +81-6-6791-6781

FAX +81-6-6793-1221

MAIN OFFICE EUROPE

DIJET GmbH

Immermannstraße 9

40210 Düsseldorf, Germany

PHONE +49-211-50088820

FAX +49-211-50088823



DIJET EUROPE



DIJET GmbH



Web : www.dijet.de

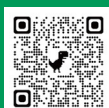

Please register to DIJET-Club

dijet-club.com →



ZIBTR PRO
tehnologija obdelave · vpenjalni sistemi