

PRODUCT NEWS

PN-E-008

SERIES EXPANSION

NEW

High efficient roughing tool

DIJET[®]

“QM MAX G II”

GMX / MXG type

- Face mill type: $\phi 50 \sim \phi 66$
- Endmill shank type: $\phi 16 \sim \phi 32$
- Modular type: $\phi 16 \sim \phi 42$



DIJET GmbH

www.dijet.de

Features of product

Greatly improved metal removal rate!
For high efficient roughing. Wide application range.



Excellent chip evacuation
Q=317cm³/min
(φ50×7N)
(Insert: ENMU-PH type)

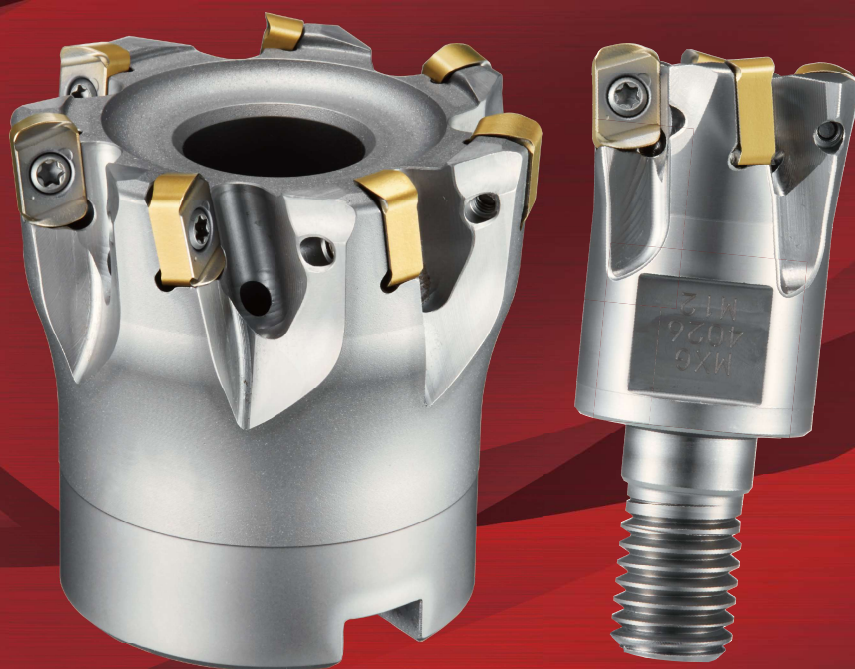

Feature 1

Inserts with optimum cutting edge for its use.

※Compared with conventional positive type cutter, chips thickness of QM MAX G II reduced by 14%
(in case of $a_p=0.6\text{mm}$, insert No.:ENMU-PH).



ENMU type (with breaker insert)

Low cutting force inserts
for high feed machining.

Negative insert

Optimum cutting edge



ENMQ type (non-breaker insert)

Inserts with strengthened cutting edge
for high hardened materials.

Feature 2

Economical double-side insert (4 corners). 4 shapes & 7 type inserts are available.

They can be widely applied from general steel to hard-to-cut materials such as hardened die steel (up to 62HRC), high strength stainless steel, titanium alloy & inconel.

Line up

Sharpness

Strength



ENMU100412ZER-SL

Breaker with low cutting force
Sharpe & wavy cutting edge
Grade : JC7550, JC7518



ENMU100412ZER-PH

Breaker for general use
Strong & wavy cutting edge
Grade : JC8118, JC8050, JC7560



ENMU100312ZER-HL

Breaker for high hardened material
Secure strength by straight cutting edge & low breaker angle
Grade : DH102
For high hardened material up to



ENMQ100312ZER

Non-breaker
Polishing top & bottom surface
Grade : DH102
For high hardened material over 60HRC

Page 9 Application for the choice of inserts

Application

ISO	P				M				K				S				H			
	P01	P10	P20	P30	P40	M01	M10	M20	M30	M40	K01	K10	K20	K30	S01	S10	S20	S30	H01	H10
Applicable range	JC8118				JC8118				DH102				DH102				DH102			
	JC8050				JC8050				JC8118				JC8118				JC8118			
	NEW JC7518				NEW JC7518				JC8050				JC8050				NEW JC7518			
	JC7550				JC7550				JC8050				NEW JC7518				NEW JC7518			
	JC7560				JC7560				JC7560				JC7550				JC7550			
	JC7560				JC7560				JC7560				JC7560				JC7560			

Feature 3

Possible to stable high feed machining in case of long overhung length over L/D=6 .

Feature 4

Excellent in ramping and helical interpolation, and possible to high efficient pocket milling.
※Max. ramping angle 1° in case of using φ25 tool dia.

Cutting performance

Cutting force comparison

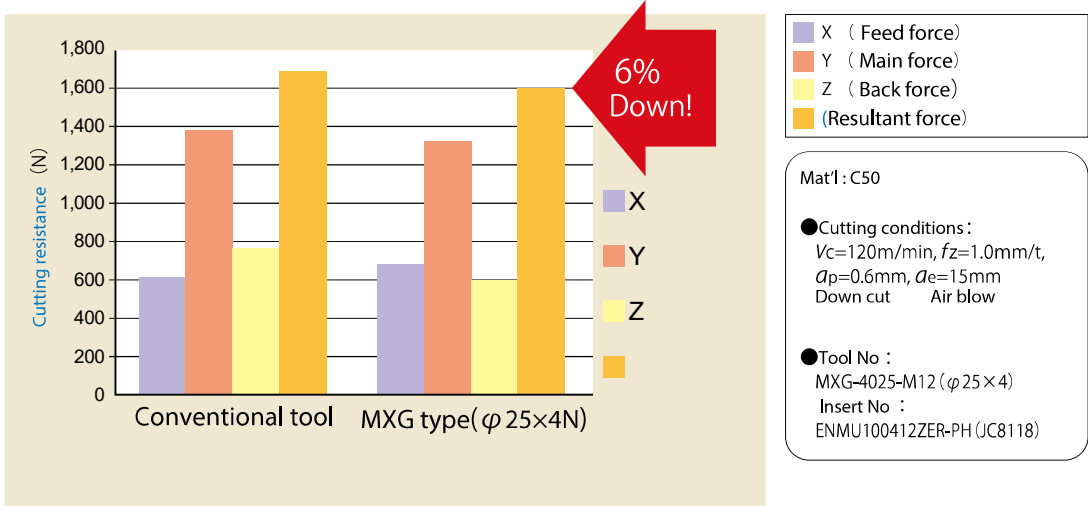

Feed limit comparison

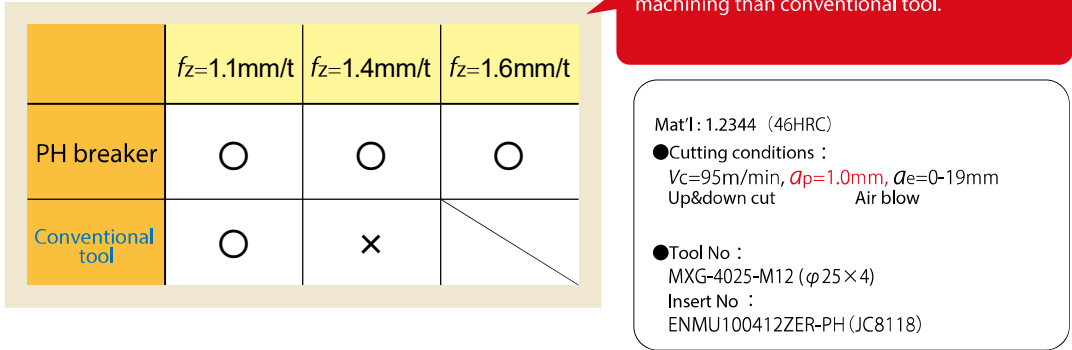

Tool life comparison

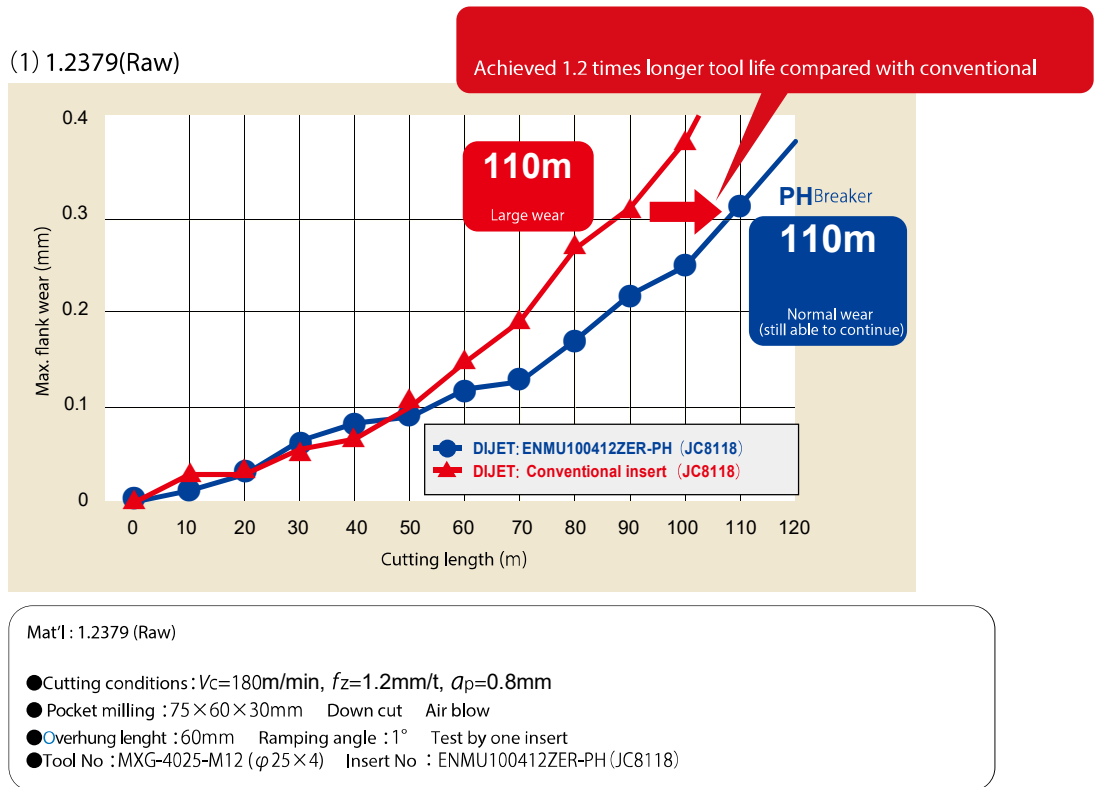

Tool life comparison

(2) Ti-6Al-4V Titanium alloy

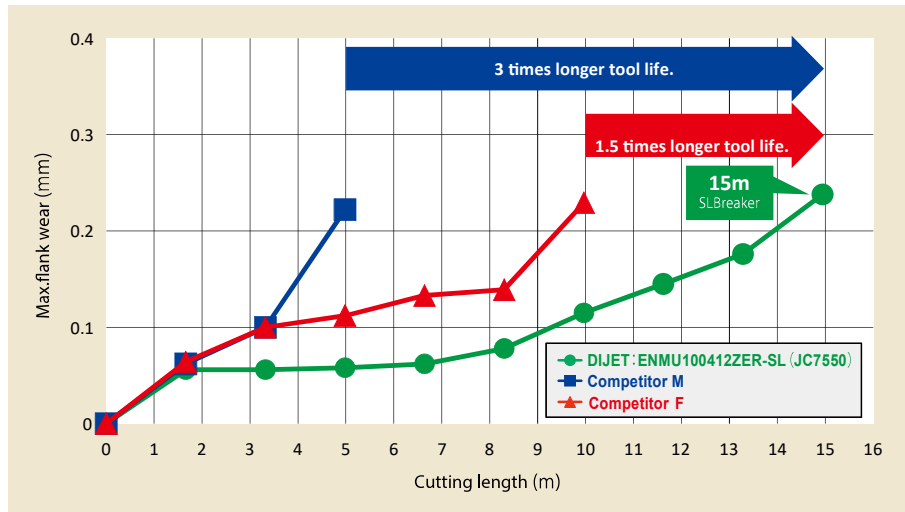

Mat1: Titanium alloy

● Cutting conditions: $V_c=60\text{m/min}$, $f_z=0.7\text{mm/t}$, $a_p=0.5\text{mm}$, $a_e=15\text{mm}$

Down cut Wet (external coolant) Test by one insert

● Tool No: MXG-4025-M12 ($\varnothing 25 \times 4$)

Insert No: ENMU100412ZER-SL (JC7550)

Tool life comparison

(3) SKD11(60HRC)

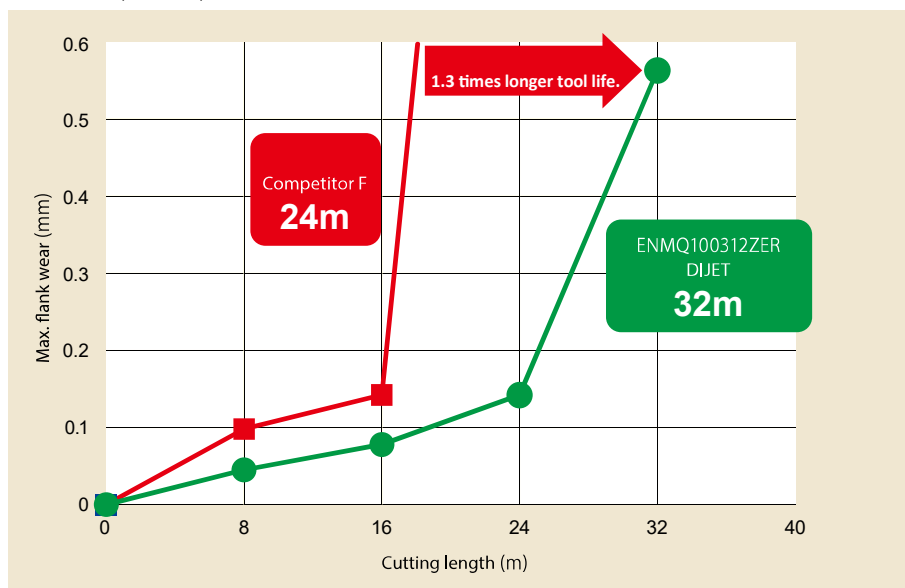

Mat1: 1.2379

● Cutting conditions: $V_c=80\text{m/min}$, $f_z=0.3\text{mm/t}$, $a_p=0.2\text{mm}$, $a_e=15\text{mm}$

Down cut Air blow(External) Test by 4 inserts

● Tool No: MXG-4025-M12($\varnothing 25 \times 4$)

Insert No: ENMQ100312ZER(DH102)

Line up

● Facemill type



● Through coolant hole

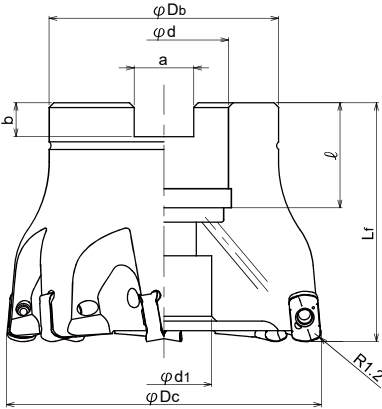

● Body

Type	Item code	Stock	No. of inserts	Dimensions (mm)								Applicable inserts
				ϕDc	Lf	ϕDb	ϕd	$\phi d1$	a	b	l	
Metric Bore	GMX-7050R-22	●	7	50	50	40	22	17	10.4	6.3	20	ENMU100412ZER-*** ENM*100312ZER-***
	GMX-7052R-22	●	7	52	50	40	22	17	10.4	6.3	20	
	GMX-7063R-22	●	7	63	50	48	22	17	10.4	6.3	20	
	GMX-7066R-22	●	7	66	50	48	22	17	10.4	6.3	20	
	GMX-7066R-27	●	7	66	50	48	27	20	12.4	7	22	

●: Standard stock items
 ☆: Stock in Japan. (14 days delivery upon ordering)
 Note) 1. All cutters are supplied without inserts.
 2. All cutters are supplied without wrench & MOLY.



Parts	
Clamp screw TSW-2567H	Wrench (not be included) A-08
Clamp screw TSW-2567H	(N·m) Recommended torque 1.1



Adopted GN surface-hardening treatment on thermal resistant high strength steel gives high hardness over 65HRC and secure insert pocket and holder against thermal deformation, improved body durability and tool life by 30% or more. Make it difficult to be damaged even under severe cutting conditions. Also rust-proof and anti-welding effect is much improved.

End Mill type



Through coolant hole

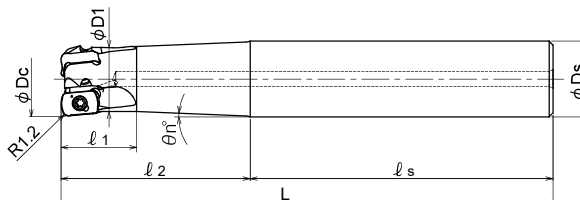

Body

Item code	Stock	No. of inserts	Dimensions (mm)							Applicable inserts	Parts		
			ϕDc	l_1	l_2	l_s	L	$\phi D1$	ϕDs		θn°	Clamp screw	Wrench (not be included)
GMX-2016-30-S16	☆	2	16	16	30	70	100	14	16	35°	ENMU100412ZER-*** ENM*100312ZER-***	TSW-2567H	A-08
GMX-2016-50-S16	☆	2	16	16	50	100	150	14	16	12°			
GMX-3020-50-S20	☆	3	20	20	50	80	130	17.2	20	2.3°			
GMX-3020-80-S20	☆	3	20	20	80	80	160	17.2	20	1°			
GMX-4025-60-S25	☆	4	25	25	60	80	140	22	25	2°			
GMX-4025-100-S25	☆	4	25	25	100	80	180	22	25	0.9°			
GMX-5032-70-S32	☆	5	32	30	70	80	150	29	32	1.5°			
GMX-5032-120-S32	☆	5	32	30	120	80	200	29	32	0.6°			

●: Standard stock items ☆: Stock in Japan. (14 days delivery upon ordering)

Note) 1. All cutters are supplied without inserts.
2. All cutters are supplied without wrench & MOLY.

Clamp screw	(N·m) Recommended torque
TSW-2567H	1.1

Line up

● Modular head type



● Through coolant hole

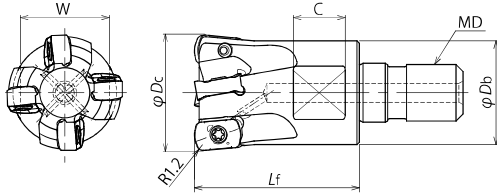

● Body

Item code	Stock	No. of inserts	Dimensions (mm)					Applicable inserts	Parts		
			φDc	Lf	φDb	MD	C		W	Clamp screw	Wrench (not be included)
MXG-2016-M8	●	2	16	23	14	M8	8	12	ENMU100412ZER-** ENM*100312ZER-**	TSW-2567H	A-08
MXG-2017-M8	●	2	17	23	14	M8	8	12			
MXG-3020-M10	●	3	20	30	18	M10	9	14			
MXG-3021-M10	●	3	21	30	18	M10	9	14			
MXG-3025-M12	●	3	25	35	22	M12	11	19			
MXG-4025-M12	●	4	25	35	22	M12	11	19			
MXG-4026-M12	●	4	26	35	22.5	M12	11	19			
MXG-5030-M16	☆	5	30	43	27	M16	12	22			
MXG-5032-M16	●	5	32	43	29	M16	12	22			
MXG-5035-M16	●	5	35	43	29	M16	12	22			
MXG-6040-M16	●	6	40	43	32	M16	14	26			
MXG-6042-M16	●	6	42	43	32	M16	14	26			

●: Standard stock items
 ☆: Stock in Japan. (14 days delivery upon ordering)

Note) 1. All cutters are supplied without inserts.
 2. Please see page 12 for recommended tightening torque.
 3. All cutters are supplied without wrench & MOLY.

Clamp screw	(N·m) Recommended torque
TSW-2567H	1.1



● Insert

ENMU100412ZER-PH



ENMU100412ZER-SL



NEW ENMU100312ZER-HL



NEW ENMQ100312ZER

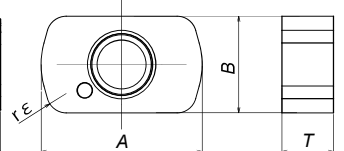
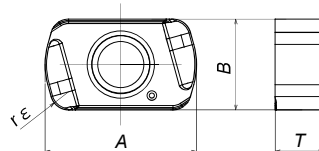
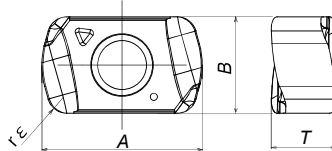
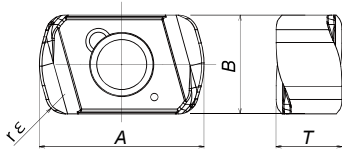

Item code	Tolerance	PVD Coated					Dimensions (mm)				
		DH102	JC8118	JC7518	JC8050	JC7550	JC7560	A	B	T	rE
ENMU100412ZER-PH	M		●		NEW ●		●	10	6	4	1.2
ENMU100412ZER-SL	M			NEW ●		●		10	6	4	1.2
NEW ENMU100312ZER-HL	M	●						10	6	3.2	1.2
NEW ENMQ100312ZER	M	●						10	6	3.2	1.2

●: Standard stock items

10 inserts per case.

Parts	
Clamp screw	Wrench (not be included)
TSW-2567H	A-08

Clamp screw	(N·m) Recommended torque
TSW-2567H	1.1

● Discrimination of grade for insert.

Each grade shows discrimination mark on the insert surface.

ENMU100412ZER-PH

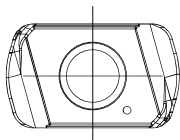

JC8118

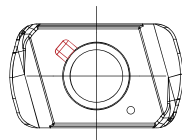

JC8050

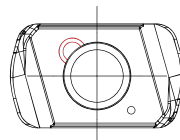

JC7560

ENMU100412ZER-SL

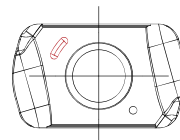

JC7518

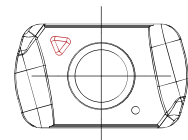

JC7550



Application for the choice of inserts

Work materials	Insert No.	Item code			
		ENMU100412ZER-PH	ENMU100412ZER-SL	ENMU100312ZER-HL	ENMQ100312ZER
Breaker		For general use	Low cutting force	For hardened material	Non-breaker
Carbon steel (C50, C55) Below 250HB	JC8118	○			
	JC8050	◎			
	JC7560	●			
	JC7550				
	JC7518		☆		
	DH102				
Die steel (1.2344, 1.2379) Below 255HB	JC8118	○			
	JC8050	◎			
	JC7560	●			
	JC7550				
	JC7518		☆		
	DH102				
Mold steel (1.2311, P20) 30~36HRC	JC8118	○			
	JC8050	◎			
	JC7560	●			
	JC7550				
	JC7518		☆		
	DH102				
Mold Steel (1.2311, P21) 38~43HRC	JC8118	◎			
	JC8050	●			
	JC7560				
	JC7550				
	JC7518		☆		
	DH102				
Hardened die steel (1.2344, 1.2379) 42~52HRC	JC8118	◎			
	JC8050				
	JC7560				
	JC7550				
	JC7518		☆		
	DH102			●	
Hardened die steel (1.2344, 1.2379) 55~62HRC	JC8118	×			
	JC8050	×			
	JC7560	×			
	JC7550		×		
	JC7518		×		
	DH102			○	◎
Cast iron (GG, GGG) Below 300HB	JC8118	◎			
	JC8050	○			
	JC7560	●			
	JC7550				
	JC7518				
	DH102				
Stainless steel Below 250HB	JC8118				
	JC8050	●			
	JC7560				
	JC7550		◎		
	JC7518		○		
	DH102				
Titanium alloy	JC8118				
	JC8050	●			
	JC7560				
	JC7550		◎		
	JC7518		○		
	DH102				
Inconel	JC8118				
	JC8050	●			
	JC7560				
	JC7550		○		
	JC7518		◎		
	DH102				

◎: First choice, good condition ○: Moderate condition ●: Unfavorable condition ☆: Light cutting ×: No good

Line up

MSN Carbide shank arbor

End mill shank type

- Through coolant hole
- For high productivity

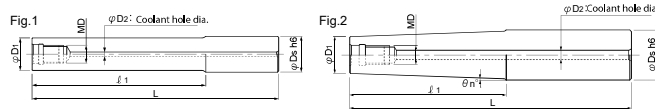

Item code	Stock	Dimensions (mm)					MD	φD2	Weight (kg)	Fig.
		φDs	ℓ1	L	φD1	θn°				
MSN-M8-20-S16C	●	16	20	75	15.5	-	M8	4	0.17	1
MSN-M8-40-S16C	●	16	40	95	15.5	-			0.22	1
MSN-M8-40T-S20C	☆	20	40	100	14.5	3°30'			0.36	2
MSN-M8-77T-S20C	●	20	77	143	14.5	1°45'			0.49	2
MSN-M8-80-S16C	●	16	80	135	15.5	-			0.32	1
MSN-M8-120-S16C	●	16	120	175	15.5	-			0.42	1
MSN-M8-152-S16C	●	16	152	207	15.5	-			0.51	1
MSN-M10-20-S20C	●	20	20	80	19.5	-			0.29	1
MSN-M10-40-S20C	●	20	40	100	19.5	-			0.39	1
MSN-M10-40T-S20C	●	20	40	100	18.5	0°43'			0.39	2
MSN-M10-70-S20C	●	20	70	130	19.5	-	0.50	1		
MSN-M10-85T-S25C	●	25	85	161	18.5	2°	0.90	2		
MSN-M10-90-S20C	●	20	90	150	19.5	-	0.60	1		
MSN-M10-90T-S20C	●	20	90	150	18.5	0°19'	0.58	2		
MSN-M10-140-S20C	●	20	140	200	19.5	-	0.80	1		
MSN-M10-140T-S20C	●	20	140	200	18.5	0°12'	0.77	2		
MSN-M10-160-S20C	●	20	160	220	19.5	-	0.87	1		
MSN-M10-210-S20C	●	20	210	270	19.5	-	1.07	1		
MSN-M12-25-S25C	●	25	25	90	24	-	0.53	1		
MSN-M12-55-S25C	●	25	55	120	24	-	0.72	1		
MSN-M12-100T-S32C	☆	32	100	180	23.5	2°	1.61	2		
MSN-M12-105-S25C	●	25	105	170	24	-	1.03	1		
MSN-M12-135-S25C	●	25	135	215	24	-	1.30	1		
MSN-M12-155-S25C	●	25	155	220	24	-	1.34	1		
MSN-M12-200-S25C	●	25	200	265	24	-	1.58	1		
MSN-M16-25-S32C	●	32	25	90	29	-	0.85	1		
MSN-M16-55-S32C	●	32	55	120	29	-	1.13	1		
MSN-M16-77-S32C	●	32	77	157	29	-	1.47	1		
MSN-M16-97-S32C	●	32	97	177	29	-	1.64	1		
MSN-M16-105-S32C	●	32	105	170	29	-	1.59	1		
MSN-M16-117T-S32C	☆	32	117	197	29	0°38'	1.88	2		
MSN-M16-127-S32C	●	32	127	207	29	-	1.89	1		
MSN-M16-127T-S32C	☆	32	127	207	29	0°30'	2.23	2		
MSN-M16-155-S32C	●	32	155	220	29	-	2.04	1		
MSN-M16-177-S32C	●	32	177	257	29	-	2.32	1		
MSN-M16-177T-S32C	●	32	177	257	29	0°23'	2.78	2		
MSN-M16-195-S32C	●	32	195	260	29	-	2.40	1		
MSN-M16-197T-S32C	☆	32	197	277	29	0°23'	3.00	2		
MSN-M16-225-S32C	●	32	225	290	29	-	2.57	1		
MSN-M16-245-S32C	●	32	245	310	29	-	2.74	1		
MSN-M16-295-S32C	●	32	295	360	29	-	3.17	1		

- : Standard stock items
- ☆: Stock in Japan. (14 days delivery upon ordering)

Note) Please see page 12 for recommended tightening torque.

Straight arbor type

- Through coolant hole
- For high productivity

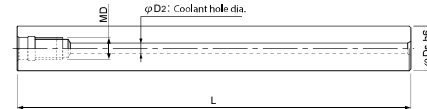

Item code	Stock	Dimensions (mm)				Weight (kg)
		φDs	L	MD	φD2	
MSN-M8-87S-S14C	●	14	87	M8	4	0.16
MSN-M8-137S-S14C	●		137			0.26
MSN-M8-97S-S15C	●	15	97	M8	4	0.21
MSN-M8-147S-S15C	●		147			0.33
MSN-M8-197S-S15C	●		197			0.44
MSN-M8-107S-S16C	●	16	107	M8	4	0.27
MSN-M8-157S-S16C	●		157			0.40
MSN-M10-130S-S18C	●	18	130	M10	4	0.42
MSN-M10-190S-S18C	●		190			0.62
MSN-M10-240S-S18C	●		240			0.89
MSN-M10-130S-S20C	●	20	130	M10	4	0.53
MSN-M10-190S-S20C	●		190			0.78
MSN-M10-250S-S20C	●		250			1.02
MSN-M12-185S-S23C	●	23	185	M12	6	0.98
MSN-M12-265S-S23C	●		265			1.42
MSN-M12-185S-S24C	●	24	185	M12	6	1.07
MSN-M12-265S-S24C	●		265			1.54
MSN-M12-145S-S25C	●	25	145	M12	6	0.91
MSN-M12-215S-S25C	●		215			1.36
MSN-M12-285S-S25C	●		285			1.80
MSN-M16-160S-S28C	●	28	160	M16	8	1.22
MSN-M16-230S-S28C	●		230			1.77
MSN-M16-310S-S28C	●		310			2.41
MSN-M16-157S-S32C	●	32	157	M16	8	1.61
MSN-M16-217S-S32C	●		217			2.22
MSN-M16-287S-S32C	●		287			2.94
MSN-M16-357S-S32C	●		357			3.66

- : Standard stock items
 - ☆: Stock in Japan. (14 days delivery upon ordering)
- Note) Please see page 12 for recommended tightening torque.

MGN G-Body steel shank arbor

- Adopted ultra-rigid and improved body durability "G-Body".
- Short type
- Cost-effective and high strength steel shank arbor.

■ End mill shank type

- Through coolant hole

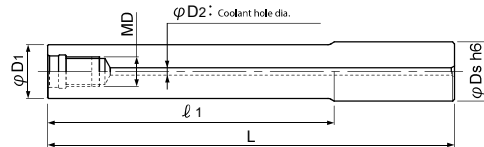

Item code	Stock	Dimensions (mm)							Weight (kg)
		ϕD_s	ℓ_1	L	ϕD_1	θ n°	MD	ϕD_2	
MGN-M8-17-S16	☆	16	17	97	15.5	—	M8	4	0.13
MGN-M10-30-S20	☆	20	30	100	19	—	M10	4	0.21
MGN-M12-35-S25	☆	25	35	105	24	—	M12	4	0.36
MGN-M12-85-S25	☆	25	85	165	24	—	M12	4	0.57
MGN-M16-37-S32	☆	32	37	107	29	—	M16	6	0.56
MGN-M16-77-S32	☆	32	77	157	29	—	M16	6	0.83

●: Standard stock items

☆: Stock in Japan. (14 days delivery upon ordering)

Note) 1. In case of using modular head combined with MGN steel shank arbor, apply the recommended cutting conditions sheet (see page 16-22).

2. Please see page 12 for recommended tightening torque.

Attention

⚠ Attention to mounting head and MSN/ MGN shank arbor.

■ Tightening procedure

① Cleaning

Remove dirt and chips with air from the connecting thread and face of modular head and MSN/MGN shank arbor.

② Initial Tightening

Tighten by hand until the head and the shank arbor faces touch.

③ Final Tightening

Tighten slowly with torque control spanner wrench or DIJET DS type spanner wrench and confirm that there is no gap.

⚠ NOTE

Note) 1. Only use the torque control spanner wrench or DIJET DS type spanner wrench.
2. Please gently apply pressure on wrench.
3. Please confirm that there is no gap between MSN/MGN shank arbor

Thread	Tightening torque	Spanner size
M6	8.0N·m	8☆
M8	16N·m	10, 12☆
M10	16N·m	14, 15
M12	20N·m	17, 19
M16	25N·m	22, 26

Note) 1. Modular heads are supplied without spanner wrench.
2. In case of choosing torque control spanner wrench, confirm that the wrench size is match to the dimensions W & C of each modular head.
(There are some cases that modifying the thickness of spanner wrench is necessary)

Attention : Final tightening without initial tightening cause connecting thread damage

⚠ Selection of "MSN Carbide shank arbor"

In case of using modular head over $\varnothing 16\text{mm}$, please select MSN carbide shank arbor that diameter ($\varnothing D1$) is 1mm or more smaller than modular head ($\varnothing Dc$). A wrong selection causes damage to the carbide shank.

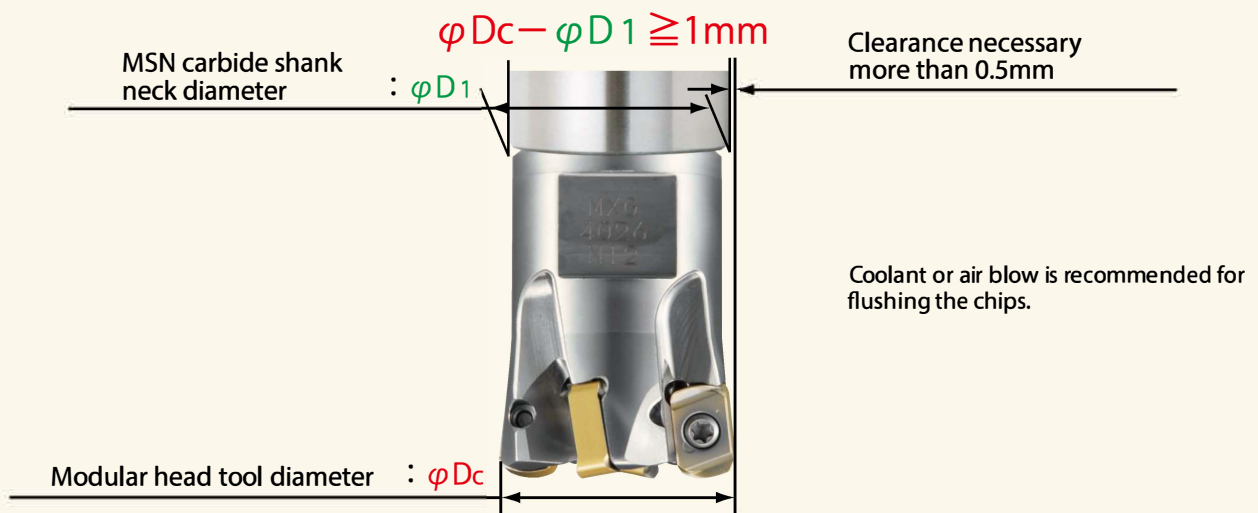

⚠ Caution for the mounting to shrink fit holder.

When you use a carbide shank and a modular head on the shrink fit holder, please shrink fit the only carbide shank without mounting a modular head together. Please mount a modular head after shrinking fit operation.

Note) In case of shrink fit MSN shank + modular head together, it will be difficult to loose due to heat desipation.

Cutting data

1. Machining on Plastic mold

Overhung length : 100mm Gauge length : 250mm

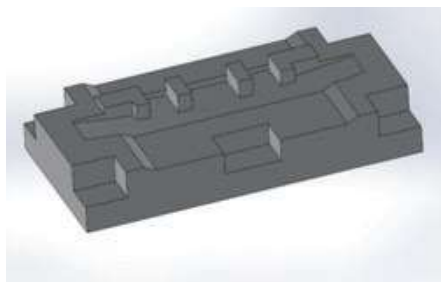

Result

Achieved high metal removal rate ($Q=229.2\text{cm}^3/\text{min}$). After machining for 3h30min, insert showed normal wear.

Work	Part name	Plastic mold		
	Material	S55C C55		
	Hardness	—		
Tool	Tool No.	MXG-5035-M16		
	Insert No.	ENMU100412ZER-PH(JC8118)		
Cutting conditions	Spindle speed	n	1,910 (min ⁻¹)	
	Cutting speed	V_c	210 (m/min)	
	Feed speed	V_f	11,460 (mm/min)	
		f	1.2 (mm/t)	
	a_p		0.8 (mm)	
	a_e		25 (mm)	
	Coolant		DRY	
Machine		Vertical MC		

4033

2. Machining on Stainless steel

Overhung length : 60mm

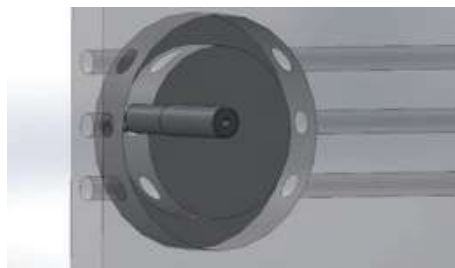

Result

Circular grooving while ramping. Competitor machined only 2 or 3 works, but DIJET finished 3 works and showed normal wear (still able to continue).

Work	Part name	Machine parts		
	Material	SUS304		
	Hardness	—		
Tool	Tool No.	MXG-3020-M10		
	Insert No.	ENMU100412ZER-SL(JC7550)		
Cutting conditions	Spindle speed	n	1,600 (min ⁻¹)	
	Cutting speed	V_c	100 (m/min)	
	Feed speed	V_f	3,200 (min) Part of crossed hole 2,400 (min)	
		f	0.66 (m/min) Part of crossed hole 0.5 (m/min)	
	a_p		0.3 (mm)	
a_e		20 (mm)		
Coolant		Wet (Internal)		
Machine		Horizontal MC (BT50)		

4002

3. Machining on High hardened material

Overhung length : 155mm Face milling (roughing)
Size : 145mm × 98mm × 82mm

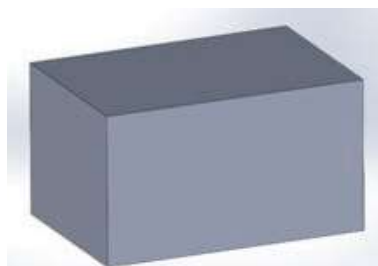

Result

Machining time: 3 hours per corner. Cutting length: 225m. Possible to stable machining from beginning to end.

Work	Part name	Test piece		
	Material	SKD11 1.2379		
	Hardness	60-63HRC		
Tool	Tool No.	MXG-5032-M16		
	Insert No.	ENMQ100312ZER(DH102)		
Cutting conditions	Spindle speed	n	800 (min ⁻¹)	
	Cutting speed	V_c	80 (m/min)	
	Feed speed	V_f	1,200 (mm/min)	
		f	0.3 (mm/t)	
	a_p		0.2 (mm)	
a_e		16 (mm)		
Coolant		Air blow (External)		
Machine		Vertical MC		

4225

Definition of corner shape for programming

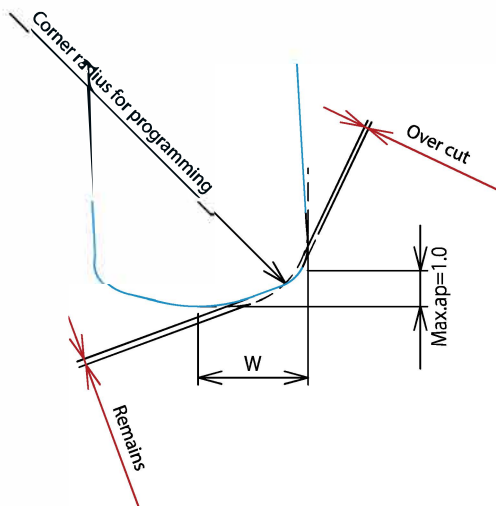

Insert No.	W	Corner radius for programming	Remains	Over cut
ENMU100412ZER-PH	3.1	1.0	0.51	0
ENMU100412ZER-SL		1.5 (Standard)	0.36	0
		2.0	0.22	0.05

(mm)

Insert No.	W	Corner radius for programming	Remains	Over cut
ENMU100312ZER-HL	3.3	1.0	0.55	0
ENMQ100312ZER		1.5 (Standard)	0.41	0
		2.0	0.26	0.04

(mm)

Attention for profile milling

Ramping

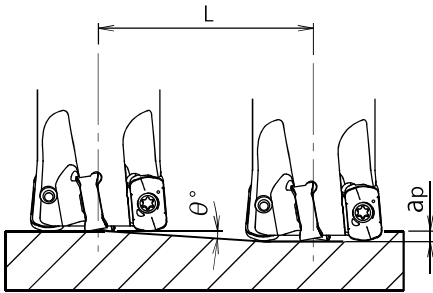

Helical interpolation

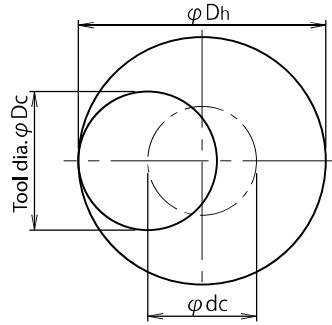

- Calculation of tool pass dia.

$$\varphi_{dc} = \varphi_{Dh} - \varphi_{Dc}$$

Tool pass dia. Bore dia. Tool dia.

- Depth of cut per one circuit should not exceed max. depth of cut a_p .
- Down cutting is recommended, so tool pass rotation should be counterclockwise.

- In case of ramping and helical interpolation, apply 70% or less feed speed from standard cutting condition table.
- In case of drilling, apply 20% or less Z axis feed speed from standard cutting condition table.
- Long consecutive chips may come out in case of drilling, confirm the safe condition sufficiently.

Item code	Tool dia.(mm)	Eff. Cutting dia.(mm)		a_p Max. depth of cut (mm)	Ramping	
		Insert No.			Max. ramping angle θ°	L (mm) Total cutting length at Max. a_p
		ENMU100412ZER-***	ENM***100312ZER-***			
MXG-2016-M8	16	10.1	9.6	0.7	1°36'	25.1
MXG-2017-M8	17	11	10.5	0.7	1°36'	25.1
MXG-3020-M10	20	13.9	13.5	1	1°30'	38.2
MXG-3021-M10	21	14.9	14.5	1	1°30'	38.2
MXG- * 025-M12	25	18.9	18.4	1	1°12'	47.7
MXG-4026-M12	26	19.9	19.4	1	1°12'	47.7
MXG-5030-M16	30	23.9	23.4	1	0°54'	63.6
MXG-5032-M16	32	25.8	25.4	1	0°54'	63.6
MXG-5035-M16	35	28.8	28.4	1	0°42'	81.8
MXG-6040-M16	40	33.8	33.4	1	0°30'	114.5
MXG-6042-M16	42	35.8	35.4	1	0°30'	114.5
GMX-2016- * *-S16	16	10.1	9.6	0.7	1°36'	25.1
GMX-3020- * *-S20	20	13.9	13.5	1	1°30'	38.2
GMX-4025- * *-S25	25	18.9	18.4	1	1°12'	47.7
GMX-5032- * *-S32	32	25.8	25.4	1	0°54'	63.6
GMX-7050R- * *	50	43.8	43.4	1	0°24'	143.2
GMX-7052R-22	52	45.8	45.4	1	0°24'	143.2
GMX-7063R- * *	63	56.8	56.4	1	0°18'	190.9
GMX-7066R- * *	66	59.8	59.4	1	0°18'	190.9

Item code	Tool dia.(mm)	Helical interpolation			Z Max. drilling depth(mm)	
		Min. bore dia. Dh min (mm)		Max. bore dia. Dh max (mm)	Insert No.	
		ENMU100412ZER-***	ENM***100312ZER-***		ENMU100412ZER-***	ENM***100312ZER-***
MXG-2016-M8	16	22	21	30	0.3	0.2
MXG-2017-M8	17	24	23	32	0.3	0.2
MXG-3020-M10	20	30	29	38	0.4	0.2
MXG-3021-M10	21	32	31	40	0.4	0.2
MXG- * 025-M12	25	40	39	48	0.5	0.3
MXG-4026-M12	26	42	41	50	0.5	0.3
MXG-5030-M16	30	50	49	58	0.6	0.4
MXG-5032-M16	32	54	53	62	0.6	0.4
MXG-5035-M16	35	60	59	68	0.6	0.4
MXG-6040-M16	40	70	69	78	0.7	0.5
MXG-6042-M16	42	74	73	82	0.7	0.5
GMX-2016- * *-S16	16	22	21	30	0.3	0.2
GMX-3020- * *-S20	20	30	29	38	0.4	0.2
GMX-4025- * *-S25	25	40	39	48	0.5	0.3
GMX-5032- * *-S32	32	54	53	62	0.6	0.4
GMX-7050R- * *	50	90	89	98	0.8	0.6
GMX-7052R-22	52	94	93	102	0.8	0.6
GMX-7063R- * *	63	116	115	124	0.8	0.6
GMX-7066R- * *	66	122	121	130	0.8	0.6

Recommended cutting conditions

● MXG and MSN type

1/3

Work materials	Insert No.	Grades	Tool dia. (mm)									
			16/17					20/21				
			No. of teeth 2N					No. of teeth 3N				
			l (mm)	a_p (mm)	a_e (mm)	n (min ⁻¹)	V_f (mm/min)	l (mm)	a_p (mm)	a_e (mm)	n (min ⁻¹)	V_f (mm/min)
Carbon steel (C50, C55) Below 250HB	ENMU 100412 ZER-PH	JC8050 (JC7560)	~50	0.7	~10	3,580	8,590	~60	0.8	~14	2,860	10,300
			80	0.6	~10	3,580	8,590	100	0.6	~14	2,860	10,300
			120	0.6	~10	3,180	7,630	140	0.6	~14	2,550	9,180
Die steel (1.2344, 1.2379) Below 255HB	ENMU 100412 ZER-PH	JC8050 (JC7560)	~50	0.7	~10	3,580	8,590	~60	0.8	~14	2,860	10,300
			80	0.6	~10	3,580	8,590	100	0.6	~14	2,860	10,300
			120	0.6	~10	3,180	7,630	140	0.6	~14	2,550	9,180
Mold steel (1.2311, P20) 30~36HRC	ENMU 100412 ZER-PH	JC8050 (JC7560)	~50	0.7	~10	3,180	7,630	~60	0.8	~14	2,550	9,180
			80	0.6	~10	3,180	7,630	100	0.6	~14	2,550	9,180
			120	0.6	~10	2,590	6,220	140	0.6	~14	2,070	7,450
Mold Steel (1.2311, P21) 38~43HRC	ENMU 100412 ZER-PH	JC8118 (JC8050)	~50	0.6	~10	1,890	4,160	~60	0.6	~14	1,510	4,980
			80	0.5	~10	1,690	3,040	100	0.5	~14	1,350	3,650
			120	0.5	~10	1,590	2,860	140	0.5	~14	1,270	3,430
Hardened die steel (1.2344, 1.2379) 42~52HRC	ENMU100412 ZER-PH (ENMU100412 ZER-SL)	JC8118 (JC7518)	~50	0.6	~10	1,890	4,160	~60	0.6	~14	1,510	4,980
			80	0.5	~10	1,690	3,040	100	0.5	~14	1,350	3,650
			120	0.5	~10	1,590	2,860	140	0.5	~14	1,270	3,430
Hardened die steel (1.2344, 1.2379) 55~62HRC	ENMQ100312 ZER (ENMU100312 ZER-HL)	DH102	~50	0.2	~10	1,590	950	~60	0.2	~14	1,270	1,140
			80	0.15	~10	1,390	700	100	0.15	~14	1,110	830
			120	0.1	~10	1,290	650	140	0.1	~14	1,030	770
Cast iron (GG25) 160~260HB	ENMU 100412 ZER-PH	JC8118 (JC8050)	~50	0.7	~10	3,980	11,940	~60	1	~14	3,180	14,310
			80	0.7	~10	3,980	11,940	100	0.8	~14	3,180	14,310
			120	0.6	~10	3,580	8,590	140	0.6	~14	2,860	10,300
Nodular cast iron (GGG70) 170~300HB	ENMU 100412 ZER-PH	JC8118 (JC8050)	~50	0.7	~10	3,980	11,940	~60	1	~14	3,180	14,310
			80	0.7	~10	3,980	11,940	100	0.8	~14	3,180	14,310
			120	0.6	~10	3,580	8,590	140	0.6	~14	2,860	10,300
Austenitic stainless steel (AISI 304, 316, 317)	ENMU 100412 ZER-SL	JC7550 (JC7518)	~50	0.6	~10	2,390	4,780	~60	0.6	~14	1,910	5,730
			80	0.5	~10	2,390	4,780	100	0.5	~14	1,910	5,730
			120	0.5	~10	1,990	3,180	140	0.5	~14	1,590	3,820
Precipitation hardening stainless steel (SUS630)	ENMU100412 ZER-SL ENMU100412 ZER-PH	JC7550 (JC8050)	~50	0.5	~10	1,990	2,790	~60	0.5	~14	1,590	3,340
			80	0.4	~10	1,990	2,790	100	0.4	~14	1,590	3,340
			120	0.4	~10	1,790	2,150	140	0.4	~14	1,430	2,570
Super duplex stainless steel (S32750)	ENMU100412 ZER-SL ENMU100412 ZER-PH	JC7550 (JC8050)	~50	0.6	~10	1,990	1,190	~60	0.6	~14	1,590	1,430
			80	0.5	~10	1,990	1,190	100	0.5	~14	1,590	1,430
			120	0.5	~10	1,790	720	140	0.5	~14	1,430	860
Titanium alloy 35~43HRC	ENMU 100412 ZER-SL	JC7550 (JC7518)	~50	0.5	~10	1,190	1,670	~60	0.5	~14	950	2,000
			80	0.4	~10	1,190	1,670	100	0.4	~14	950	2,000
			120	0.4	~10	990	1,190	140	0.4	~14	800	1,440
Inconel 35~43HRC	ENMU 100412 ZER-SL	JC7518 (JC7550)	~50	0.5	~10	600	360	~60	0.5	~14	480	430
			80	0.3	~10	600	360	100	0.3	~14	480	430
			120	0.2	~10	600	360	140	0.2	~14	480	430

l : Overhung length a_p : Axial depth of cut a_e : Radial depth of cut n : Spindle speed V_f : Feed speed

Note:

*1. The figure to be adjusted according to the machine rigidity or work rigidity.

*2. In case of chatter occurring, recommend to reduce the depth of cut a_p or Spindle speed and keep feed per tooth.

*3. If machine does not have enough power, recommend to reduce the depth of cut a_p or Spindle speed and

Feed speed.

*4. Use air blow.

Recommended cutting conditions

MXG and MSN type

Work materials	Insert No.	Grades	Tool dia. (mm)									
			25					25/26				
			No. of teeth 3N					No. of teeth 4N				
			l (mm)	a_p (mm)	a_e (mm)	n (min ⁻¹)	V_f (mm/min)	l (mm)	a_p (mm)	a_e (mm)	n (min ⁻¹)	V_f (mm/min)
Carbon steel (C50, C55) Below 250HB	ENMU 100412 ZER-PH	JC8050 (JC7560)	~75	0.8	~19	2,290	8,240	~75	0.8	~19	2,290	10,990
			125	0.6	~19	2,290	8,240	125	0.6	~19	2,290	10,990
			175	0.6	~19	2,040	7,340	175	0.6	~19	2,040	9,790
Die steel (1.2344, 1.2379) Below 255HB	ENMU 100412 ZER-PH	JC8050 (JC7560)	~75	0.8	~19	2,290	8,240	~75	0.8	~19	2,290	10,990
			125	0.6	~19	2,290	8,240	125	0.6	~19	2,290	10,990
			175	0.6	~19	2,040	7,340	175	0.6	~19	2,040	9,790
Mold steel (1.2311, P20) 30~36HRC	ENMU 100412 ZER-PH	JC8050 (JC7560)	~75	0.8	~19	2,040	7,340	~75	0.8	~19	2,040	9,790
			125	0.6	~19	2,040	7,340	125	0.6	~19	2,040	9,790
			175	0.6	~19	1,660	5,980	175	0.6	~19	1,660	7,970
Mold Steel (1.2311, P21) 38~43HRC	ENMU 100412 ZER-PH	JC8118 (JC8050)	~75	0.6	~19	1,210	3,990	~75	0.6	~19	1,210	5,320
			125	0.5	~19	1,080	2,920	125	0.5	~19	1,080	3,890
			175	0.5	~19	1,020	2,750	175	0.5	~19	1,020	3,670
Hardened die steel (1.2344, 1.2379) 42~52HRC	ENMU100412 ZER-PH (ENMU100412 ZER-SL)	JC8118 (JC7518)	~75	0.6	~19	1,210	3,990	~75	0.6	~19	1,210	5,320
			125	0.5	~19	1,080	2,920	125	0.5	~19	1,080	3,890
			175	0.5	~19	1,020	2,750	175	0.5	~19	1,020	3,670
Hardened die steel (1.2344, 1.2379) 55~62HRC	ENMQ100312 ZER (ENMU100312 ZER-HL)	DH102	~75	0.2	~19	1,020	920	~75	0.2	~19	1,020	1,220
			125	0.15	~19	890	670	125	0.15	~19	890	890
			175	0.1	~19	830	620	175	0.1	~19	830	830
Cast iron (GG25) 160~260HB	ENMU 100412 ZER-PH	JC8118 (JC8050)	~75	1	~19	2,550	11,480	~75	1	~19	2,550	15,300
			125	0.8	~19	2,550	11,480	125	0.8	~19	2,550	15,300
			175	0.6	~19	2,290	8,240	175	0.6	~19	2,290	10,990
Nodular cast iron (GGG70) 170~300HB	ENMU 100412 ZER-PH	JC8118 (JC8050)	~75	1	~19	2,550	11,480	~75	1	~19	2,550	15,300
			125	0.8	~19	2,550	11,480	125	0.8	~19	2,550	15,300
			175	0.6	~19	2,290	8,240	175	0.6	~19	2,290	10,990
Austenitic stainless steel (AISI 304, 316, 317)	ENMU 100412 ZER-SL	JC7550 (JC7518)	~75	0.6	~19	1,530	4,590	~75	0.6	~19	1,530	6,120
			125	0.5	~19	1,530	4,590	125	0.5	~19	1,530	6,120
			175	0.5	~19	1,270	3,050	175	0.5	~19	1,270	4,060
Precipitation hardening stainless steel (SUS630)	ENMU100412 ZER-SL ENMU100412 ZER-PH	JC7550 (JC8050)	~75	0.5	~19	1,270	2,670	~75	0.5	~19	1,270	3,560
			125	0.4	~19	1,270	2,670	125	0.4	~19	1,270	3,560
			175	0.4	~19	1,150	2,070	175	0.4	~19	1,150	2,760
Super duplex stainless steel (S32750)	ENMU100412 ZER-SL ENMU100412 ZER-PH	JC7550 (JC8050)	~75	0.6	~19	1,270	1,140	~75	0.6	~19	1,270	1,520
			125	0.5	~19	1,270	1,140	125	0.5	~19	1,270	1,520
			175	0.5	~19	1,150	690	175	0.5	~19	1,150	920
Titanium alloy 35~43HRC	ENMU 100412 ZER-SL	JC7550 (JC7518)	~75	0.5	~19	760	1,600	~75	0.5	~19	760	2,130
			125	0.4	~19	760	1,600	125	0.4	~19	760	2,130
			175	0.4	~19	640	1,150	175	0.4	~19	640	1,540
Inconel 35~43HRC	ENMU 100412 ZER-SL	JC7518 (JC7550)	~75	0.5	~19	380	340	~75	0.5	~19	380	460
			125	0.3	~19	380	340	125	0.3	~19	380	460
			175	0.2	~19	380	340	175	0.2	~19	380	460

l : Overhung length a_p : Axial depth of cut a_e : Radial depth of cut n : Spindle speed V_f : Feed speed

Note:

- *1. The figure to be adjusted according to the machine rigidity or work rigidity.
- *2. In case of chatter occurring, recommend to reduce the depth of cut ap or Spindle speed and keep feed per tooth.
- *3. If machine does not have enough power, recommend to reduce the depth of cut ap or Spindle speed and Feed speed.
- *4. Use air blow.

Work materials	Insert No.	Grades	Tool dia. (mm)									
			30/32/35					40/42				
			No. of teeth 5N					No. of teeth 6N				
			l (mm)	a_p (mm)	a_e (mm)	n (min^{-1})	V_f (mm/min)	l (mm)	a_p (mm)	a_e (mm)	n (min^{-1})	V_f (mm/min)
Carbon steel (C50, C55) Below 250HB	ENMU 100412 ZER-PH	JC8050 (JC7560)	~90	0.8	~25	1,910	11,460	~120	0.8	~32	1,430	10,300
			150	0.6	~25	1,910	11,460	200	0.6	~32	1,430	10,300
			210	0.6	~25	1,700	10,200	280	0.6	~32	1,270	9,140
Die steel (1.2344, 1.2379) Below 255HB	ENMU 100412 ZER-PH	JC8050 (JC7560)	~90	0.8	~25	1,910	11,460	~120	0.8	~32	1,430	10,300
			150	0.6	~25	1,910	11,460	200	0.6	~32	1,430	10,300
			210	0.6	~25	1,700	10,200	280	0.6	~32	1,270	9,140
Mold steel (1.2311, P20) 30~36HRC	ENMU 100412 ZER-PH	JC8050 (JC7560)	~90	0.8	~25	1,700	10,200	~120	0.8	~32	1,270	9,140
			150	0.6	~25	1,700	10,200	200	0.6	~32	1,270	9,140
			210	0.6	~25	1,380	8,280	280	0.6	~32	1,030	7,420
Mold Steel (1.2311, P21) 38~43HRC	ENMU 100412 ZER-PH	JC8118 (JC8050)	~90	0.6	~25	1,010	5,560	~120	0.6	~32	760	5,020
			150	0.5	~25	900	4,050	200	0.5	~32	680	3,670
			210	0.5	~25	850	3,830	280	0.5	~32	640	3,460
Hardened die steel (1.2344, 1.2379) 42~52HRC	ENMU100412 ZER-PH (ENMU100412 ZER-SL)	JC8118 (JC7518)	~90	0.6	~25	1,010	5,560	~120	0.6	~32	760	5,020
			150	0.5	~25	900	4,050	200	0.5	~32	680	3,670
			210	0.5	~25	850	3,830	280	0.5	~32	640	3,460
Hardened die steel (1.2344, 1.2379) 55~62HRC	ENMQ100312 ZER (ENMU100312 ZER-HL)	DH102	~90	0.2	~25	850	1,280	~120	0.2	~32	640	1,150
			150	0.15	~25	740	930	200	0.15	~32	560	840
			210	0.1	~25	690	860	280	0.1	~32	520	780
Cast iron (GG25) 160~260HB	ENMU 100412 ZER-PH	JC8118 (JC8050)	~90	1	~25	2,120	15,900	~120	1	~32	1,590	14,310
			150	0.8	~25	2,120	15,900	200	0.8	~32	1,590	14,310
			210	0.6	~25	1,910	11,460	280	0.6	~32	1,430	10,300
Nodular cast iron (GGG70) 170~300HB	ENMU 100412 ZER-PH	JC8118 (JC8050)	~90	1	~25	2,120	15,900	~120	1	~32	1,590	14,310
			150	0.8	~25	2,120	15,900	200	0.8	~32	1,590	14,310
			210	0.6	~25	1,910	11,460	280	0.6	~32	1,430	10,300
Austenitic stainless steel (AISI 304, 316, 317)	ENMU 100412 ZER-SL	JC7550 (JC7518)	~90	0.6	~25	1,270	6,350	~120	0.6	~32	950	5,700
			150	0.5	~25	1,270	6,350	200	0.5	~32	950	5,700
			210	0.5	~25	1,060	4,240	280	0.5	~32	800	3,840
Precipitation hardening stainless steel (SUS630)	ENMU100412 ZER-SL ENMU100412 ZER-PH	JC7550 (JC8050)	~90	0.5	~25	1,060	3,710	~120	0.5	~32	800	3,360
			150	0.4	~25	1,060	3,710	200	0.4	~32	800	3,360
			210	0.4	~25	950	2,850	280	0.4	~32	720	2,590
Super duplex stainless steel (S32750)	ENMU100412 ZER-SL ENMU100412 ZER-PH	JC7550 (JC8050)	~90	0.6	~25	1,060	1,590	~120	0.6	~32	800	1,440
			150	0.5	~25	1,060	1,590	200	0.5	~32	800	1,440
			210	0.5	~25	950	950	280	0.5	~32	720	860
Titanium alloy 35~43HRC	ENMU 100412 ZER-SL	JC7550 (JC7518)	~90	0.5	~25	640	2,240	~120	0.5	~32	480	2,020
			150	0.4	~25	640	2,240	200	0.4	~32	480	2,020
			210	0.4	~25	530	1,590	280	0.4	~32	400	1,440
Inconel 35~43HRC	ENMU 100412 ZER-SL	JC7518 (JC7550)	~90	0.5	~25	320	480	~120	0.5	~32	240	430
			150	0.3	~25	320	480	200	0.3	~32	240	430
			210	0.2	~25	320	480	280	0.2	~32	240	430

l : Overhung length a_p : Axial depth of cut a_e : Radial depth of cut n : Spindle speed V_f : Feed speed

Note:

*1. The figure to be adjusted according to the machine rigidity or work rigidity.

*2. In case of chatter occurring, recommend to reduce the depth of cut a_p or Spindle speed and keep feed per tooth.

*3. If machine does not have enough power, recommend to reduce the depth of cut a_p or Spindle speed and

Feed speed.

*4. Use air blow.

Recommended cutting conditions

Shank type

1/2

Work materials	Insert No.	Grades	Tool dia. (mm)									
			16				20					
			No. of teeth 2N				No. of teeth 3N					
			l (mm)	a_p (mm)	a_e (mm)	n (min ⁻¹)	V_f (mm/min)	l (mm)	a_p (mm)	a_e (mm)	n (min ⁻¹)	V_f (mm/min)
Carbon steel (C50, C55) Below 250HB	ENMU 100412 ZER-PH	JC8050 (JC7560)	~30	0.7	~10	3,580	8,590					
			30~50	0.6	~10	3,580	8,590	~60	0.6	~14	2,860	10,300
			50~70	0.6	~10	3,180	7,630	60~100	0.6	~14	2,550	9,180
Die steel (1.2344, 1.2379) Below 255HB	ENMU 100412 ZER-PH	JC8050 (JC7560)	~30	0.7	~10	3,580	8,590					
			30~50	0.6	~10	3,580	8,590	~60	0.6	~14	2,860	10,300
			50~70	0.6	~10	3,180	7,630	60~100	0.6	~14	2,550	9,180
Mold steel (1.2311, P20) 30~36HRC	ENMU 100412 ZER-PH	JC8050 (JC7560)	~30	0.7	~10	3,180	7,630					
			30~50	0.6	~10	3,180	7,630	~60	0.6	~14	2,550	9,180
			50~70	0.6	~10	2,590	6,220	60~100	0.6	~14	2,070	7,450
Mold Steel (1.2311, P21) 38~43HRC	ENMU 100412 ZER-PH	JC8118 (JC8050)	~30	0.6	~10	1,890	4,160					
			30~50	0.5	~10	1,690	3,040	~60	0.5	~14	1,350	3,650
			50~70	0.5	~10	1,590	2,860	60~100	0.5	~14	1,270	3,430
Hardened die steel (1.2344, 1.2379) 42~52HRC	ENMU100412 ZER-PH (ENMU100412 ZER-SL)	JC8118 (JC7518)	~30	0.6	~10	1,890	4,160					
			30~50	0.5	~10	1,690	3,040	~60	0.5	~14	1,350	3,650
			50~70	0.5	~10	1,590	2,860	60~100	0.5	~14	1,270	3,430
Hardened die steel (1.2344, 1.2379) 55~62HRC	ENMQ100312 ZER (ENMU100312 ZER-HL)	DH102	~30	0.2	~10	1,590	950					
			30~50	0.15	~10	1,390	700	~60	0.15	~14	1,110	830
			50~70	0.1	~10	1,290	650	60~100	0.1	~14	1,030	770
Cast iron (GG25) 160~260HB	ENMU 100412 ZER-PH	JC8118 (JC8050)	~30	0.7	~10	3,980	11,940					
			30~50	0.7	~10	3,980	11,940	~60	0.8	~14	3,180	14,310
			50~70	0.6	~10	3,580	8,590	60~100	0.6	~14	2,860	10,300
Nodular cast iron (GGG70) 170~300HB	ENMU 100412 ZER-PH	JC8118 (JC8050)	~30	0.7	~10	3,980	11,940					
			30~50	0.7	~10	3,980	11,940	~60	0.8	~14	3,180	14,310
			50~70	0.6	~10	3,580	8,590	60~100	0.6	~14	2,860	10,300
Austenitic stainless steel (AISI 304, 316, 317)	ENMU 100412 ZER-SL	JC7550 (JC7518)	~30	0.6	~10	2,390	4,780					
			30~50	0.5	~10	2,390	4,780	~60	0.5	~14	1,910	5,730
			50~70	0.5	~10	1,990	3,180	60~100	0.5	~14	1,590	3,820
Precipitation hardening stainless steel (SUS630)	ENMU100412 ZER-SL ENMU100412 ZER-PH	JC7550 (JC8050)	~30	0.5	~10	1,990	2,790					
			30~50	0.4	~10	1,990	2,790	~60	0.4	~14	1,590	3,340
			50~70	0.4	~10	1,790	2,150	60~100	0.4	~14	1,430	2,570
Super duplex stainless steel (S32750)	ENMU100412 ZER-SL ENMU100412 ZER-PH	JC7550 (JC8050)	~30	0.6	~10	1,990	1,190					
			30~50	0.5	~10	1,990	1,190	~60	0.5	~14	1,590	1,430
			50~70	0.5	~10	1,790	720	60~100	0.5	~14	1,430	860
Titanium alloy 35~43HRC	ENMU 100412 ZER-SL	JC7550 (JC7518)	~30	0.5	~10	1,190	1,670					
			30~50	0.4	~10	1,190	1,670	~60	0.4	~14	950	2,000
			50~70	0.4	~10	990	1,190	60~100	0.4	~14	800	1,440
Inconel 35~43HRC	ENMU 100412 ZER-SL	JC7518 (JC7550)	~30	0.5	~10	600	360					
			30~50	0.3	~10	600	360	~60	0.3	~14	480	430
			50~70	0.2	~10	600	360	60~100	0.2	~14	480	430

l : Overhang length a_p : Axial depth of cut a_e : Radial depth of cut n : Spindle speed V_f : Feed speed

Note:

*1. The figure to be adjusted according to the machine rigidity or work rigidity.

*2. In case of chatter occurring, recommend to reduce the depth of cut a_p or Spindle speed and keep feed per tooth.

*3. If machine does not have enough power, recommend to reduce the depth of cut a_p or Spindle speed and

Feed speed.

*4. Use air blow.

Shank type

2/2

Work materials	Insert No.	Grades	Tool dia. (mm)									
			25					32				
			No. of teeth 4N					No. of teeth 5N				
			l (mm)	a_p (mm)	a_e (mm)	n (min ⁻¹)	V_f (mm/min)	l (mm)	a_p (mm)	a_e (mm)	n (min ⁻¹)	V_f (mm/min)
Carbon steel (C50, C55) Below 250HB	ENMU 100412 ZER-PH	JC8050 (JC7560)	~70	0.6	~19	2,290	10,990	~90	0.6	~25	1,790	10,740
			70~120	0.6	~19	2,040	9,790	90~140	0.6	~25	1,590	9,540
Die steel (1.2344, 1.2379) Below 255HB	ENMU 100412 ZER-PH	JC8050 (JC7560)	~70	0.6	~19	2,290	10,990	~90	0.6	~25	1,790	10,740
			70~120	0.6	~19	2,040	9,790	90~140	0.6	~25	1,590	9,540
Mold steel (1.2311, P20) 30~36HRC	ENMU 100412 ZER-PH	JC8050 (JC7560)	~70	0.6	~19	2,040	9,790	~90	0.6	~25	1,590	9,540
			70~120	0.6	~19	1,660	7,970	90~140	0.6	~25	1,290	7,740
Mold Steel (1.2311, P21) 38~43HRC	ENMU 100412 ZER-PH	JC8118 (JC8050)	~70	0.5	~19	1,080	3,890	~90	0.5	~25	850	3,830
			70~120	0.5	~19	1,020	3,670	90~140	0.5	~25	800	3,600
Hardened die steel (1.2344, 1.2379) 42~52HRC	ENMU100412 ZER-PH (ENMU100412 ZER-SL)	JC8118 (JC7518)	~70	0.5	~19	1,080	3,890	~90	0.5	~25	850	3,830
			70~120	0.5	~19	1,020	3,670	90~140	0.5	~25	800	3,600
Hardened die steel (1.2344, 1.2379) 55~62HRC	ENMQ100312 ZER (ENMU100312 ZER-HL)	DH102	~70	0.15	~19	890	890	~90	0.15	~25	700	880
			70~120	0.1	~19	830	830	90~140	0.1	~25	650	810
Cast iron (GG25) 160~260HB	ENMU 100412 ZER-PH	JC8118 (JC8050)	~70	0.8	~19	2,550	15,300	~90	0.8	~25	1,990	14,930
			70~120	0.6	~19	2,290	10,990	90~140	0.6	~25	1,790	10,740
Nodular cast iron (GGG70) 170~300HB	ENMU 100412 ZER-PH	JC8118 (JC8050)	~70	0.8	~19	2,550	15,300	~90	0.8	~25	1,990	14,930
			70~120	0.6	~19	2,290	10,990	90~140	0.6	~25	1,790	10,740
Austenitic stainless steel (AISI 304, 316, 317)	ENMU 100412 ZER-SL	JC7550 (JC7518)	~70	0.5	~19	1,530	6,120	~90	0.5	~25	1,190	5,950
			70~120	0.5	~19	1,270	4,060	90~140	0.5	~25	990	3,960
Precipitation hardening stainless steel (SUS630)	ENMU100412 ZER-SL ENMU100412 ZER-PH	JC7550 (JC8050)	~70	0.4	~19	1,270	3,560	~90	0.4	~25	990	3,470
			70~120	0.4	~19	1,150	2,760	90~140	0.4	~25	900	2,700
Super duplex stainless steel (S32750)	ENMU100412 ZER-SL ENMU100412 ZER-PH	JC7550 (JC8050)	~70	0.5	~19	1,270	1,520	~90	0.5	~25	990	1,490
			70~120	0.5	~19	1,150	920	90~140	0.5	~25	900	900
Titanium alloy 35~43HRC	ENMU 100412 ZER-SL	JC7550 (JC7518)	~70	0.4	~19	760	2,130	~90	0.4	~25	600	2,100
			70~120	0.4	~19	640	1,540	90~140	0.4	~25	500	1,500
Inconel 35~43HRC	ENMU 100412 ZER-SL	JC7518 (JC7550)	~70	0.3	~19	380	460	~90	0.3	~25	300	450
			70~120	0.2	~19	380	460	90~140	0.2	~25	300	450

l : Overhung length a_p : Axial depth of cut a_e : Radial depth of cut n : Spindle speed V_f : Feed speed

Note:

*1. The figure to be adjusted according to the machine rigidity or work rigidity.

*2. In case of chatter occurring, recommend to reduce the depth of cut a_p or Spindle speed and keep feed per tooth.

*3. If machine does not have enough power, recommend to reduce the depth of cut a_p or Spindle speed and

Feed speed.

*4. Use air blow.

Recommended cutting conditions

Facemill type

1/2

Work materials	Insert No.	Grades	Tool dia. (mm)									
			50/52					63/66				
			No. of teeth 7N									
			l (mm)	a_p (mm)	a_e (mm)	n (min ⁻¹)	V_f (mm/min)	l (mm)	a_p (mm)	a_e (mm)	n (min ⁻¹)	V_f (mm/min)
Carbon steel (C50, C55) Below 250HB	ENMU 100412 ZER-PH	JC8050 (JC7560)	~150	1	~40	1,020	8,570	~150	1	~50	810	6,800
			200	0.8	~40	1,020	8,570	200	0.8	~50	810	6,800
			250	0.6	~40	890	7,480	250	0.6	~50	710	5,960
			300	0.5	~40	830	6,970	300	0.5	~50	660	5,540
			350	0.4	~40	830	6,970	350	0.4	~50	660	5,540
Die steel (1.2344, 1.2379) Below 255HB	ENMU 100412 ZER-PH	JC8050 (JC7560)	~150	1	~40	1,020	8,570	~150	1	~50	810	6,800
			200	0.8	~40	1,020	8,570	200	0.8	~50	810	6,800
			250	0.6	~40	890	7,480	250	0.6	~50	710	5,960
			300	0.5	~40	830	6,970	300	0.5	~50	660	5,540
			350	0.4	~40	830	6,970	350	0.4	~50	660	5,540
Mold steel (1.2311, P20) 30~36HRC	ENMU 100412 ZER-PH	JC8050 (JC7560)	~150	1	~40	1,020	8,570	~150	1	~50	810	6,800
			200	0.8	~40	1,020	8,570	200	0.8	~50	810	6,800
			250	0.6	~40	890	7,480	250	0.6	~50	710	5,960
			300	0.5	~40	830	6,970	300	0.5	~50	660	5,540
			350	0.4	~40	830	6,970	350	0.4	~50	660	5,540
Mold Steel (1.2311, P21) 38~43HRC	ENMU 100412 ZER-PH	JC8118 (JC8050)	~150	0.8	~40	540	4,160	~150	0.8	~50	430	3,310
			200	0.6	~40	540	4,160	200	0.6	~50	430	3,310
			250	0.4	~40	510	3,210	250	0.4	~50	400	2,520
			300	0.3	~40	480	3,020	300	0.3	~50	380	2,390
			350	0.3	~40	480	2,690	350	0.3	~50	380	2,130
Hardened die steel (1.2344, 1.2379) 42~52HRC	ENMU100412 ZER-PH (ENMU100412 ZER-SL)	JC8118 (JC7518)	~150	0.6	~40	540	4,160	~150	0.6	~50	430	3,310
			200	0.4	~40	540	4,160	200	0.4	~50	430	3,310
			250	0.2	~40	510	3,210	250	0.2	~50	400	2,520
			300	0.1	~40	510	3,210	300	0.1	~50	400	2,520
			350	—	—	—	—	350	—	—	—	—
Hardened die steel (1.2344, 1.2379) 55~62HRC	ENMQ100312 ZER (ENMU100312 ZER-HL)	DH102	~150	0.2	~40	510	1,070	~150	0.2	~50	400	840
			200	0.15	~40	450	790	200	0.15	~50	350	610
			250	0.1	~40	410	720	250	0.1	~50	330	580
			300	—	—	—	—	300	—	—	—	—
			350	—	—	—	—	350	—	—	—	—
Cast iron (GG25) 160~260HB	ENMU 100412 ZER-PH	JC8118 (JC8050)	~150	1	~40	1,150	12,080	~150	1	~50	910	9,560
			200	0.8	~40	1,150	12,080	200	0.8	~50	910	9,560
			250	0.6	~40	1,020	10,710	250	0.6	~50	810	8,510
			300	0.5	~40	950	9,980	300	0.5	~50	760	7,980
			350	0.4	~40	950	7,980	350	0.4	~50	760	6,380
Nodular cast iron (GGG70) 170~300HB	ENMU 100412 ZER-PH	JC8118 (JC8050)	~150	1	~40	1,150	12,080	~150	1	~50	910	9,560
			200	0.8	~40	1,150	12,080	200	0.8	~50	910	9,560
			250	0.6	~40	1,020	10,710	250	0.6	~50	810	8,510
			300	0.5	~40	950	9,980	300	0.5	~50	760	7,980
			350	0.4	~40	950	7,980	350	0.4	~50	760	6,380

l : Overhung length a_p : Axial depth of cut a_e : Radial depth of cut n : Spindle speed V_f : Feed speed

Note:

*1. The figure to be adjusted according to the machine rigidity or work rigidity.

*2. In case of chatter occurring, recommend to reduce the depth of cut a_p or Spindle speed and keep feed per tooth.

*3. If machine does not have enough power, recommend to reduce the depth of cut a_p or Spindle speed and Feed speed.

*4. Use air blow.

Facemill type

2/2

Work materials	Insert No.	Grades	Tool dia. (mm)									
			50/52					63/66				
			No. of teeth 7N					No. of teeth 7N				
			l (mm)	a_p (mm)	a_e (mm)	n (min^{-1})	V_f (mm/min)	l (mm)	a_p (mm)	a_e (mm)	n (min^{-1})	V_f (mm/min)
Austenitic stainless steel (AISI 304, 316, 317)	ENMU 100412 ZER-SL	JC7550 (JC7518)	~150	0.8	~40	760	5,320	~150	0.8	~50	610	4,270
			200	0.6	~40	760	5,320	200	0.6	~50	610	4,270
			250	0.4	~40	640	4,480	250	0.4	~50	510	3,570
			300	0.3	~40	640	4,480	300	0.3	~50	510	3,570
			350	0.3	~40	640	3,580	350	0.3	~50	510	2,860
Precipitation hardening stainless steel (SUS630)	ENMU100412 ZER-SL ENMU100412 ZER-PH	JC7550 (JC8050)	~150	0.6	~40	640	3,140	~150	0.6	~50	510	2,500
			200	0.5	~40	640	3,140	200	0.5	~50	510	2,500
			250	0.3	~40	570	2,790	250	0.3	~50	450	2,210
			300	0.2	~40	570	2,790	300	0.2	~50	450	2,210
			350	0.2	~40	570	2,390	350	0.2	~50	450	1,890
Super duplex stainless steel (S32750)	ENMU100412 ZER-SL ENMU100412 ZER-PH	JC7550 (JC8050)	~150	0.8	~40	640	1,340	~150	0.8	~50	510	1,070
			200	0.6	~40	640	1,340	200	0.6	~50	510	1,070
			250	0.4	~40	570	1,200	250	0.4	~50	450	950
			300	0.3	~40	570	1,200	300	0.3	~50	450	950
			350	0.3	~40	570	800	350	0.3	~50	450	630
Titanium alloy 35~43HRC	ENMU 100412 ZER-SL	JC7550 (JC7518)	~150	0.7	~40	380	1,860	~150	0.7	~50	300	1,470
			200	0.5	~40	380	1,860	200	0.5	~50	300	1,470
			250	0.3	~40	320	1,570	250	0.3	~50	250	1,230
			300	0.3	~40	320	1,570	300	0.3	~50	250	1,230
			350	0.3	~40	320	1,340	350	0.3	~50	250	1,050
Inconel 35~43HRC	ENMU 100412 ZER-SL	JC7518 (JC7550)	~150	0.7	~40	190	400	~150	0.7	~50	150	320
			200	0.5	~40	190	400	200	0.5	~50	150	320
			250	0.3	~40	160	340	250	0.3	~50	130	270
			300	0.2	~40	160	340	300	0.2	~50	130	270
			350	0.2	~40	130	270	350	0.2	~50	100	210

l : Overhung length a_p : Axial depth of cut a_e : Radial depth of cut n : Spindle speed V_f : Feed speed

Note:

*1. The figure to be adjusted according to the machine rigidity or work rigidity.

*2. In case of chatter occurring, recommend to reduce the depth of cut a_p or Spindle speed and keep feed per tooth.

*3. If machine does not have enough power, recommend to reduce the depth of cut a_p or Spindle speed and Feed speed.

*4. Use air blow.



HEADQUARTER

DIJET Industrial Co.Ltd.

1-1-18, Kami-Higashi,

Hirano-ku, Osaka 547-0002, Japan

PHONE +81-6-6791-6781

FAX +81-6-6793-1221

MAIN OFFICE EUROPE

DIJET GmbH

Immermannstraße 9

40210 Düsseldorf, Germany

PHONE +49-211-5008820

FAX +49-211-5008823

www.dijet.de



ZIBTRPRO

tehnologija obdelave · vpenjalni sistemi